

**METRIC**  
ALL DIMENSIONS IN MILLIMETRES

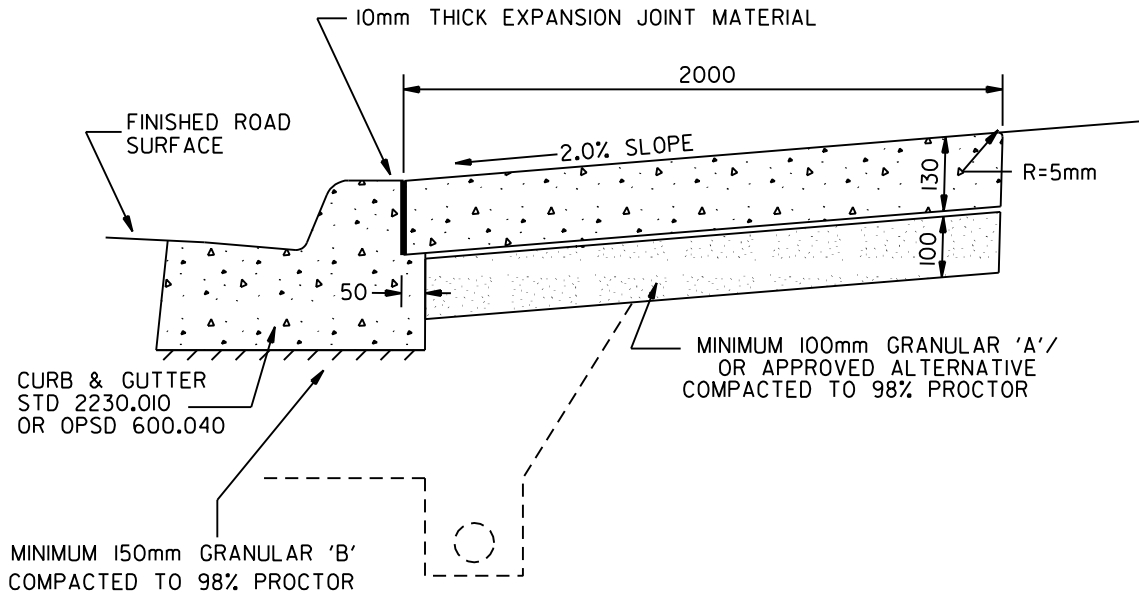

**NOTES:**

1. AT COMMERCIAL AND INDUSTRIAL DRIVEWAYS USE WIRE MESH.
2. AT ALL DRIVEWAYS, SIDEWALK SHALL BE 180mm THICK AND THE SIDEWALK SLOPE SHALL BE ADJUSTED TO FIT THE CURB AT THE DRIVEWAY DEPRESSION.
3. CONCRETE TO BE AS PER OPSS I350
4. BEDDING TO BE SPECIFIED.
5. THIS STANDARD TO BE READ IN CONJUNCTION WITH STD. 2240.010
6. AGGREGATE MATERIALS CONTAINING RECLAIMED PORTLAND CEMENT AND/OR RECLAIMED ASPHALT PAVEMENT MAY ONLY BE USED IN NON-LOAD BEARING AREAS. THE FINAL BLEND SHALL NOT CONTAIN MORE THAN 30% PERCENT BY MASS OF ASPHALT COATED PARTICLES AS DETERMINED BY PERCENTAGE OF ASPHALT COATED PARTICLES, LS621.

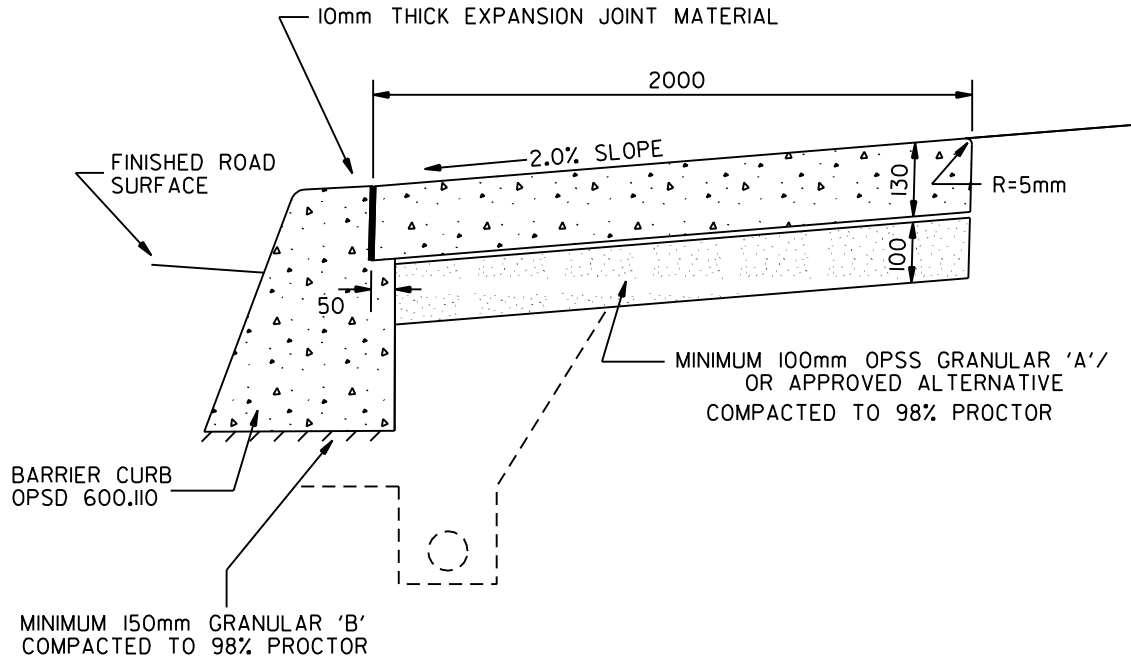

**STANDARD  
CONCRETE SIDEWALK  
ABUTTING CURB  
OR CURB AND GUTTER**

EFF. DATE	2002-01-01	SCALE	N.T.S.
REV.	3	STANDARD No.	2240.040