

METRIC

ALL DIMENSIONS IN MILLIMETRES

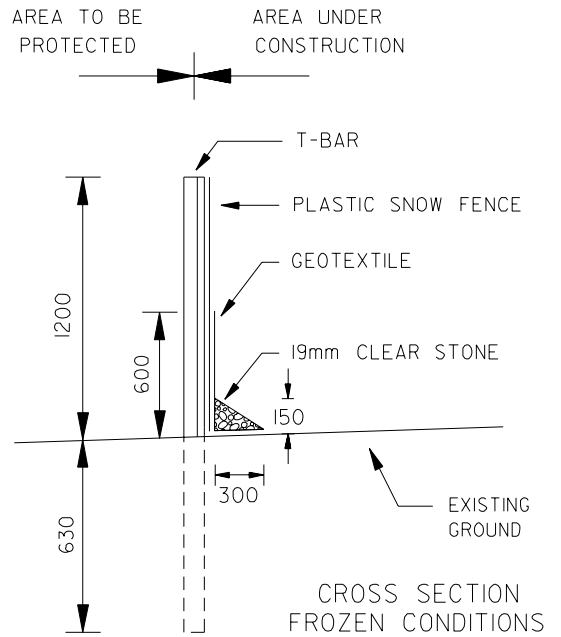
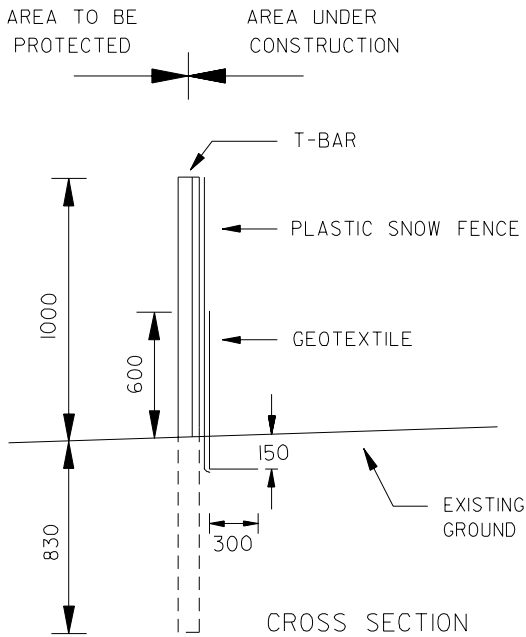
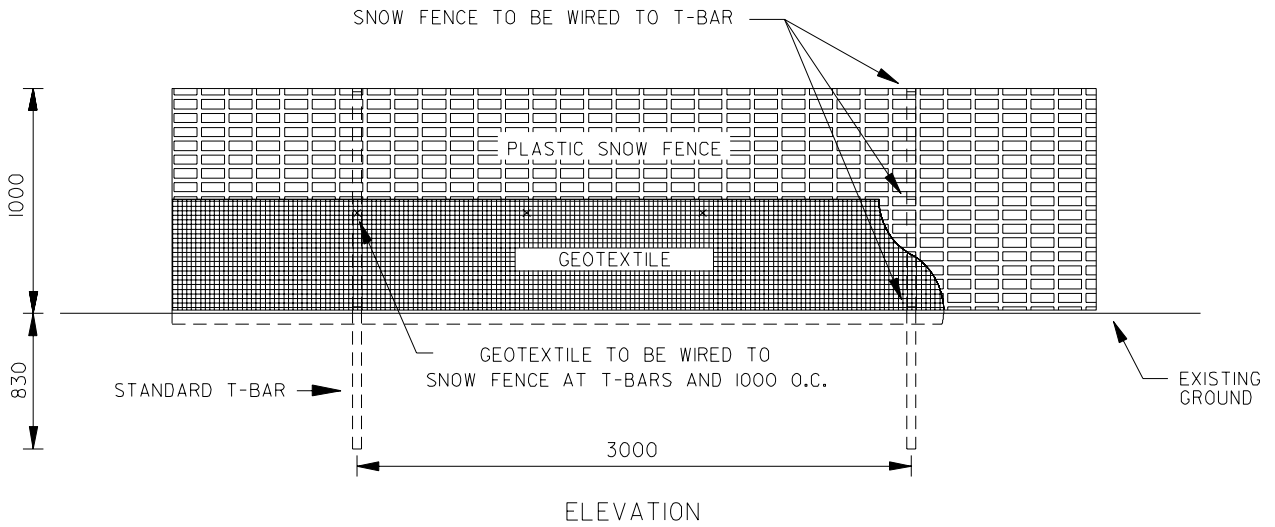

NOTES:

1. NON WOVEN OR WOVEN GEOTEXTILE (MAYBE CONSIDERED BASED ON SOIL PARAMETERS AND SITE CONDITION) TO HAVE A MINIMUM EQUIVALENT OPENING SIZE OF 0.15mm AND A MAXIMUM EQUIVALENT OPENING SIZE OF 0.25mm.
2. GEOTEXTILE TO HAVE A HORIZONTAL OVERLAP OF 1000mm AT JOINTS.
3. SNOW FENCE TO BE UV STABILIZED HIGH DENSITY POLYETHYLENE OR APPROVED EQUIVALENT.



STANDARD

SEDIMENT CONTROL FENCE

EFF. DATE	2002-01-01	SCALE	N.T.S.
REV.		STANDARD No.	2940.010