

*Reproduction, adaptation, or translation of this manual is prohibited without  
prior written consent of Laser Atlanta LLC*

# SpeedLaser<sup>®</sup>

---

## USER'S GUIDE

---



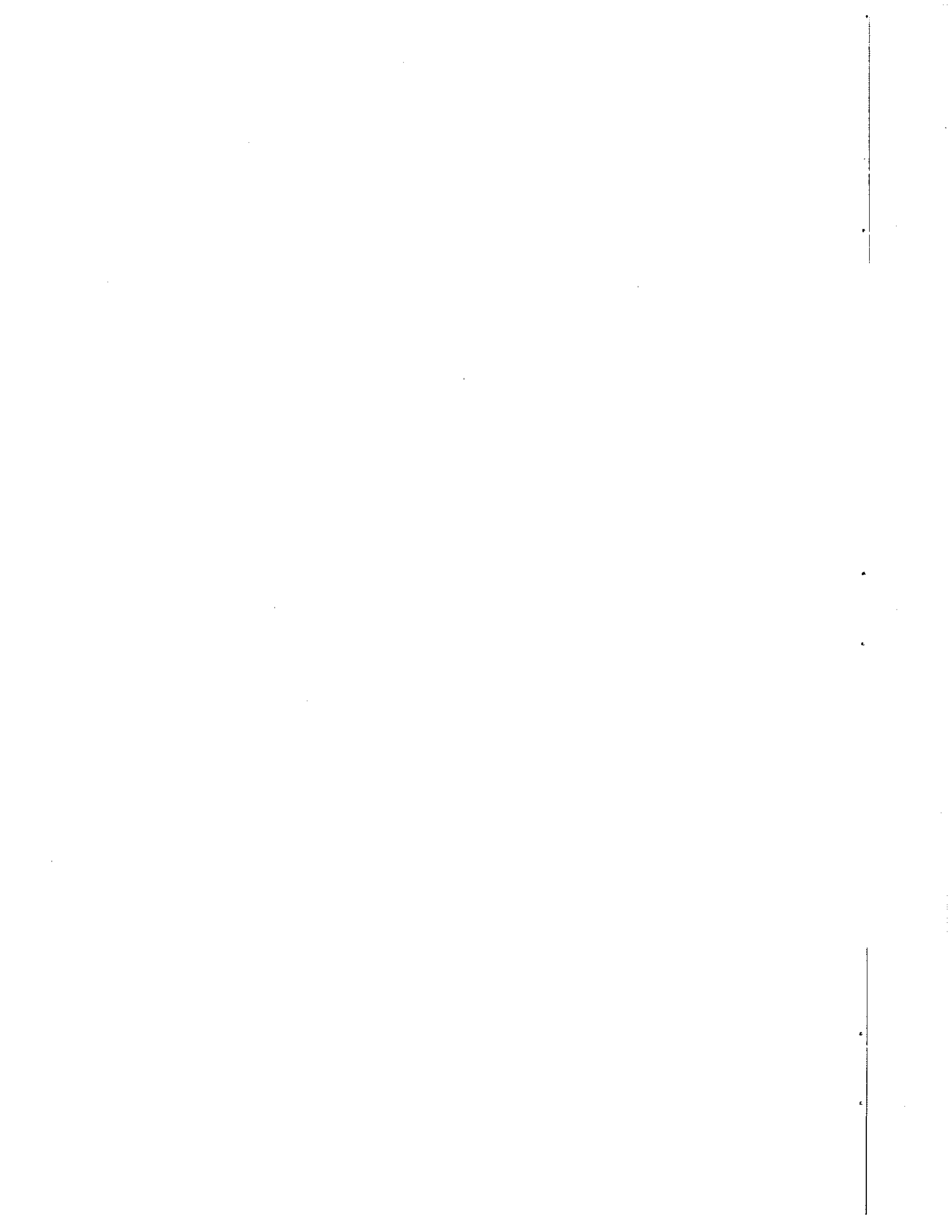



## USER'S MANUAL

---

PLEASE SEE BACK COVER FOR CONTACT  
INFORMATION REGARDING REPAIRS AND  
SALES

P/N 40150-W1  
(For Version 4.66 and above)

The information contained here is accurate and reliable to the best of our knowledge at time of printing and is subject to change without notice. No responsibility is assumed by Laser Atlanta for use of this information. Laser Atlanta, its logo and SpeedLaser are trademarks of Laser Atlanta LLC. All other trademarks are the property of their respective companies.  
© 2007 Laser Atlanta LLC. All rights reserved.

# SpeedLaser<sup>®</sup> "S" and "R"

Use these same instructions

"S"

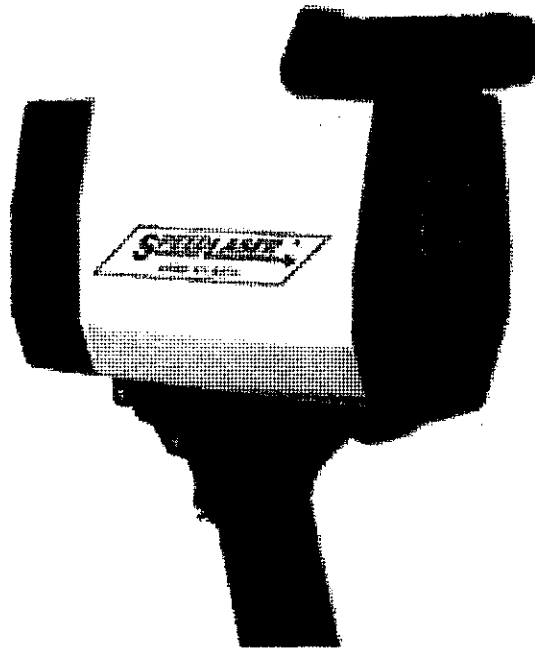

"R"

# TABLE OF CONTENTS

<b>1</b>	<b>INTRODUCTION.....</b>	<b>6</b>
	Cautions.....	7
	Capabilities .....	8
<b>2</b>	<b>GETTING STARTED.....</b>	<b>10</b>
	Packing List .....	10
	SpeedLaser® Controls & Layout .....	11
	Battery Handle Power.....	13
	Connecting a Handle .....	14
	To Power ON.....	15
	To Power OFF.....	15
<b>3</b>	<b>SPEED MEASUREMENT.....</b>	<b>16</b>
	Measuring Speed .....	16
	Approaching and Receding Targets:.....	17
	Manufacturer's Recommended Daily Test.....	18
<b>4</b>	<b>USER SETTINGS.....</b>	<b>22</b>
	Intensity and Contrast .....	22
	LCD Backlight:.....	22
	LCD Contrast:.....	22
	HUD Brightness:.....	22
	The MENU System .....	23
	Main Menu.....	26
	Test Mode .....	27
	Audio .....	28
	HUD Mode .....	29
	AIMING MENU.....	30
	Obstructed Mode.....	32
<b>5</b>	<b>APPENDICES .....</b>	<b>33</b>

<b>APPENDICES:</b>	<b>PAGE #</b>
<b>A: Troubleshooting / Error Messages</b>	<b>33</b>
<b>B: Care and Maintenance</b>	<b>34</b>
<b>C: SpeedLaser® and Accessory Diagrams</b>	<b>36</b>
<b>D: Measuring Surface Datum</b>	<b>37</b>
<b>E: LIDAR Menu Tree</b>	<b>39</b>
<b>Warranty</b>	<b>38</b>

## CHAPTER 1 Introduction

Thank you for purchasing the SpeedLaser®. This rugged laser speed detection device integrates the latest in solid-state laser technologies to bring you hand-held, eye-safe laser speed and distance measurement.

The SpeedLaser® is a Class 1 eye safe, multi-function device generally used to calculate range and speed of targets at a distance. Depending on reflective characteristics of the targets, the environment and other factors, distance may vary.

The technology utilized by the SpeedLaser® is called LIDAR: LIght Detection And Ranging. Your SpeedLaser® measures the time it takes a pulse of laser light to travel from the LIDAR to the target vehicle and back (pulsed time-of-flight). This round trip time is converted to a distance ( $d=ct/2$ ). The distance to the target vehicle is calculated in this manner over two hundred times per second. Sophisticated computer algorithms combine these individual range calculations to compute the extremely accurate speed displayed. The IACP lists this device on their product list (CPL) after testing to their specifications.

To get the most from your new SpeedLaser®, please take the time to read through this manual. For your convenience and ease of understanding, it has been divided into 5 sections:

Chapter 1:	Introduction
Chapter 2:	Getting Started
Chapter 3:	Speed Measurement
Chapter 4:	User Setting's
Appendices:	Information on care, troubleshooting, and specifications

If you have questions or comments, please do not hesitate to contact us.

**PLEASE SEE BACK COVER FOR CONTACT  
INFORMATION REGARDING REPAIRS AND SALES**

## **Cautions:**

Every step has been taken to ensure your SpeedLaser® is completely safe to use. However, certain common-sense precautions should always be taken when using your SpeedLaser®.

- Do not open the LIDAR unit's housing under any circumstances.
- Do not point the SpeedLaser® directly at the sun.
- Use only Laser Atlanta approved power sources and accessories. (use of unauthorized accessories may void the warranty)
- Do not store SpeedLaser® in areas of high humidity.
- Do not place SpeedLaser® on unstable surfaces.
- Always transport the SpeedLaser® in its carrying case.

Your SpeedLaser® is a Class 1 Laser Product that complies with 21 CFR 1040.10 and 1040.11. Class 1 is the lowest classification of laser products, with regards to risk while in use. This class of lasers cannot emit levels of optical radiation above the exposure limits for the eye under any exposure conditions inherent to the laser product.

**Caution: The use of optical instruments with this product will increase eye hazard. Do not point this laser at anyone with optical viewing devices within 50 feet/15 meters of the operator.**

Although optical viewing instruments may increase eye hazard, it is unlikely that actual damage can occur. Prescription eyeglasses, contact lenses, and sunglasses are not considered optical gain devices since they merely correct the focus of the human eye to normal.

Optical devices that provide magnification may increase the risk of eye-hazard. These include binoculars, telescopes and magnifying glasses.

Certain municipalities and countries require settings to differing measurements (mph or km/h). Your unit is factory set to the appropriate unit of measurement. The pictures/drawings/illustrations in this manual are for illustration only and are shown in miles per hour and feet as well as kilometers per hour and meters.



# Capabilities

## *Performance*

- Target Acquisition in 0.3 seconds  
(Dependent on environment and reflective characteristics of target)
- Speed Accuracy of one unit of measure

## *Advanced Input-Output*

- Remote Fire trigger switch
- Full Remote control via RS-232 port
- Data Collection via RS-232 port

## *Ease of Use*

- Menu Driven
- Head Up Display (HUD) shows both target and speed or distance data through the same sighting mechanism
- Optional Rechargeable NiMH or 9 volt Battery Handle
- Optional 12 Volt Cigarette Adapter
- Optional 8X Monocular
- Optional Monopole and Tripod for mounting
- Optional Mapping system upgrade
- Optional USB/SD Memory Drive

## *Environmental Features*

- Water Resistant
- Ruggedized Housing
- Rechargeable NiMH Battery Handles

**Optional accessories, carrying cases and cords in a variety of styles are available.**

## Chapter 2 Getting Started

# PACKING LIST

---

Please check to make sure the following items that were ordered are included in your shipment, such as:

- SpeedLaser® LIDAR Unit
- Battery Handle
- Carrying Case
- Battery Charger (if applicable)
- 12 volt Charging Cable (if applicable)
- User's Manual
- Warranty Card

Additionally, you may have received the following optional parts:

- RS-232 Serial Data Cable
- 8X Monocular
- Additional Battery Handles
- Additional optional charging cords and accessories

(Please see Appendix C for diagrams of some of these items.)

**SpeedLaser® Controls & Layout** (Typical - wording may vary in different versions. Drawings are for illustration only.)

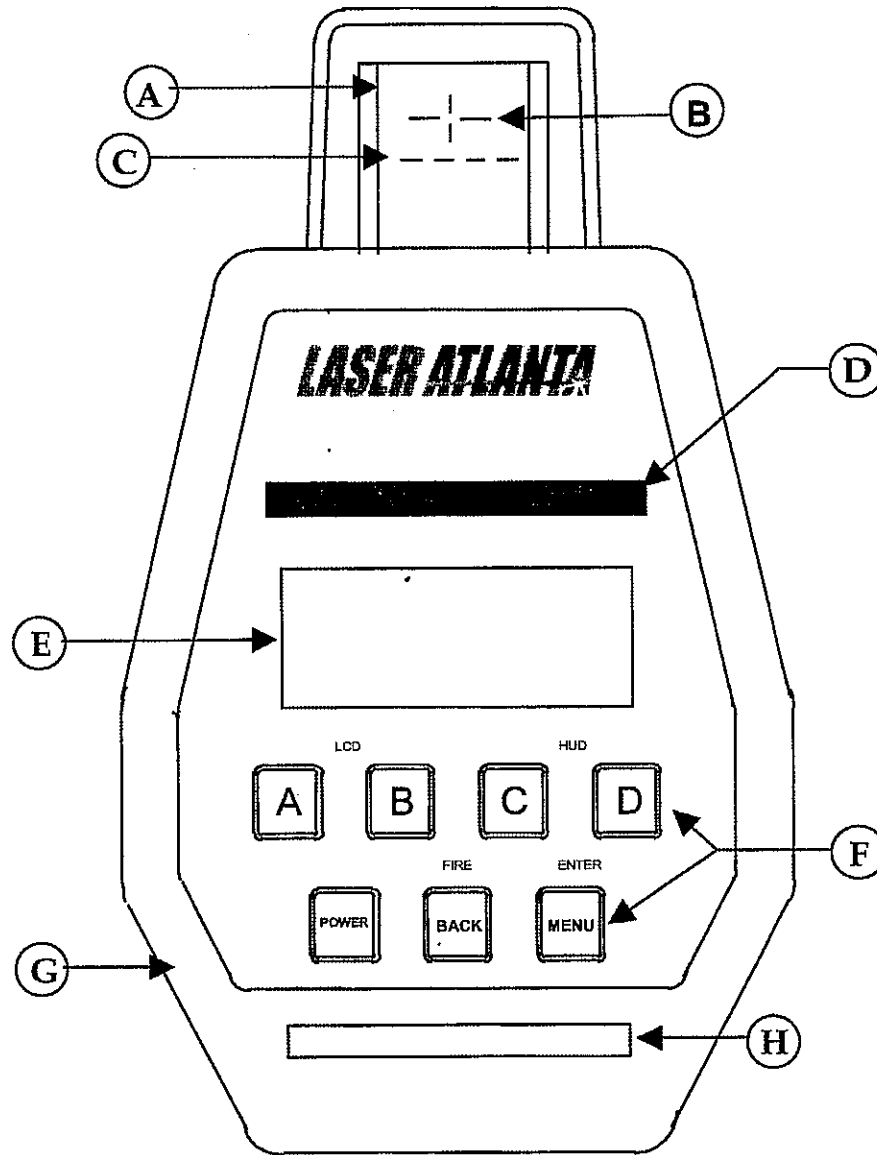

- |                          |                                 |
|--------------------------|---------------------------------|
| A: Head Up Display (HUD) | E: Liquid Crystal Display (LCD) |
| B: HUD Sighting Reticle  | F: Keypad Keys                  |
| C: HUD Character Display | G: Rear Bumper                  |
| D: Serial Number         | H: Optional Memory Drive Slot   |

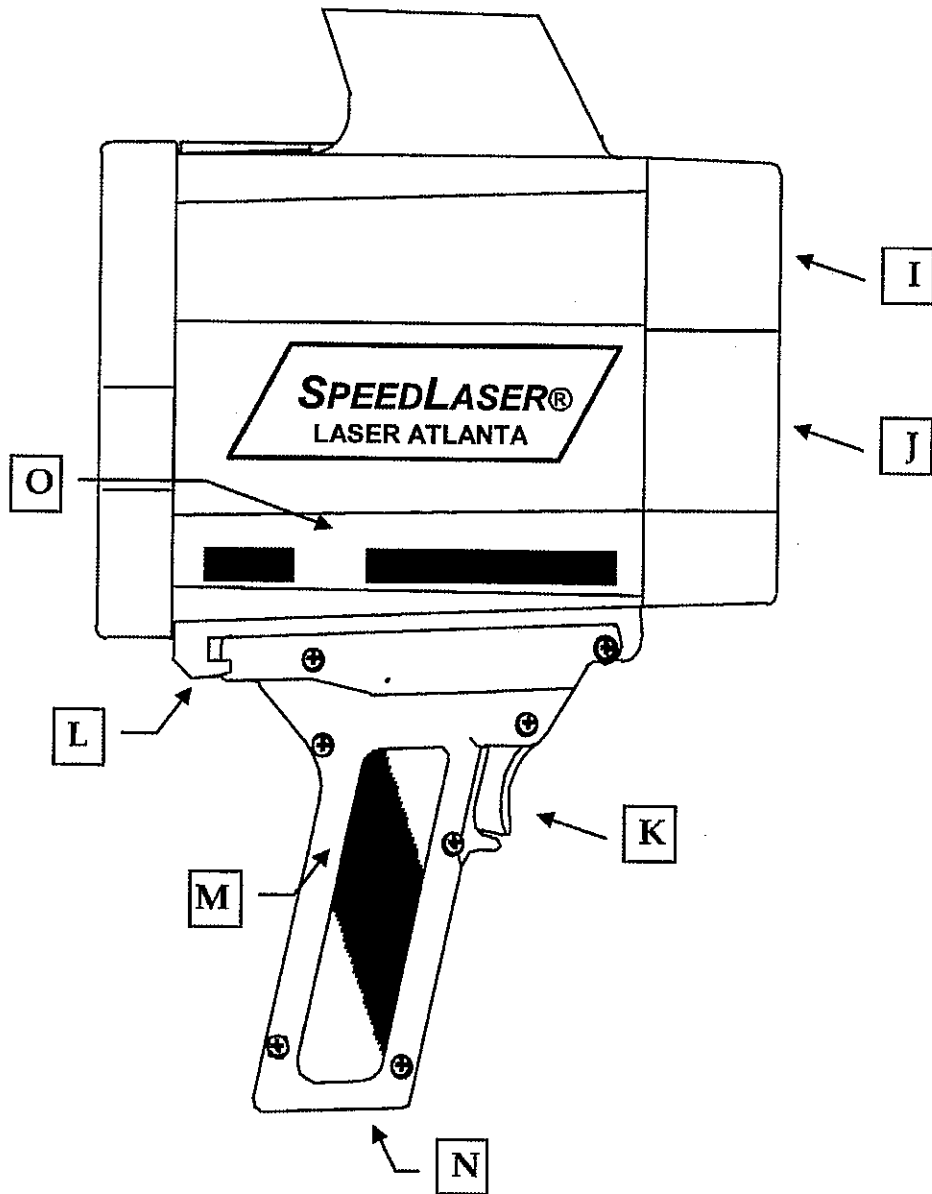

- |                    |  |
|--------------------|--|
| I: Transmit Optics | M: Battery Handle  |
| J: Receive Optics  | N: External Data/Charging Port<br>(Tripod mountable handle<br>has data port on the side) |
| K: Handle Trigger  | O: Laser Warnings  |
| L: Handle Latch    |  |

## Battery Handle Power

The SpeedLaser® may come equipped with a rechargeable battery handle shipped uncharged. You may need to charge it completely (10-12 hours) with the wall charger or 12 Volt cigarette cable before first use. Each handle provides an average of eight hours or more of continuous use per charge (hours vary based on use). Some orders come with the optional 9-volt handle (9-volt batteries not included) or extra rechargeable handles.

These handles are also capable of powering the SpeedLaser from a 12V source such as an automotive cigarette power adapter using the cable if provided. Plug the small circular connector onto the Charging Connector on the side of the handle and the cigarette adapter end into an automotive cigarette-power adapter. You can charge the handles in this manner while operating the unit. If charge light is not illuminated when connected to either charger, battery is not receiving a charge.

### To charge your battery handle:

1. Plug the circular connector into the Charging Connector on the side of the handle. Do not force the connector as it is keyed...slowly rotate the connector (holding the black rubber) and push gently until it clicks and locks into place.
2. Plug the charger into a standard 120 VAC power receptacle OR plug the cigarette adapter into a power source.
3. Charge the handle for ten to twelve hours.
4. To remove the connector, pull gently away from the handle on the outside of the metal connector nearest the handle.
5. Unplug the charger from the wall. The handle is now charged.

### CAUTION! DO NOT:

- Charge handles with chargers not supplied by Laser Atlanta.
- Short circuit the battery pins
- Charge handle for over sixteen (16) hours continuously

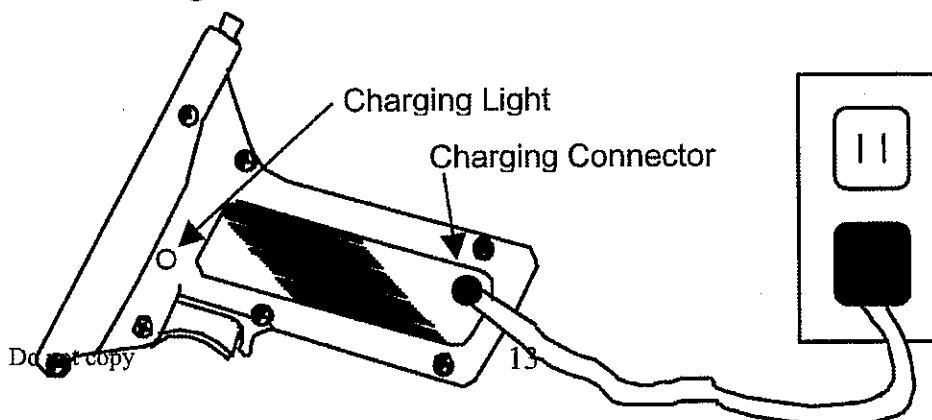

## Connecting a Handle

### To install a handle onto the SpeedLaser®:

1. Press the Handle Latch forward on the handle.
2. Push the front of the handle into the front Handle Catch on the bottom of the SpeedLaser®.
3. Rotate the rear of the handle upward.
4. Release the handle latch.

**NOTE:** Make certain the handle latch slides into position and secures the handle to the SpeedLaser®. If necessary, push the handle latch toward the back to secure the handle to the SpeedLaser®.

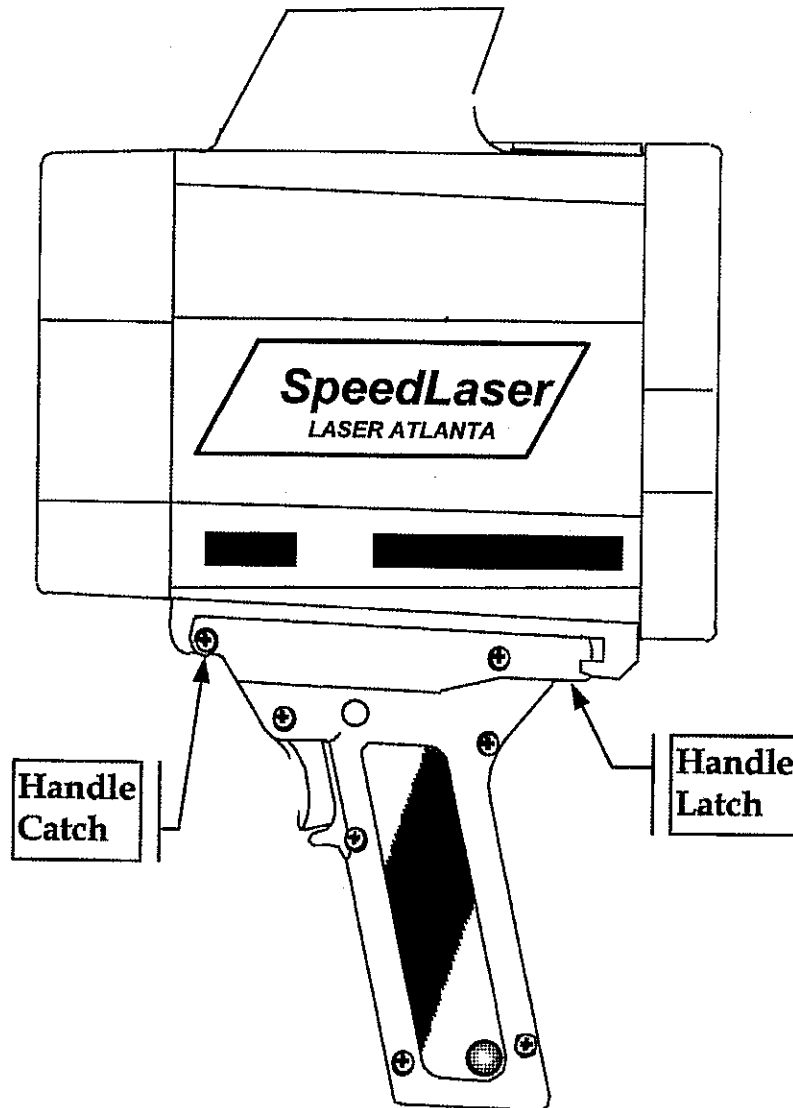

## Turning the SpeedLaser® ON and OFF

### To POWER ON

---

- 1) Press and hold the PWR key located on the back of the SpeedLaser® for approximately one second.

**NOTE:** The hardware and software Built In Test (BIT) automatically runs when the unit is first powered ON. When BIT is completed successfully the LCD will display "SYSTEM READY." or "Self-Test Passed". Either indicates that the BIT has been completed successfully.

### To POWER OFF

---

- 1) Press and HOLD the PWR key on the back of the SpeedLaser® (see note) for approximately three seconds.

**NOTE:** Keep the key pressed until "POWERING DOWN" is displayed on the LCD then release the keypad. If the button is not depressed for a long enough time, it toggles the LCD backlight ON and OFF.

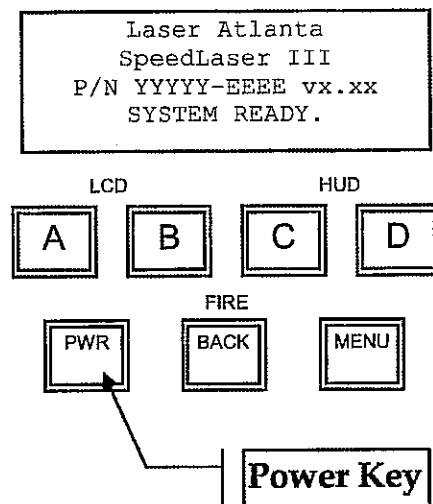



## Chapter 3

### Speed Measurement

When the SpeedLaser<sup>®</sup> is first turned ON, it automatically and quickly runs the Built In Test (BIT) functions. To capture a speed, simply follow the procedure below when the BIT is complete.

## SPEED DETECTION

**NOTE: Always verify operational procedures for Alignment Check.**

1. Align the HUD Sighting Reticule (+ symbol in the HUD) on the target you wish to measure the speed of.
2. Squeeze and hold the Handle Trigger until the speed is displayed.
3. Release the Handle Trigger to stop measurement, momentarily display the information in the HUD and lock information on the LCD. The LCD displays the information until one of the following occurs:
  - a.) The laser is fired.
  - b.) The unit is powered down (by the operator or typically after about 10 minutes of inactivity) or
  - c.) The menu button is pressed.

The speed will be shown in three places...twice on the rear right of the LCD and also momentarily in the HUD (when selected) character display. Notice that two of the speed displays are truncated to the nearest mph or km/h.

The distance to the target will be shown on the left side of the LCD.

**NOTE:** Pressing the trigger will take you to the *Speed Display Page* regardless of any other mode the SpeedLaser<sup>®</sup> may be in. (The exception is when in the TEST mode.)

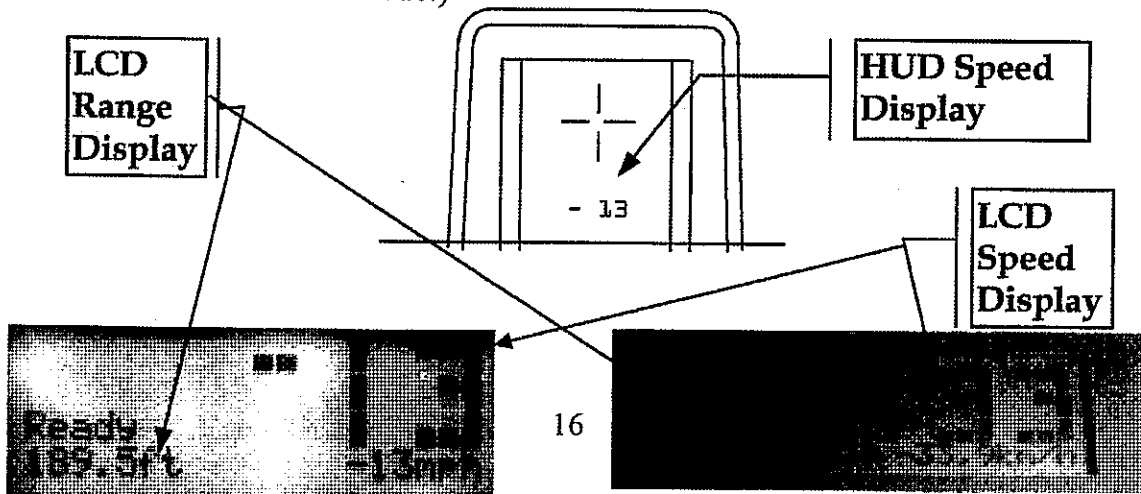

## APPROACHING AND RECEDING TARGETS:

The SpeedLaser® can measure the speeds of both approaching (oncoming) and receding targets.

When the target is receding, a "-" sign will precede the speed displayed in the HUD and on the LCD.

### Example of an Approaching target

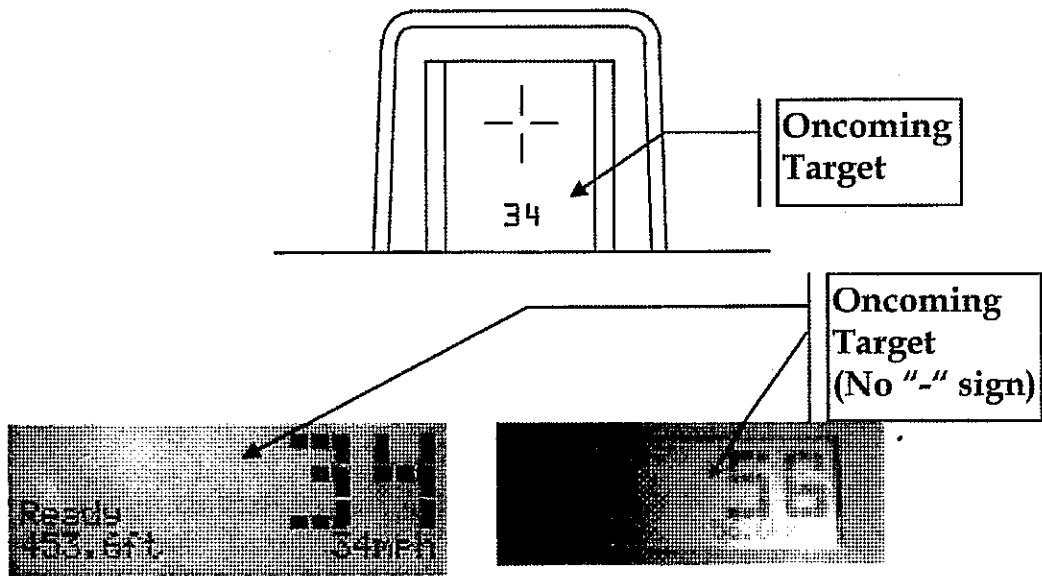

### Example of a Receding target

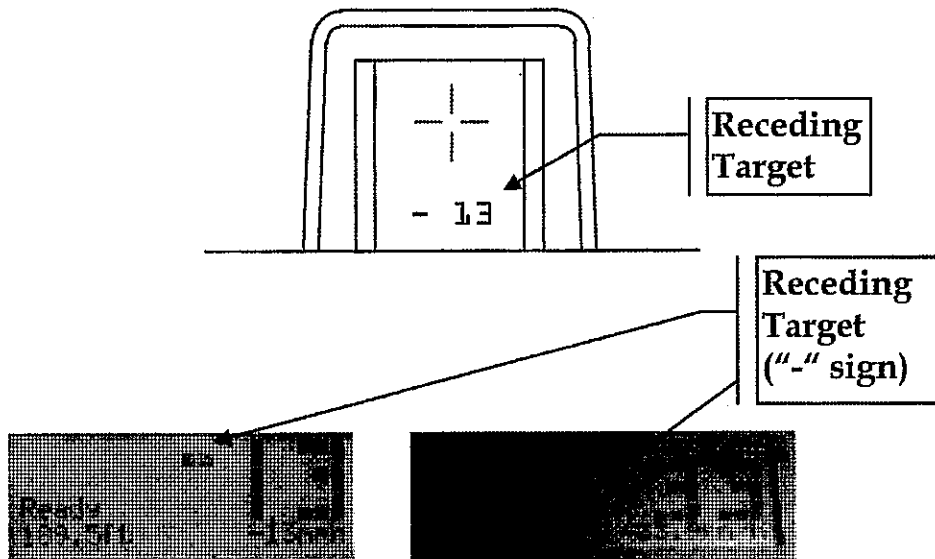

## **Manufacturer's Recommended Daily Test**

In keeping with NHTSA (National Highway Traffic Safety Administration) and IADLEST (The International Association of Directors of Law Enforcement Standards and Training) guidelines general operational considerations for LIDAR Speed Measurement devices, the operator must perform the following accuracy checks prior to beginning enforcement operations:

- 1) Internal Circuit Check
- 2) LED Segment Test
- 3) Range (Chronometer) Accuracy Test
- 4) Horizontal Sight Alignment Test
- 5) Vertical Sight Alignment Test

### **WHAT THE DAILY TEST ACCOMPLISHES:**

To ensure that the SpeedLaser® is in good working order, the SpeedLaser® should be tested using the Manufacture's daily test described later in this chapter. This test restores the factory default settings, checks the LIDAR hardware (including the program and dynamic memories), tests the displays and timing circuits, and then allows the operator to verify that the HUD aiming crosshairs are correctly aligned with the laser beam.

**NOTE:** The alignment crosshairs in the HUD are set at the factory and generally do not need realignment over the life of the SpeedLaser®.

#### **1) Internal Circuit Check**

When the operator presses Menu, followed by Test, (button A on the keypad), the SpeedLaser® runs a BIT (Built-In-Test) program. The BIT program tests the hardware and software by verifying that the SpeedLaser® firmware is loaded correctly and then checking that the processor is executing the data gathering, storing (memory), sorting, filtering, conversion and linear regression algorithms correctly.

#### **2) LED Segment Test**

This test allows the operator to verify that the seven-segment display, used to show speed of the target vehicle, is in good working order by displaying a simple known pattern. The operator can then confirm that each segment operates correctly and verify the presence of the aiming reticle.

### **3) Range (Chronometer) Accuracy Test**

The SpeedLaser® hardware ONLY measures Time. Range and Speed are computed values derived from multiple time measurements by the firmware, which was checked for proper operation during BIT. The design and accuracy of the firmware was verified as part of the IACP certification and subsequent testing processes.

This test uses the SpeedLaser®'s high-speed chronometer (timer) to measure the time it takes a light pulse to travel a known distance (i.e.; from the SpeedLaser® to a target at a known distance and back). Since the speed of light in air is known, the SpeedLaser® can calculate the range that the light pulse traveled. The operator then compares the reported range to the known distance to the target. To verify that the timing hardware is working correctly the computed range must match the known distance to within  $\pm 1$  foot (30 cm). At least two such comparisons using targets at least twenty (20) feet (6 meters) apart must be made.

In normal operation, the SpeedLaser® measures the time it takes for a light pulse to travel from the SpeedLaser® to a moving vehicle and back. The SpeedLaser® makes hundreds of such round trip time measurements each second, each time measurement is converted to a range and stored. When the SpeedLaser® has sufficient stored ranges, it performs a linear regression calculation that yields the speed of the vehicle. Numerous firmware filters are used to confirm the computed speed before it is displayed.

### **4) Horizontal Sight Alignment Test**

This is a test to confirm that the sighting system and the invisible light pulse emitted by the SpeedLaser® are aligned horizontally. The operator uses the sighting system to aim at an object and then confirms that the light pulses of the SpeedLaser® are hitting that object by observing that the SpeedLaser® is reporting the range to that object. The operator then moves the sighting system off of the object and observes that the reported range changes, just as the sighting system is no longer on the object and indeed should change.

### **5) Vertical Sight Alignment Test**

Same as Horizontal alignment test but in the vertical axis

When the SpeedLaser is initially powered ON, it automatically and very quickly runs a hardware and software Built In Test (BIT). When successfully completed, the LCD screen will display "SYSTEM READY" or "Self Test Passed". You are now ready to complete the following recommended daily tests, listed as #1 through #5, prior to conducting any enforcement activity.

## **Running the Manufacturer's Recommended Daily Tests**

### **1) Internal Circuit Check**

Press MENU followed by "A" on the keypad, which selects Test.

The LIDAR will then automatically:

- a) Enter the RESET & TEST Mode
- b) Restore factory default settings
- c) Run the hardware Built In Test (BIT)
- d) Run the software BIT including dynamic memory test
- e) Runs an LED count test (1111, 2222, ..., 9999)
- f) Defaults the HUD display to .8.8.8.8

Wait for "TEST PASS" or "Memory-OK" to be displayed. Either indicates that steps a to d have been completed successfully.

### **2) Light Segment Test**

Confirm e or f, the HUD is displaying aiming "+" with the data ".8.8.8.8".

### **3) Range (Chronometer) Accuracy Test**

Confirm that the LIDAR can correctly compute two or more known ranges using any **one of the following methods:**

- a) From one location, range to two targets at known distances.
- b) From two locations, range to one target at a known distance.
- c) Range to a random target, back up a known 'delta' distance, and confirm that LIDAR computes a new range with the same delta distance. Then back up a second, but different delta distance and confirm that LIDAR computes a new range that matches the new delta range.
- d) Combine method a) with the horizontal and vertical alignment tests (4 and 5) on next page. This requires that the targets used for the Horizontal and Vertical alignment are at different known ranges.

**Using your preferred method from above:**

- a) Stand at the selected position.
- b) Aim at selected target.
- c) Squeeze and hold trigger until tone sounds (range is computed).
- d) Confirm that reported range is within  $\pm 1$  foot (30 cm) of expected.
- e) Repeat steps a) thru d) using a known distance that is at least 20 feet (6 meters) different than the first known distance.

#### 4) Horizontal Sight Alignment Test

- a) Locate a vertical object (such as a utility pole) with open sky behind, preferably at a distance greater than 150 feet/45 meters.
- b) Aim to the left or right of the object, pull and hold the trigger.
- c) While keeping the trigger pulled, slowly sweep the crosshair sight across the vertical object.
- d) The distance to the pole should be displayed once the target edge is inside the HUD crosshair.
- e) Press D (Done/Next) to display next step.

#### 5) Vertical Sight Alignment Test

- a) Turn the unit 90 degrees sideways and repeat steps 4) a – e.
- b) Press MENU or DONE to exit Test Mode.

Note: If desirable, the horizontal and vertical alignment tests may be conducted using an horizontal object, such as a utility wire, with open sky. However, it will be necessary to turn the Lidar unit 90 degrees to conduct the horizontal test and return it to the upright position when testing the vertical axis or plane.

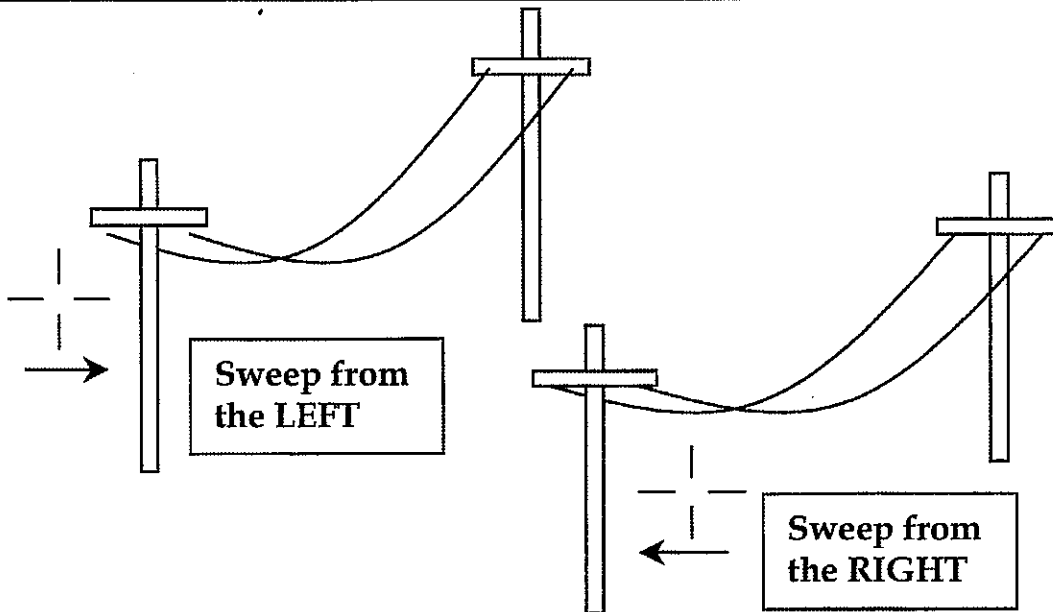

---

## Chapter 4

### User Settings

---

# INTENSITY AND CONTRAST

---

The intensity/contrast of the SpeedLaser<sup>®</sup> are set outside of the Menu system. Above each letter is a symbol that shows what the key function is outside of the menu. Before entering the menu you can activate the backlight, set the LCD contrast or set the HUD intensity.

While factory reset (Menu > Test) will automatically turn off the backlight, the LCD contrast and HUD intensity are only set by the user therefore do not change during the test. This allows an appropriate intensity/contrast level to be established before running the daily test.

### **LCD Backlight:**

Briefly pressing the PWR button will toggle the backlight ON and OFF.

### **LCD Contrast:**

Use the A and B keys to adjust the LCD Contrast:

- The A key adjusts the LCD Contrast DARKER.
- The B key adjusts the LCD Contrast LIGHTER.

### **HUD Brightness:**

Use the C and D keys to adjust the HUD Contrast:

- The C key adjusts the HUD intensity HIGHER.
- The D key adjusts the HUD intensity LOWER.

# THE MENU SYSTEM

The SpeedLaser® provides a number of user settable features to help the user in making range and speed measurements. These are accessible through sub-menus. The menu system is reached by pressing the MENU key located on the back of the SpeedLaser®.

- The top left of the LCD displays the Menu Name.
- The top right of the LCD displays the Menu page letter. This reflects the letter sequence of keys that have been pressed since the first menu page (Pg 0).
- Other lines list choices selectable by the A, B, C, and D keys.

The menu system is navigated via the following keys:

- A:** Used to select choice A
- B:** Used to select choice B
- C:** Used to select choice C
- D:** Used to select choice D
- PWR:** Release quickly to toggle backlight on and off
- PWR:** Hold for about three seconds to turn off the SpeedLaser®
- BACK:** Used to go back to the previous menu page
- MENU:** Used to enter/exit the Menu

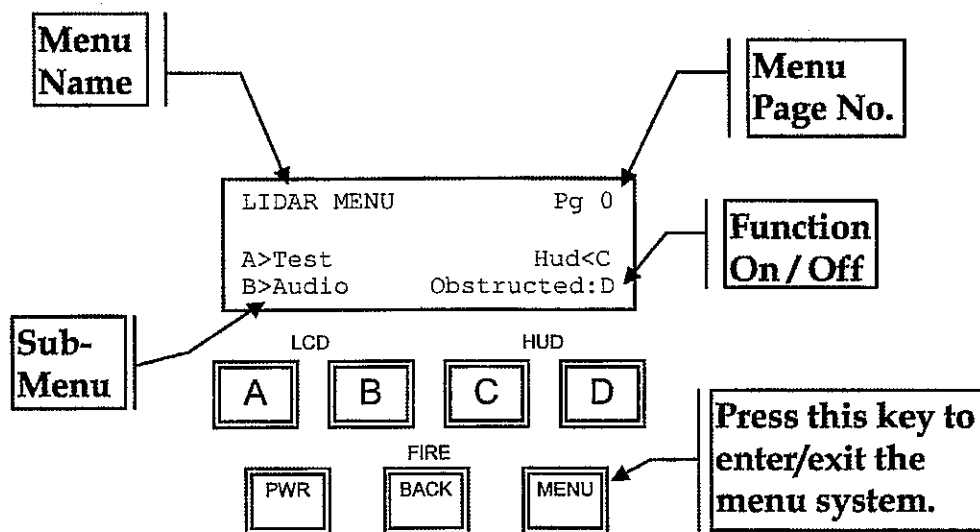



For each menu choice, on the outside left or right edge of the LCD is the letter matching the key to be pressed to activate the option. Between each key letter and its corresponding description is a symbol. The meanings of the symbols are as follows:

**> Or < (Greater/less than)**

When the “>” symbol appears next to a letter key, pressing that letter key will select the indicated sub-menu.

**: (Colon)**

When the “:” symbol appears next to a letter key, the named function is currently set to OFF. Pressing this letter key will turn ON the named function. If the function is of a “choose one” nature, then the related functions will automatically be turned OFF.

**@ (At)**

When the “@” symbol appears next to a letter key, the named function is currently set to ON. If the function is of an “on/off” type, then pressing this letter key will turn OFF the named function. If the function is of a “choose one” nature, then you must select one of the other functions to turn this function OFF.

**) Or ( (Parentheses)**

When the closed “)” or open “(” parenthesis symbol appears next to a menu selection, two presses of the corresponding key are required to enter the associated menu (represented in the menu tree, “LIDAR Menu Tree” Appendix with a double arrow). The first key press activates the selection using the default options as is shown on the LCD by the changing of the symbol to an ampersand (“&”).

A lower-case key letter designates a menu choice that is not currently selectable (usually because the necessary hardware is not present or because it is dependent upon another option).

Please refer to LIDAR Menu Tree Appendix.

---

Please note that the current settings are automatically **saved when you turn the unit off** and will not be lost even if the battery handle is removed after the unit is powered off.

When the daily **Test** is run, the SpeedLaser® automatically restores all common user settings to their factory default values. Certain user selectable preferences such as “Jammer Detect”, “LCD contrast” and “HUD intensity” are retained.

The remainder of this Chapter presents a diagram and description of each sub-menu.

To quickly access any desired menu, press the MENU key and then the sequence of letter shown at the top right of the display diagram on any page.

For example, to select the Audio Quality Chirp, you would press the following keys in sequence:

MENU | Audio | Q<sup>u</sup>ality Chirp *or* MENU | B | C

## Main Menu

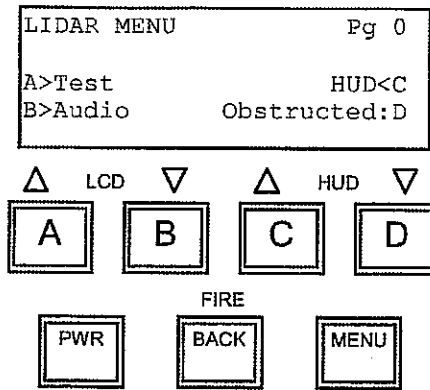

#	Action	Key
1	Turn On	PWR
2	Select MENU	MENU

The Main Menu is the starting menu page for all user configurable functions. These functions are divided into four groups:

- Test
- Audio
- HUD
- Obstructed

See the Menu Tree and the description pages that follow for instructions on using these settings.

**Reminder:** The user settings are remembered until the **Test** menu is run. The laser will revert to standard factory settings when the **Test** menu is selected.

**NOTE:** The hardware and software **Built In Test** functions are performed automatically upon powering the SpeedLaser.

# Test Mode

Performing the Daily Test (older versions use "Memory-OK" instead of "TEST PASS". Both messages are functionally identical.)

## MENU A

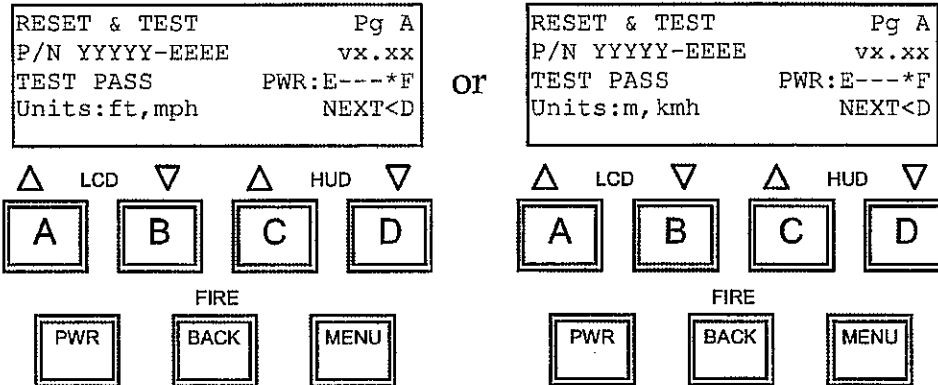

#	Action	Key
1	Turn On	PWR
2	Select MENU	MENU
3	Select TEST MODE	A

The Daily-Test performs the following functions:

- The SpeedLaser® setting are restored to their factory default values.
- The software Part Number and Version are displayed in the LCD.
- The program and storage memories are tested.
- The battery voltage is displayed on an Empty - - - Full scale.
- The speed and distance units of measure are displayed on the LCD. (Note: These units are pre-configured at the factory and cannot be set by the end-user.)
- All LED segments in the HUD are cycled through the numerals 1 to 9 and then finally displayed as .8.8.8.8
- Range (distance measurement) mode is automatically turned on. This allows the operator to perform the range (chronometer) and alignment checks (see procedure starting on page 20.)

If any of the diagnostic functions fail, a failure warning will be displayed on both the LCD and in the HUD. A warning tone will sound and the SpeedLaser® will prohibit firing of the laser. The operator should attempt to power the unit down and back on and run the daily-test again.

## Audio

Toggling the beeper tone ON and OFF

MENU B (your unit shows one of these configurations)

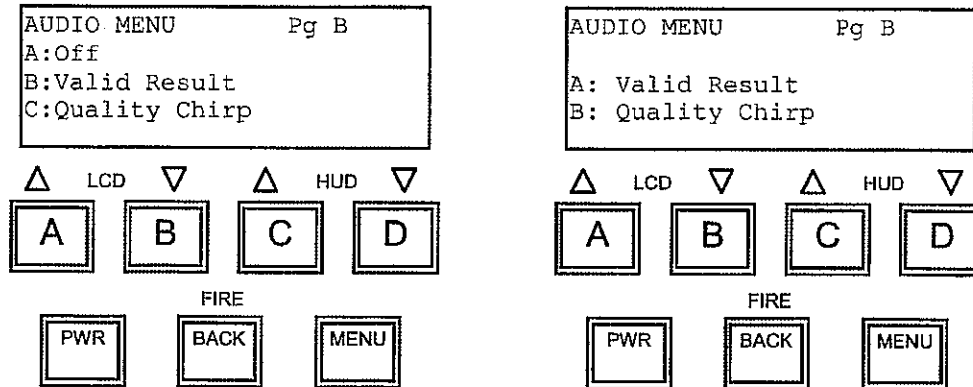

#	Action	Key
1	Turn On	PWR
2	Select MENU	MENU
3	Select AUDIO	B
4	Select preference    Off   Valid   Quality	A   B   C

"OFF" is not present on certain municipalities' versions

If selection *Off* is NOT selected, the unit will emit a short beep each time a menu key is pressed.

If selection *Valid Result* or *Quality Chirp* are selected, the audio beeper will sound for the following conditions:

*Valid Result*    The beeper will emit a tone when a valid speed or distance measurement is made.

*Quality Chirp*    When the SpeedLaser® is computing range and speed calculations (in Range Average or Real-time Range modes only), a tone representative of the quality of the received laser signal is sounded. When strong laser returns are acquired, the tone will be solid. Weaker returns will give a weaker, broken tone.

**NOTE:** The following conditions will signal an alarm regardless of the settings on this menu page.

*Voltage Low*    A solid tone will sound when the voltage is low.

*Fail*    Any failure mode will sound a solid tone.

## HUD Mode

Setting what information is displayed on the HUD (older versions do not have a choice of aiming as indicated by "d" in their display)

### MENU C

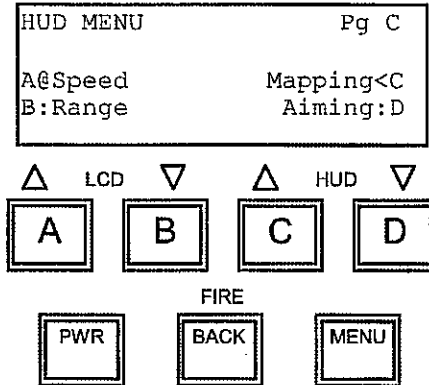

#	Action	Key
1	Turn On	PWR
2	Select MENU	MENU
3	Select HUD MENU	C
4	Select preference	A   B   C   D

This setting chooses what is displayed in the HUD; *Speed*, *Range*, *both Speed and Range*, or *Accident Mapping data* and selects the *Aiming Reticle Menu*

*Speed*      Select A to display Speeds in the HUD.

*Range*      Select B to display distances in the HUD.

## Both Speed and Range

Select both A and B to alternately display Speed and Distance in the HUD. The values will rotate between the current speed and the current range.

*Mapping*    Select C to use the SpeedLaser® with the optional mapping accessories to map an Accident Scene. This sets the SpeedLaser® to compute ranges using the stationary range only algorithm found in the Advantage™ Mapping/GIS product.

**Aiming** Pressing D selects the HUD Menu uses to control the appearance of the aiming reticle. (Lower case(d) indicates only crosshair mode is available on older units).

## AIMING MENU

Setting the appearance of the HUD aiming reticle  
MENU CD

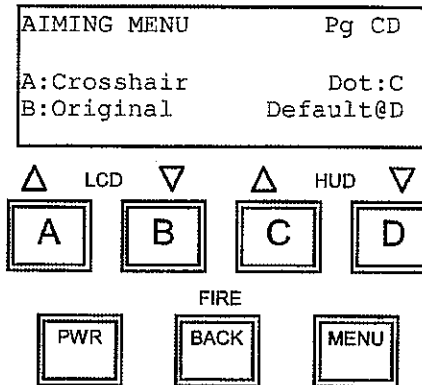

#	Action	Key
1	Turn On	PWR
2	Select MENU	MENU
3	Select HUD MENU	C
4	Select AIMING MENU	D
5	Select preference	A   B   C   D

*This setting chooses the appearance of the HUD aiming reticle. The four choices are shown on the next page*

**Crosshair** Select A to display a reticle with a gap aspect ratio similar to the end view of a vehicle. The width of the laser beam matches the width of the gap in the center of the reticle.

**Original** Select B to display a reticle with a square gap. The width of the laser beam matches the width of the gap in the center of the reticle.

**Dot** Select C to display a small dot in the center that will be located in the center of laser beam. The laser beam is larger than the dot.

**Default** Select D to display the small dot in the center that will be located in the center of laser beam and to display the original square gap reticle. The width of the laser beam matches the width of the gap in the center of the reticle.

AIMING MENU continued (diagrams below are indicative of the configurations)

**Crosshair**

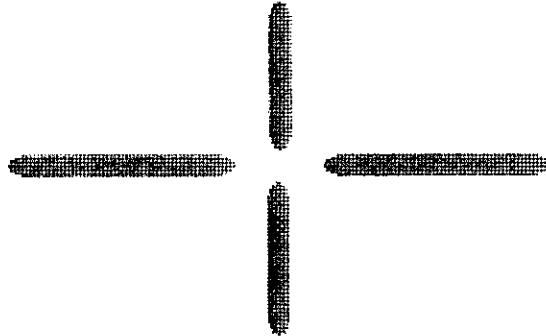

**Original**

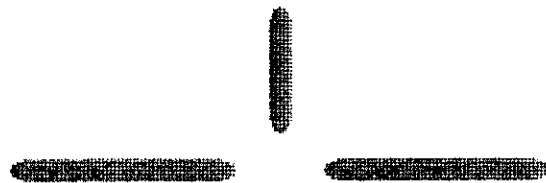

**Dot**



**Default**

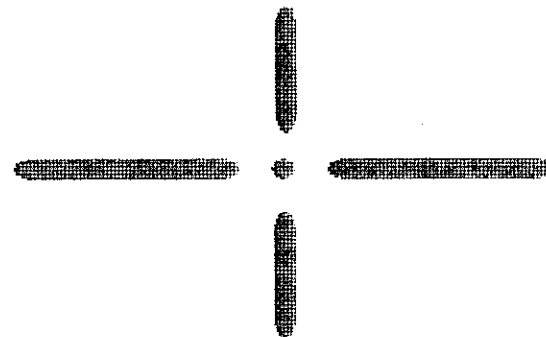



## Obstructed

Turning the Obstructed mode On / Off  
MENU D

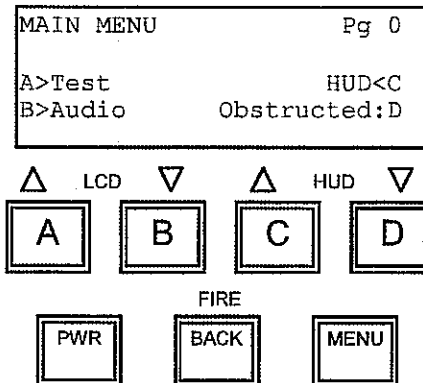

#	Action	Key
1	Turn On	PWR
2	Select MENU	MENU
3	Obstructed (Toggles On / Off)	D

Set to ON when firing the LIDAR through the patrol vehicle window, or when RAIN, SNOW, FOG or other OBSTRUCTIONS are present.

Normally LIDARs attempt to compute the speed of the first object that each laser pulse strikes. When standing in the open on a clear day this works well. But when a LIDAR is used from inside a vehicle or when weather is inclement or when objects like bushes and signposts partially block the view of the target vehicle, this approach does not work as well.

The SpeedLaser® Obstructed On/Off setting is an advanced filtering mode that allows the SpeedLaser® to process multiple ranges for each laser pulse. The LIDAR sees both the target vehicle and the obstructing object (rain, patrol vehicle window, snow, chain link fence, etc) and can filter out the random items like snow and the obstructing items like the window, allowing speed to be computed for the selected target vehicle.

This method does not require limiting the minimum range or having the operator set up some target window. In fact, Obstructed works from the standard minimum range of 5 feet (2 meters) out to over 2700 feet (900 meters).

## APPENDIX A

### TROUBLESHOOTING PROCEDURES

If you suspect your SpeedLaser® is malfunctioning, please check the following items:

#### Troubleshooting:

Symptom:	Possible Cause:
SpeedLaser® will not power on	Battery Handle not charged sufficiently; 12V DC coiled power cord not plugged in; Brass contacts on bottom of the unit need to be cleaned. Take a pencil eraser & clean contacts from corrosion.
All Black Dots appear on the LCD screen	LCD contrast needs to be adjusted. See Chapter 4 on 'How to adjust the LCD contrast'.
Cannot see anything on the LCD screen - Blank	LCD contrast needs to be adjusted. See Chapter 4 on 'How to adjust the LCD contrast'.
Cannot see HUD displays - crosshairs, DOT, or Both	HUD brightness set to low or to high. See Chapter 4 on 'How to adjust the HUD contrast'.
Continuous beeping noise coming from unit after it is powered on	Make sure that the battery handle is fully charged; clean the brass contacts on the bottom of the unit. Take a pencil eraser & clean the contacts from corrosion.
Battery handle not fully charging.	Battery handle may be worn & needs to be replaced or refurbished.
SpeedLaser® will not range to distant targets	Target is not reflective enough; Target is too far away; Lens blocked or fogged.

#### Error Messages:

Error Message	Message Meaning	Operator Action
EEPROM Data Not Found	SpeedLaser® setup defaults not located	Cycle Power
HELP	Voltage too low	Recharge the Battery Handle
Low Battery	Voltage too low	Recharge the Battery Handle

If you are unable to resolve the problem on your own, please contact us.

If you need to return your unit for service, please call first to receive a Return Materials Authorization (RMA) number.

**PLEASE SEE BACK COVER FOR CONTACT INFORMATION REGARDING REPAIRS AND SALES**

## **APPENDIX B**

### **CARE AND MAINTENANCE**

#### **General Care Considerations:**

##### **DO:**

- Transport the SpeedLaser® in its carrying case
- Occasionally clean the SpeedLaser® Optics (see procedure below)

##### **DO NOT:**

- Point the SpeedLaser® at the sun
- Place on unstable surfaces
- Open the SpeedLaser®

### **CLEANING THE SPEEDLASER®'S OPTICS**

---

**WARNING!** The SpeedLaser®'s optical surfaces are coated glass. Care must be taken when cleaning these surfaces. Scratching the lenses may lead to reduced range.

#### **Surfaces to Clean:**

The LASER TRANSMITTER OPTICS, RECEIVER OPTICS, HUD COMBINER GLASS, and HUD SEALING WINDOW may be cleaned as needed.

#### **Materials:**

1. Lint-free cloth or optical cleaning tissue
2. Soft bristled brush
3. Isopropyl Alcohol

#### **Method:**

1. Brush loose debris from optical surfaces with brush or cloth.
2. Moisten cloth with isopropyl alcohol.
3. Gently wipe optical surface in a circular motion. Change tissue if any debris is visible.

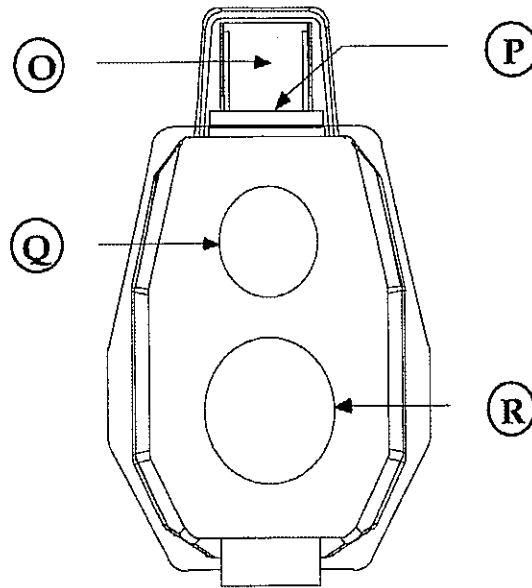

**P.** HUD SEALING WINDOW  
**O.** HUD COMBINER GLASS

**R.** RECEIVER OPTICS  
**Q.** TRANSMITTER OPTICS

# APPENDIX C

## *SpeedLaser® & ACCESSORIES*

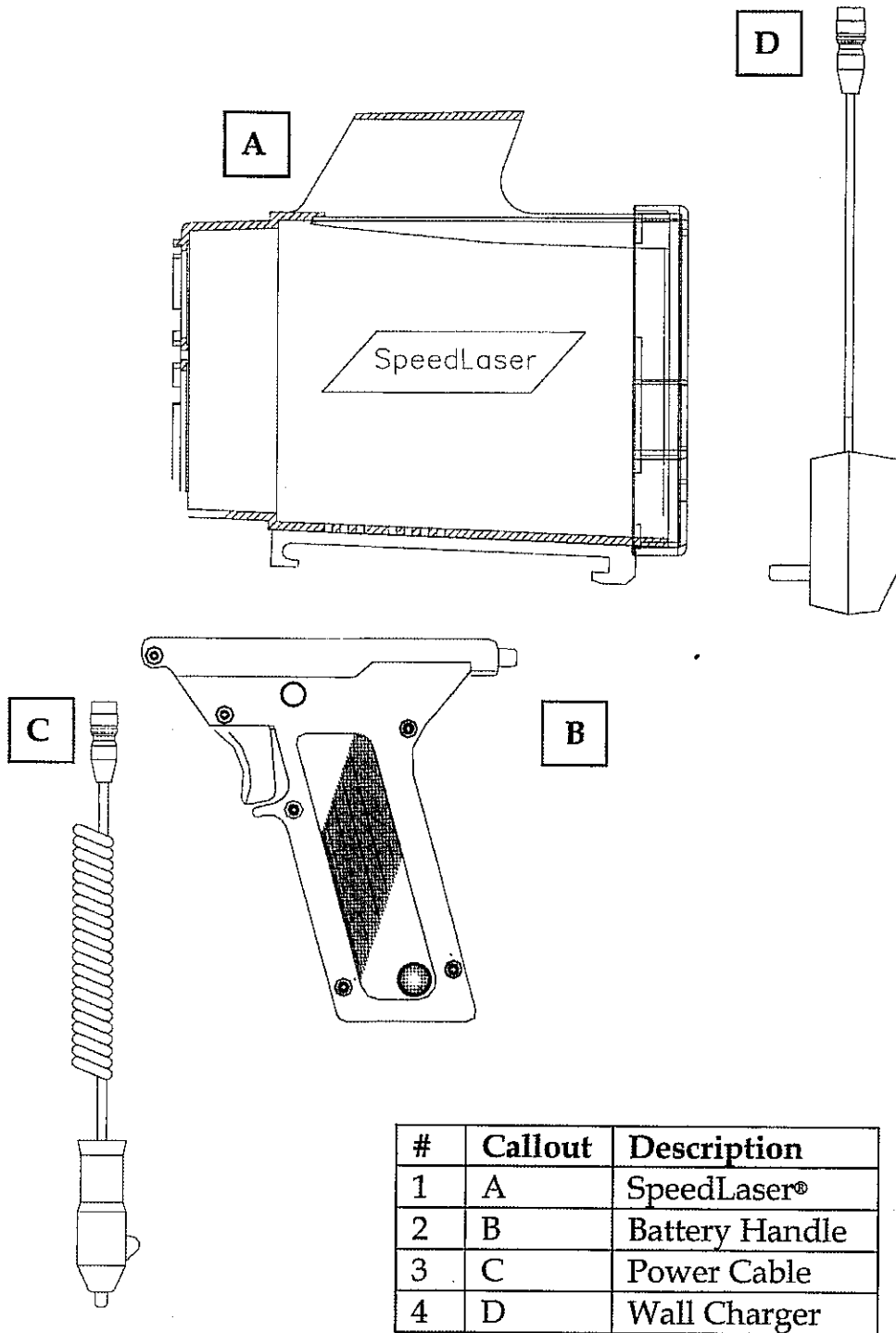

## Appendix D

### MEASURING SURFACE DATUM

The measuring surface datum is located 4 inches/10cm back from the face of the glass front of the unit. (This location corresponds to the vertical center of gravity of the unit.)

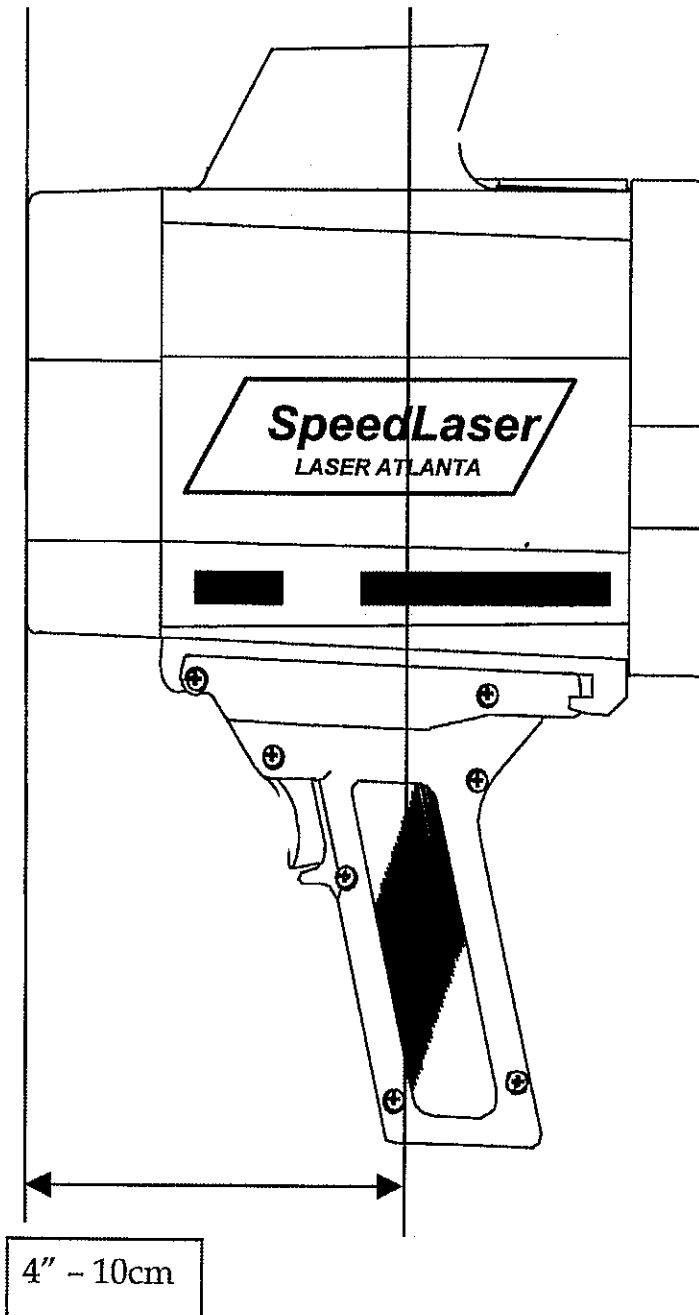

## Limited Warranty

Laser Atlanta warrants all SpeedLaser® LIDAR products to be free from defects in materials and workmanship under normal use and service for which such products are intended (specifically excluding defects or damage caused by misuse, negligence, droppage or accident) for a period of one (1) year from date of purchase. This warranty specifically excludes accessories, batteries and software. Accessories' warranty period is 90 days from date of purchase. During this warranty period Laser Atlanta will replace defective materials and correct faulty workmanship at no charge, provided the product is returned to Laser Atlanta within the warranty period. If Laser Atlanta is unable to replace defective materials or correct faulty workmanship, Laser Atlanta will replace the product at no charge. These are your sole remedies for any breach of warranty. Laser Atlanta shall not be liable for any loss or damage resulting, directly or indirectly, from the use or loss of use of such product.

## Return Policy

It is Laser Atlanta's policy and objective to allow prospective purchasers ample opportunity to become familiar with our products prior to purchase. We do so through our product rental, lease and demonstration programs. Customer satisfaction is very important to Laser Atlanta and we make every attempt to please customers whenever possible.

We are committed to designing and manufacturing products to the highest standards of quality and reliability. We offer a limited warranty that covers all materials and workmanship. In spite of our best efforts we do not want customers to incur unreasonable inconvenience due to equipment failure. Laser Atlanta will replace any product, or make a full refund, if repairs cannot be made to the satisfaction of the customer within the initial thirty (30) days of ownership. After the initial thirty (30) days of ownership Laser Atlanta will honor its warranty through either the repair or replacement of any malfunctioning products during the warranty period.

This warranty supercedes and voids all prior versions.

© Copyright 2007 Laser Atlanta LLC

Reproduction, adaptation, or translation of this manual is prohibited without prior written consent of Laser Atlanta LLC, except as allowed under copyright laws.

### **Firmware Version 1.00 and above**

© Copyright 1995-2007 Laser Atlanta LLC

The programs that control this product are copyrighted and all rights are reserved. Reproduction, adaptation, or translation of those programs without prior written consent of Laser Atlanta LLC is prohibited.

SpeedLaser®, Advantage™, and ProFiler™ are trademarks of Laser Atlanta LLC. Any other logos or trademarks are the property of their respective owners.





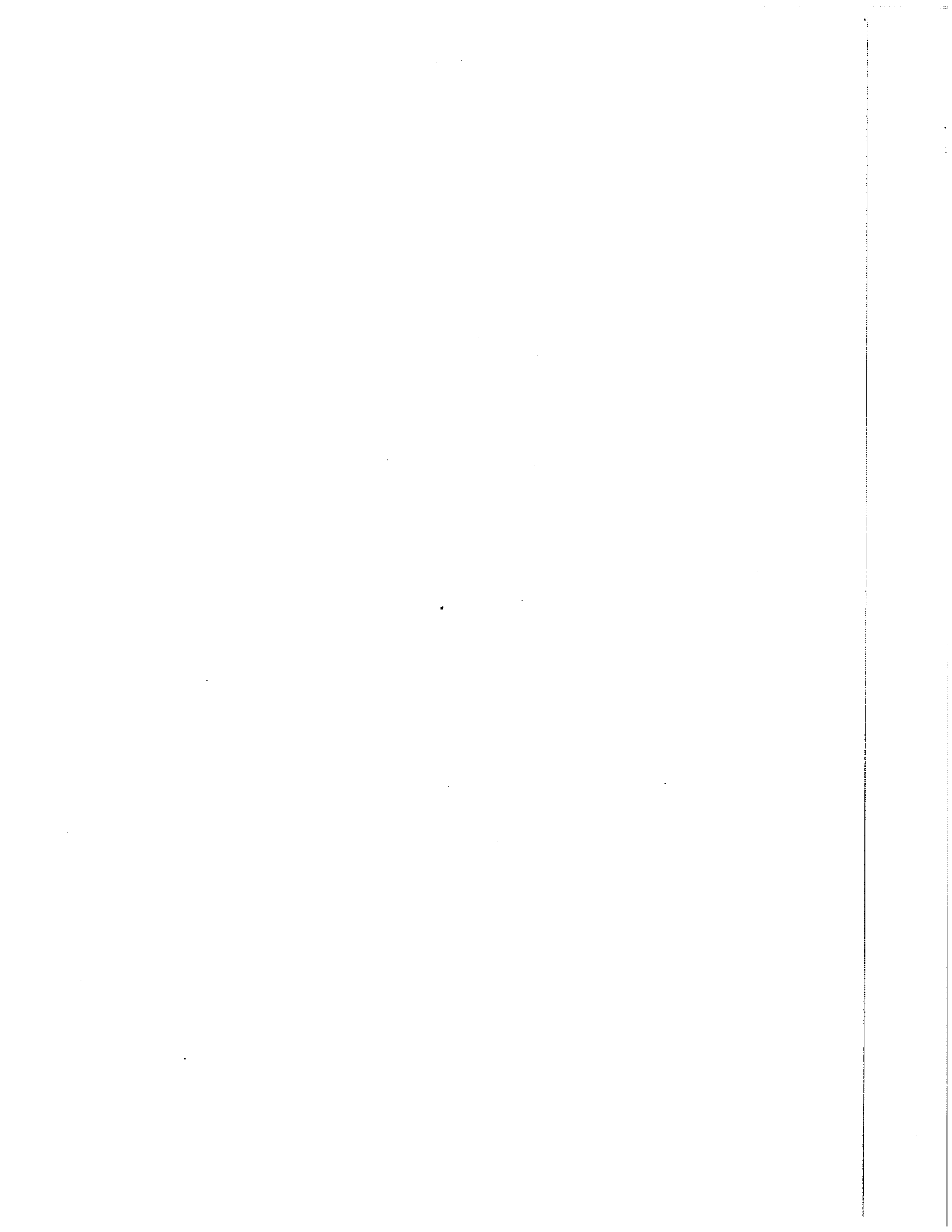

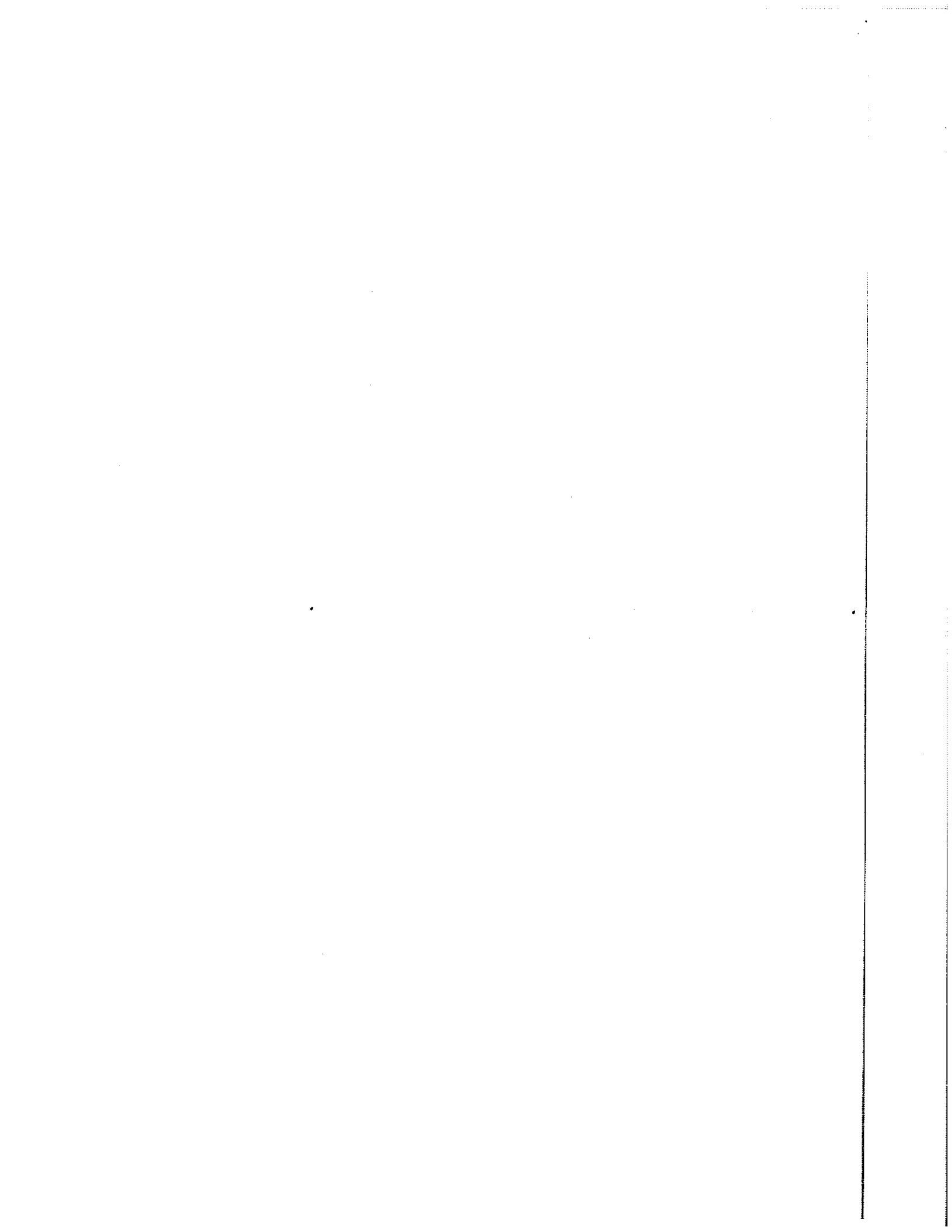

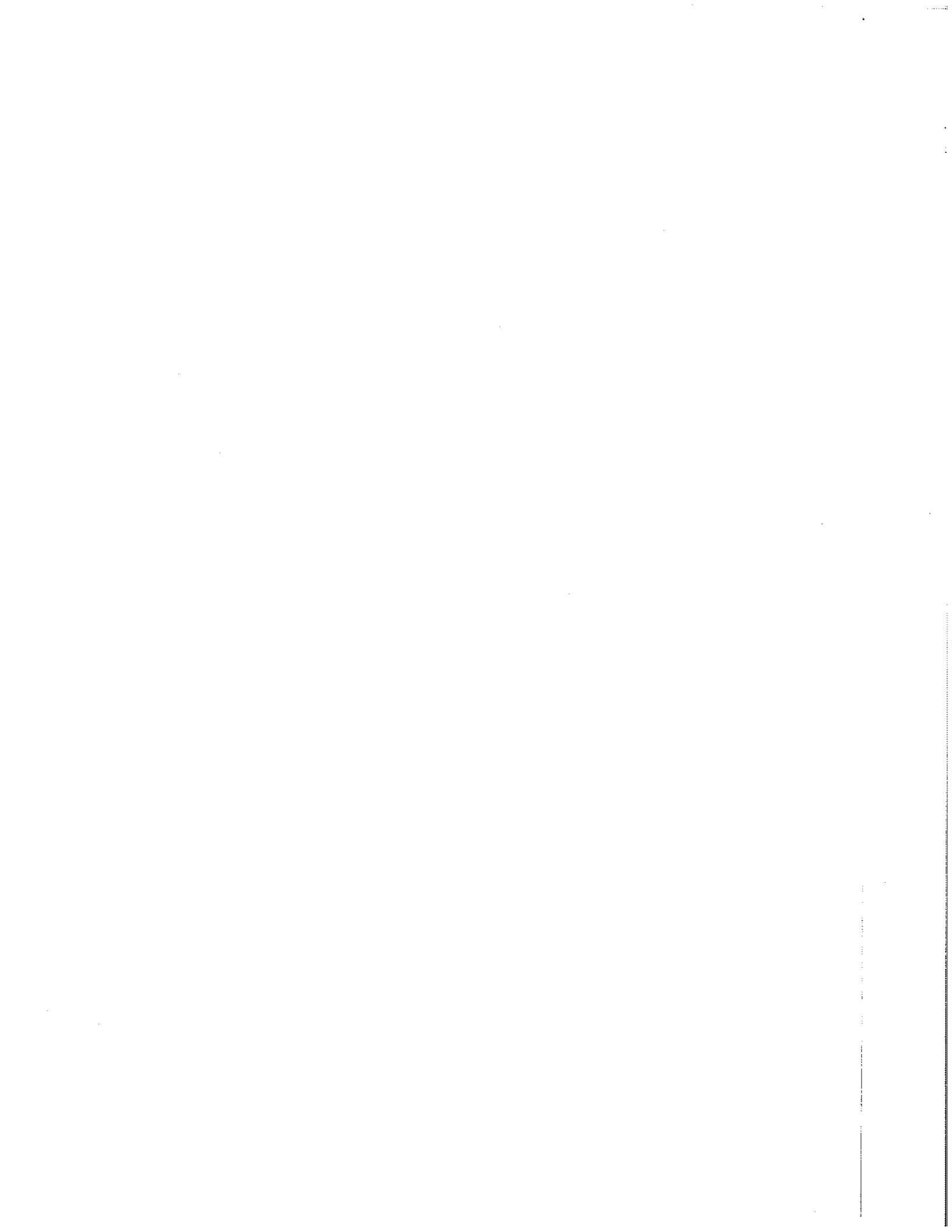

# Manufactured for the Speed Measurement Experts at



133 Walgreen Road  
Ottawa Ontario K0A 1L0  
Toll Free (800) 331-5815  
Fax (613) 831-6610  
E-Mail: [sales@davtech.ca](mailto:sales@davtech.ca)  
Website: [www.davtech.ca](http://www.davtech.ca)

**PLEASE CONTACT US AT THE ABOVE PHONE  
AND ADDRESS FOR SALES, REPAIR AND  
TECHNICAL QUESTIONS.**

---

P/N 40150