

METRIC
ALL DIMENSIONS IN MILLIMETRES

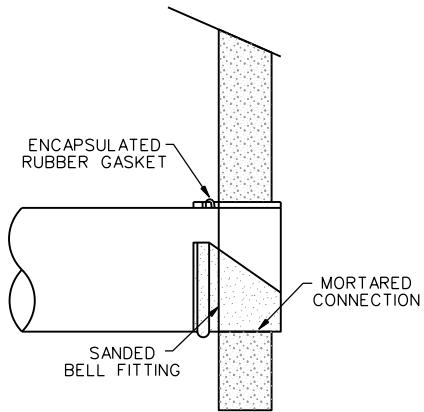

SAND COLLAR

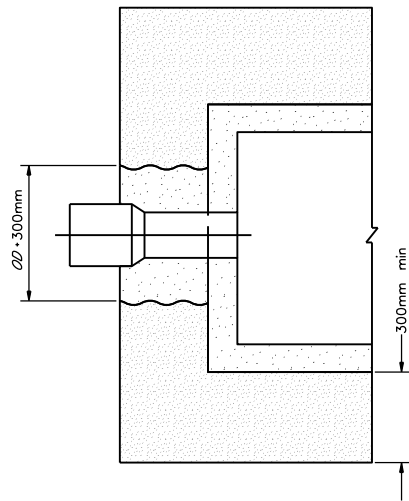

SECTION A-A

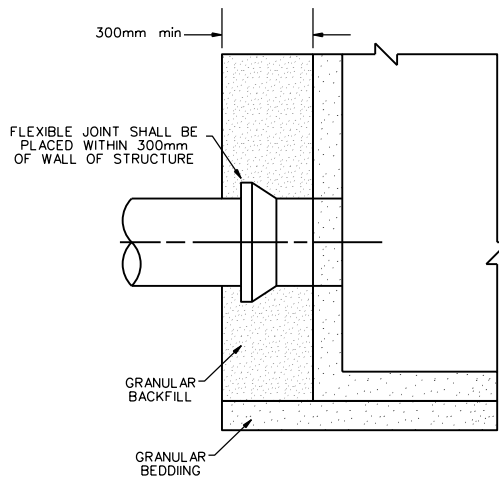

ELEVATION
FLEXIBLE JOINT
FLEXIBLE PIPE

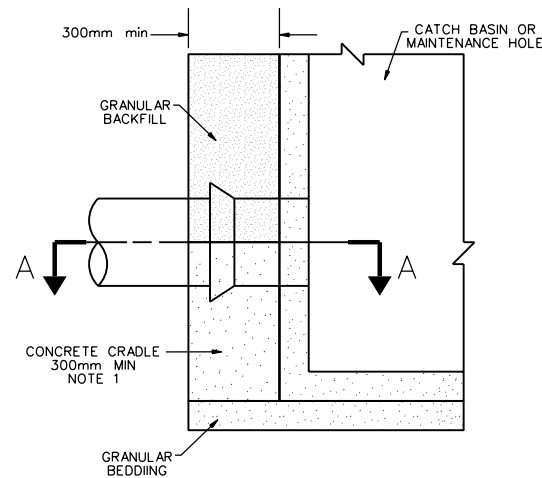

ELEVATION
CONCRETE CRADLE
RIGID PIPE

NOTES

1. ALL PVC PIPE SHALL HAVE A 'MANHOLE ADAPTOR' UNIT WITH A SAND SURFACE ORTARED INTO THE CONCRETE STRUCTURE.
2. NO FIELD-FABRICATED SAND COLLARS ALLOWED.
3. ALL CONCRETE SHALL BE C-2, 32MP_a AT 28 DAYS.
4. MANHOLE ADAPTORS (SAND COLLARS) SHALL BE FABRICATED BY AN APPROVED SUPPLIER.
5. SAND COLLARS SHALL BE MANUFACTURED WITH THE SAME MATERIAL AS THE PIPE.



STANDARD
CONNECTION AT PRECAST CATCH
BASIN OR MAINTENANCE HOLE

EFF. DATE	2016-09-21	SCALE	N.T.S.
REV.	2016-09-21	STANDARD No.	2114.040