

METRIC
ALL DIMENSIONS IN MILLIMETRES

PLAN VIEW

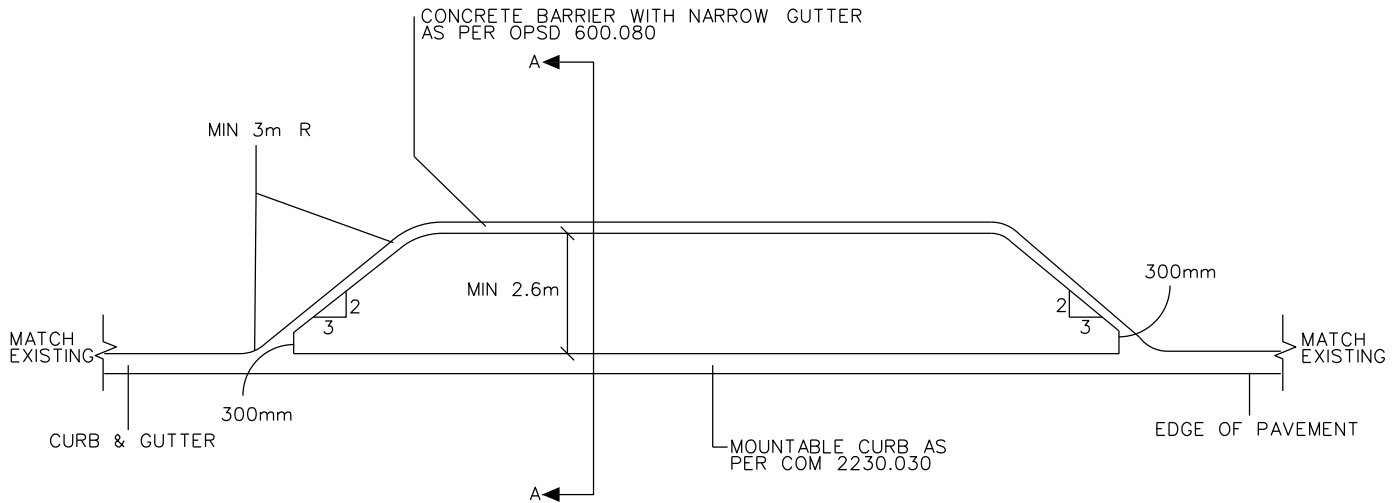

SECTION A-A

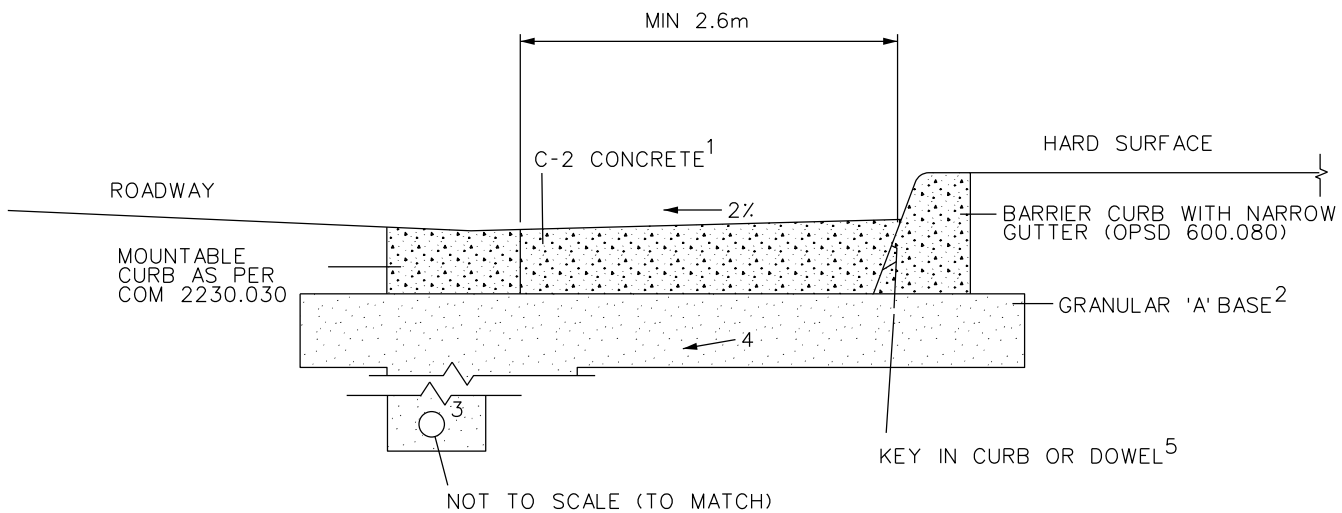

NOTES:

1. 225mm C-2 CONCRETE, REINFORCED WITH APPROVED FIBRE MEETING OR EXCEEDING ASTM C1116 FOR SYNTHETIC FIBRE REINFORCEMENT
2. GRANULAR 'A' BASE SHALL BE 20mm AND GRADED TO PROVIDE A UNIFORM THICKNESS OF 225mm FORR THE CONCRETE LAY-BY.
3. SUBDRAIN SHALL BE INSTALLED DIRECTLY BELOW THE MOUNTABLE CURB AND SURROUND BY 6mm WASHED CHIP STONE AS PER CITY STD 2112.111
4. BASE UNDER PARKING LAY-BY SHALL BE SLOPED TOWARDS SUBDRAIN
5. FOR NEW CONSTRUCTION, USE KEY. FOR RETROFIT CONDITION, USE DOWEL (DOWEL SPACING = < 600mm)



MISSISSAUGA

STANDARD
PARKING LAY BY DETAIL

EFF. DATE		SCALE	N.T.S.
REV.	1	2019-04-02	STANDARD No. 2230.031