

NOTES:

1. ALL DIMENSIONS SHOWN ARE FROM TOP OF POLE, EXCEPT AS NOTED.
2. ALL HOLES SHALL BE $\frac{3}{4}$ " IN DIAMETER.
3. IN ALL CASES, IDENTICAL HOLES SHALL BE PLACED 1" BELOW, AND $90\frac{3}{4}$ " TO DIMENSIONED HOLES.
4. RACEWAYS SHALL BE 2" MINIMUM DIAMETER.
5. POLE SHALL BE PARTIALLY PRESTRESSED AND BE MADE IN ACCORDANCE WITH CSA STANDARD A14-00 (OR LATEST EDITION) AND THIS DRAWING.
6. REFER TO STANDARD 5-8 TO 5-10 FOR PURCHASING REQUIREMENTS.
7. THE PURPOSE OF THESE HOLES IS TO PREVENT SLING SLIPPAGE DURING MATERIAL HANDLING.

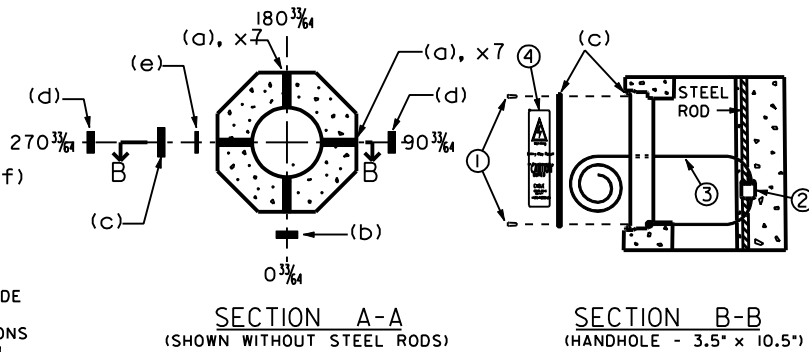

Item	Description	Qty
(a)	3/4" DIAMETER FORMED THROUGH HOLE	14
(b)	WIRING APERTURE, 2.25" X 3.5" (POLE TOP)	1
(c)	CAST METALLIC HANDHOLE FRAME AND COVER, 3.5' X 10.5' c/w WARNING DECAL	1
(d)	WIRING APERTURE, 2.5" X 5" (BELOW GRADE)	2
(e)	POLE IDENTIFICATION PLATE	1
(f)	CAPSEAL X75 OR DISTRIBUTOR'S APPROVED EQUIVALENT, 12' HIGH	2 coats
①	1/4" - 20 x 3/4" TAMPER PROOF ALLEN KEY BUTTON PAN HEAD STAINLESS STEEL	2
②	DOUBLE CRIMP CONNECTOR	1
③	*6 AWG (MINIMUM) STRANDED COPPER WIRE: -CRIMPED TO STEEL ROD AND HANDHOLE FRAME-EXTENDED 12" OUTSIDE HANDHOLE	++
④	WARNING DECAL AS PER STANDARD 5-125	1

++ - LENGTH TO SUIT

METRIC/IMPERIAL

DIMENSIONS SHOWN IN METRIC AND IMPERIAL UNITS



STANDARD
12.2 m (40 ft) CLASS B
OCTAGONAL CONCRETE STREETLIGHT
POLE DETAIL

EFF. DATE	2002-01-01	SCALE	N.T.S.
REV.		STANDARD No.	3100.120