

This drawing is an instrument of service, it is provided by and is the property of Turner Fleischer Architects Inc. The contractor must verify and accept responsibility for all dimensions and conditions on site and must notify Turner Fleischer Architects Inc. of any variations from the supplied information. This drawing is not to be scaled. The architect is not responsible for the accuracy of survey, structural, mechanical, electrical, etc. information shown on this drawing. Refer to the appropriate consultant drawings before proceeding with the work. Contractor must conform to all applicable codes and requirements of all relevant building jurisdictions. The contractor working from drawings not specifically marked "For Contractor" must assume full responsibility and bear costs for any corrections or damages resulting from his work.

### TYPICAL PARKING DIMENSIONS:

aisle width: MIN 7m

TYPICAL PARKING SPACE:  
MIN 2.6 x 5.2 x 2.0m HIGH

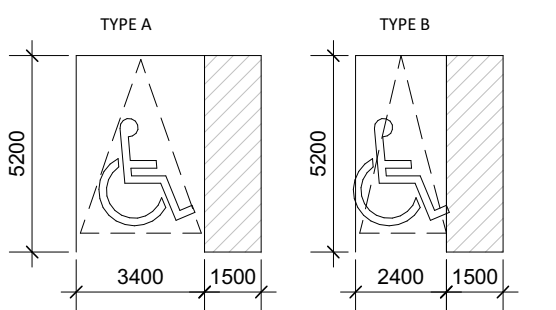
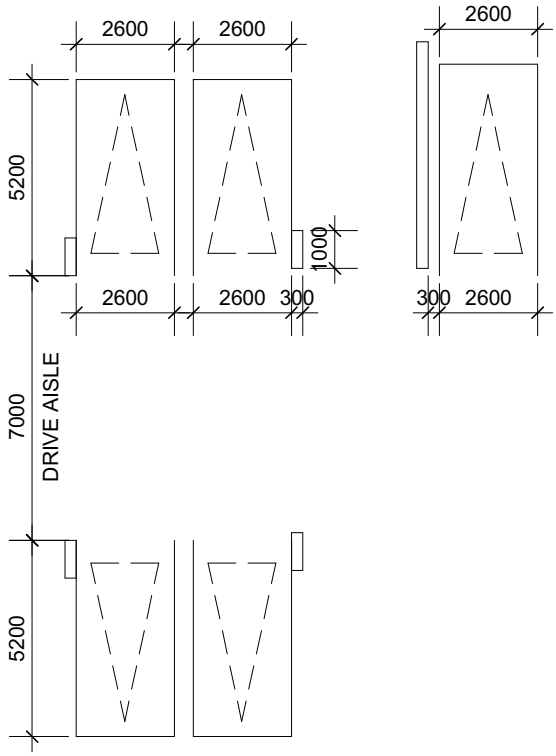

### LEGEND

WALL/COLUMN-MOUNTED CONVEX MIRRORS

V VISITOR PARKING

The minimum width of a parking space, other than an accessible parking space or parallel parking space, shall be increased to 2.75 m where the length of one side of the parking space abuts a building, structure or part thereof, except for a building, structure or part thereof, that extends 1.0 m or less into the front and/or rear of the parking space.

2	2021-03-24	REISSUED FOR REZONING	DV
1	2020-06-16	ISSUED FOR REZONING	DV
#	DATE	DESCRIPTION	BY

PROJECT  
**18.150FS**

420 LAKESHORE ROAD E, MISSISSAUGA, ON  
APPLICATION # - OZ 20/009 W1

DRAWING  
**UNDERGROUND LEVEL 01**

PROJECT NO.	18.150FS
PROJECT DATE	2021-03-30
DRAWN BY	DV
CHECKED BY	RMM
SCALE	As indicated

DRAWING NO.  
**RZ103**



ENOLA AVENUE