

This drawing, as an instrument of service, is provided by and is the property of Turner Fleischer Architects Inc. The contractor must verify and accept responsibility for all dimensions and conditions on site and must notify Turner Fleischer Architects Inc. of any variations from the supplied information. This drawing is not to be scaled. The architect is not responsible for the accuracy of survey, structural, mechanical, electrical, etc. information shown on this drawing. Refer to the appropriate consultant drawings before proceeding with the work. Contractor must conform to all applicable codes and requirements of all relevant governing jurisdictions. The contractor working from drawings not specifically marked "for Contractor" must assume full responsibility and bear costs for any corrections or damages resulting from his work.

### PARKING LEGEND

EV EVSE PARKING

EV-R EV ROUGH-INS

CONVEX MIRROR

### STANDARD PARKING DIMENSIONS:

AISLE WIDTH: MIN 7m

TYPICAL PARKING SIZE:  
MIN 2.6 x 5.2

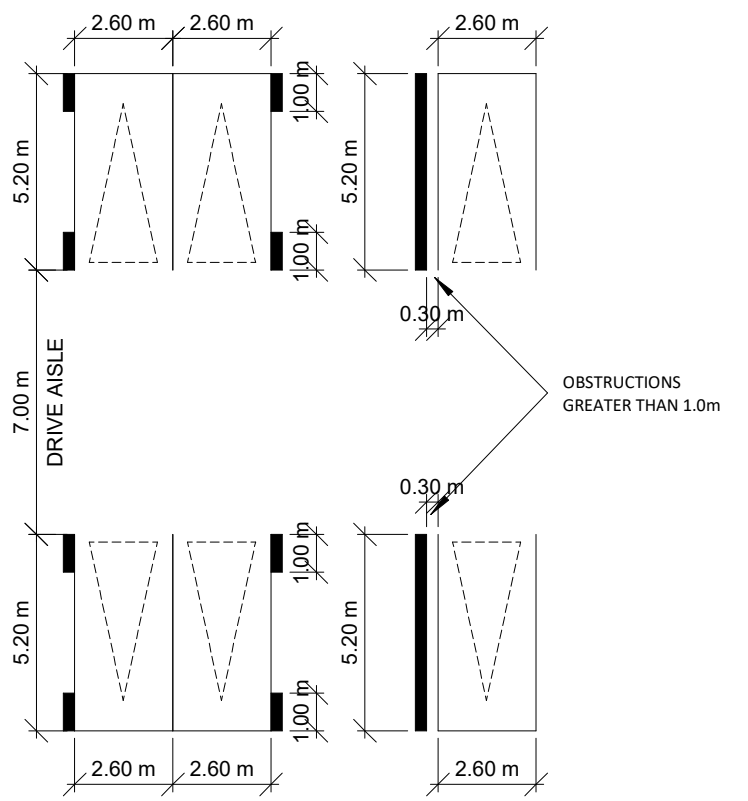

### STANDARD BARRIER-FREE SPACE:

MIN 3.4 x 5.2

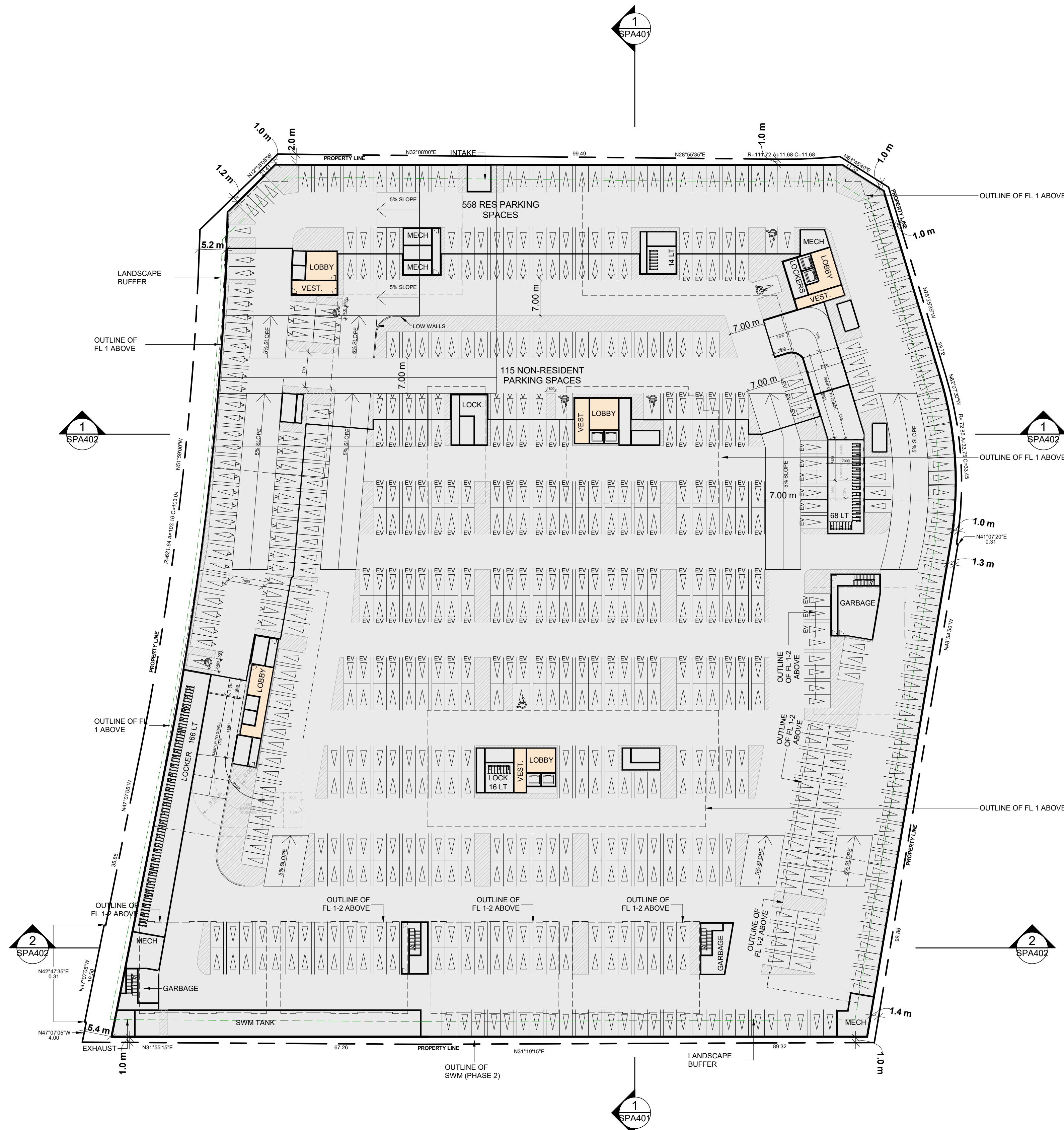
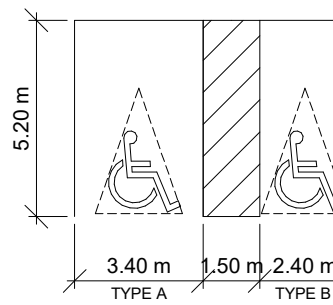

1 SPA102 UNDERGROUND LEVEL 01  
1:500

#	DATE	DESCRIPTION	BY
1	2022-08-22	OFFICIAL PLAN AND ZONING SUBMISSION	AYU

PROJECT  
**4099 Erin Mills Parkway, Mississauga, ON**

DRAWING  
**UNDERGROUND LEVEL 01**

PROJECT NO. 19.001	
PROJECT DATE 2022-08-26	
DRAWN BY JMS	
CHECKED BY AYU	
SCALE As indicated	

DRAWING NO. <b>SPA102</b>	REV <b>1</b>
------------------------------	-----------------