

This drawing, as an instrument of service, is provided by and is the property of Turner Fleischer Architects Inc. The contractor must verify and accept responsibility for all dimensions and conditions on site and must notify Turner Fleischer Architects Inc. of any variations from the supplied information. This drawing is not to be scaled. The architect is not responsible for the accuracy of survey, structural, mechanical, electrical, etc. information shown on this drawing. Refer to the appropriate code and requirements of authorities having jurisdiction. The contractor working from drawings not specifically marked "for Contractor" must assume full responsibility and bear costs for any corrections or damages resulting from his work.

PARKING LEGEND

EV EVSE PARKING

EV-R EV ROUGH-INS

CONVEX MIRROR

STANDARD PARKING DIMENSIONS:

aisle width: MIN 7m

typical parking size:
MIN 2.6 x 5.2

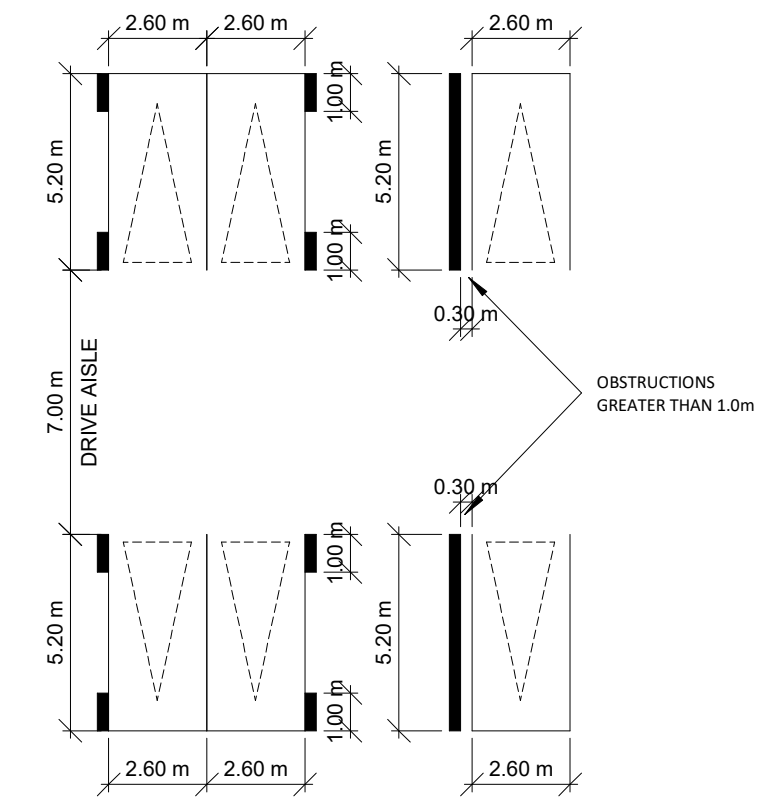

STANDARD BARRIER-FREE SPACE:

MIN 3.4 x 5.2

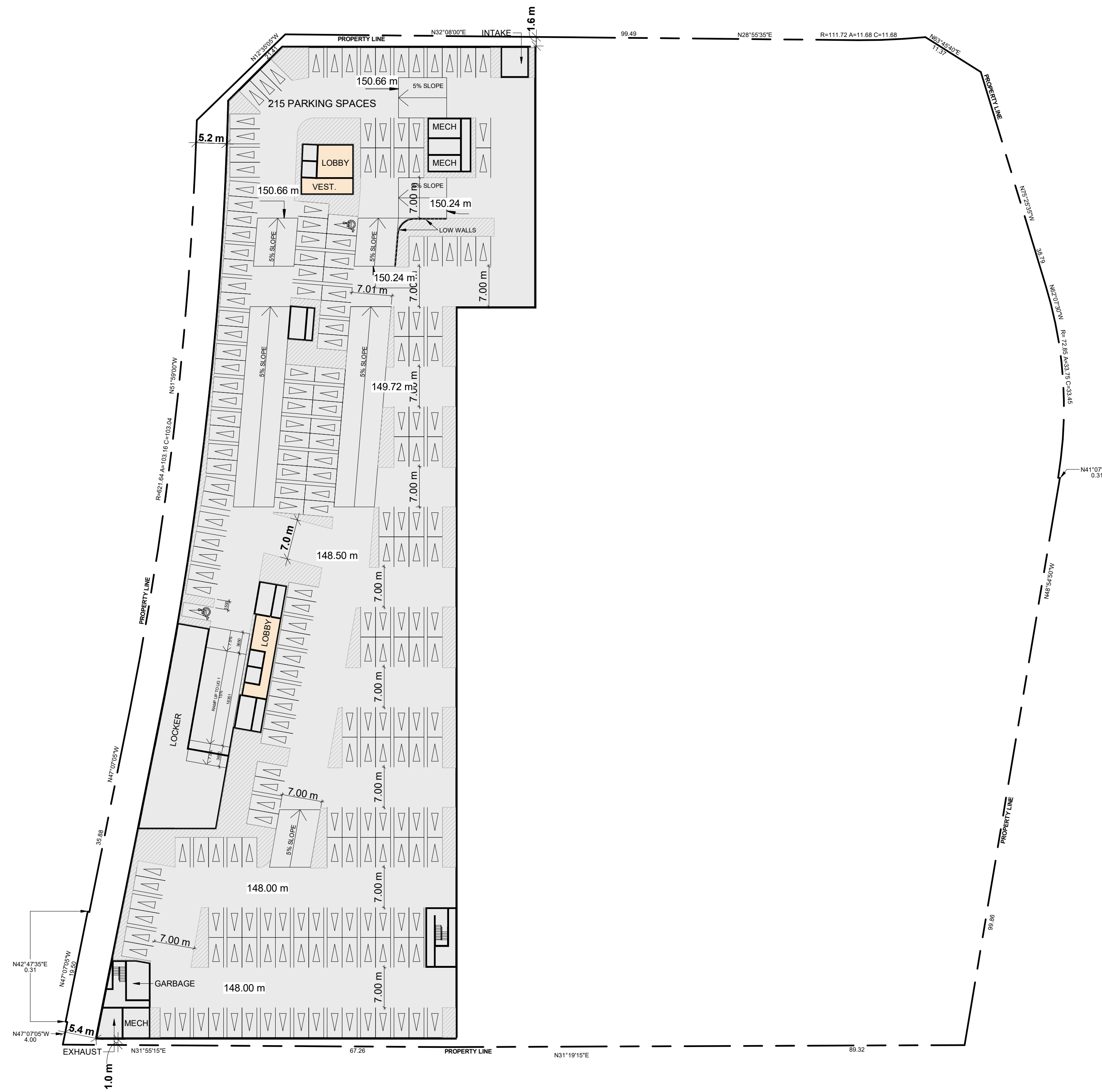
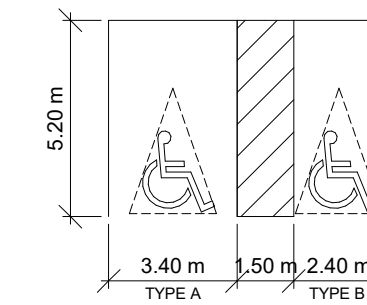

1 UNDERGROUND LEVEL 02
SCALE: 1:500

#	DATE	DESCRIPTION	BY
1	2022-08-22	OFFICIAL PLAN AND ZONING SUBMISSION	AYU

PROJECT
4099 Erin Mills Parkway, Mississauga, ON

DRAWING
UNDERGROUND LEVEL 02

PROJECT NO.
19.001
PROJECT DATE
2022-08-26
DRAWN BY
JMS
CHECKED BY
AYU
SCALE
As indicated



DRAWING NO. **SPA101** REV. **1**

