

# WARD 7- TRAFFIC CALMING PLAN KING STREET EAST

# TRAFFIC CALMING DEVICES

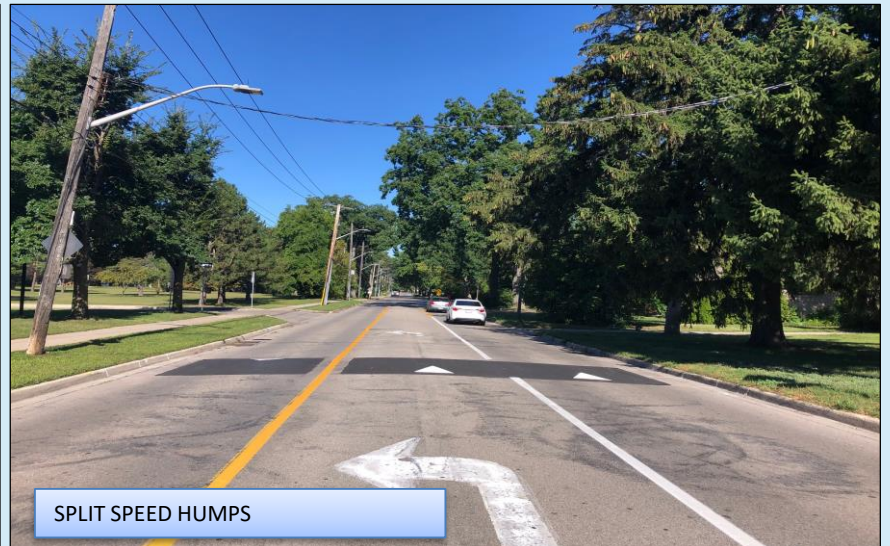

# SPEED CUSHIONS DESIGN

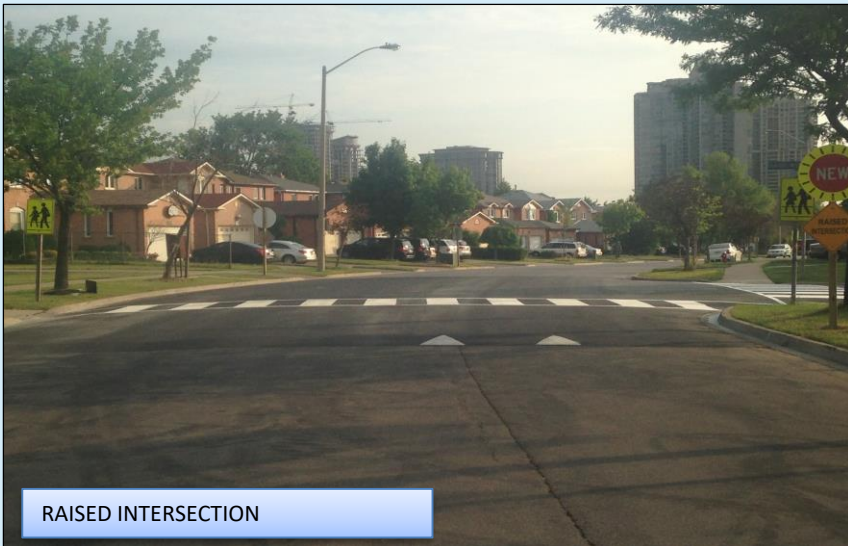
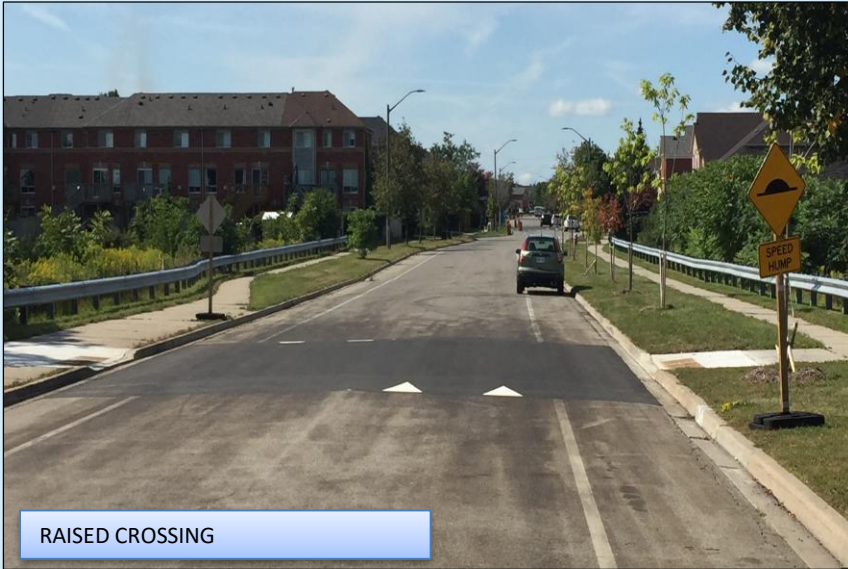
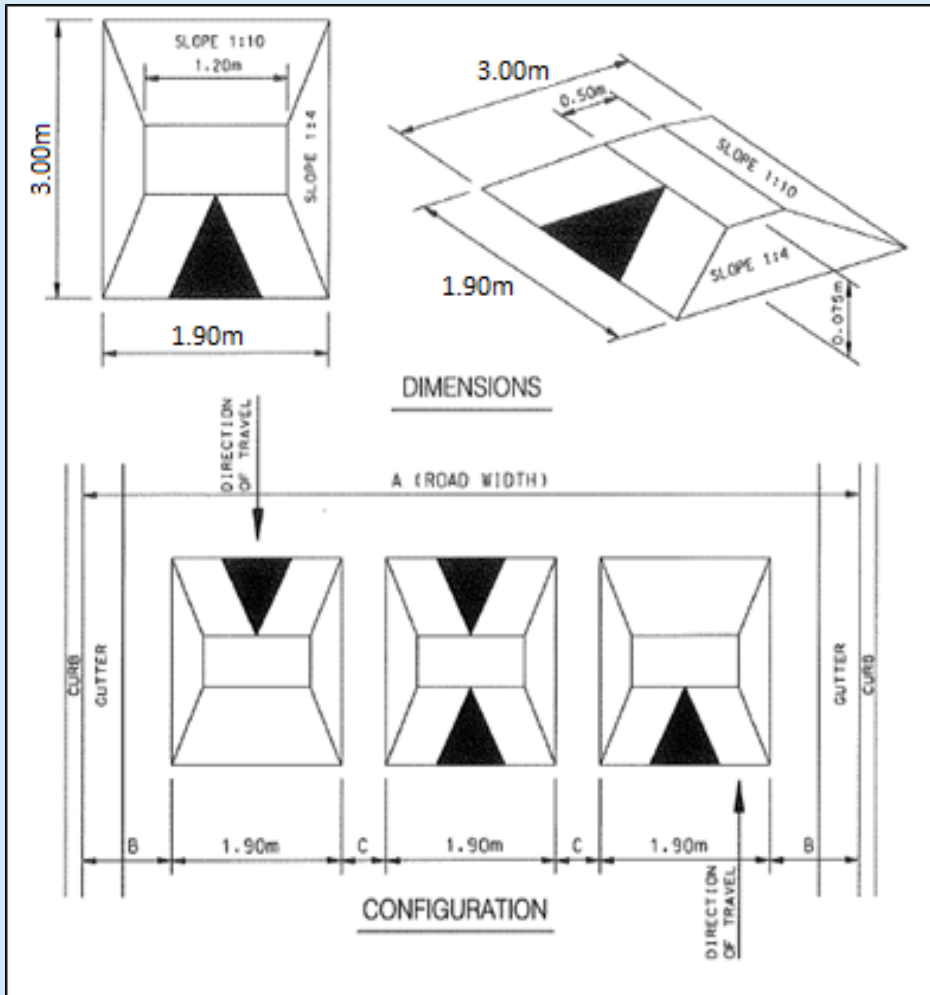

- Raised area on a roadway that does not cover the entire width of the road
- Designed to accommodate wide wheel base of emergency vehicles (easy passage)
- Designed to discourage drivers from travelling at excessive speeds
- A series of speed cushions is more effective than a single installation
- Use on neighborhood roads

# FLEXIBLE BOLLARDS

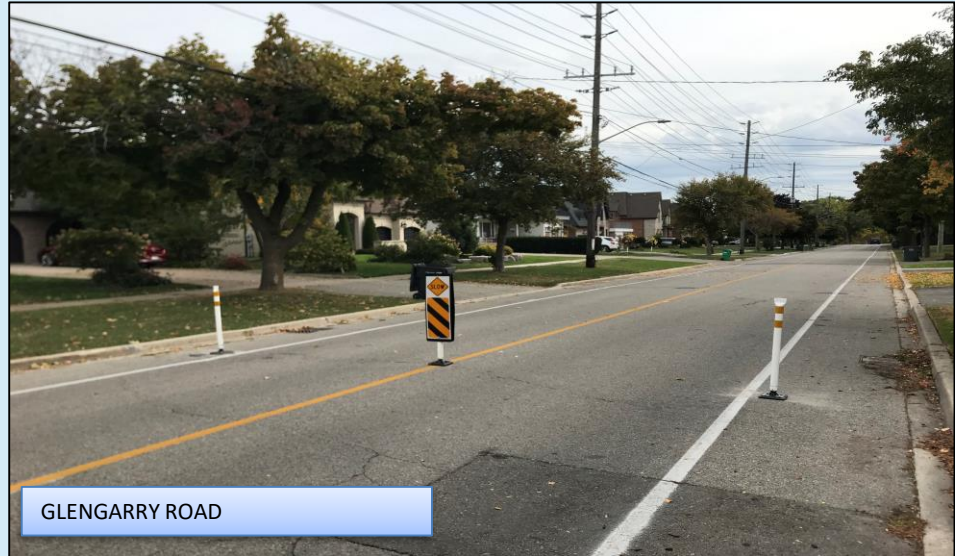

GLENGARRY ROAD



BALSAM AVENUE



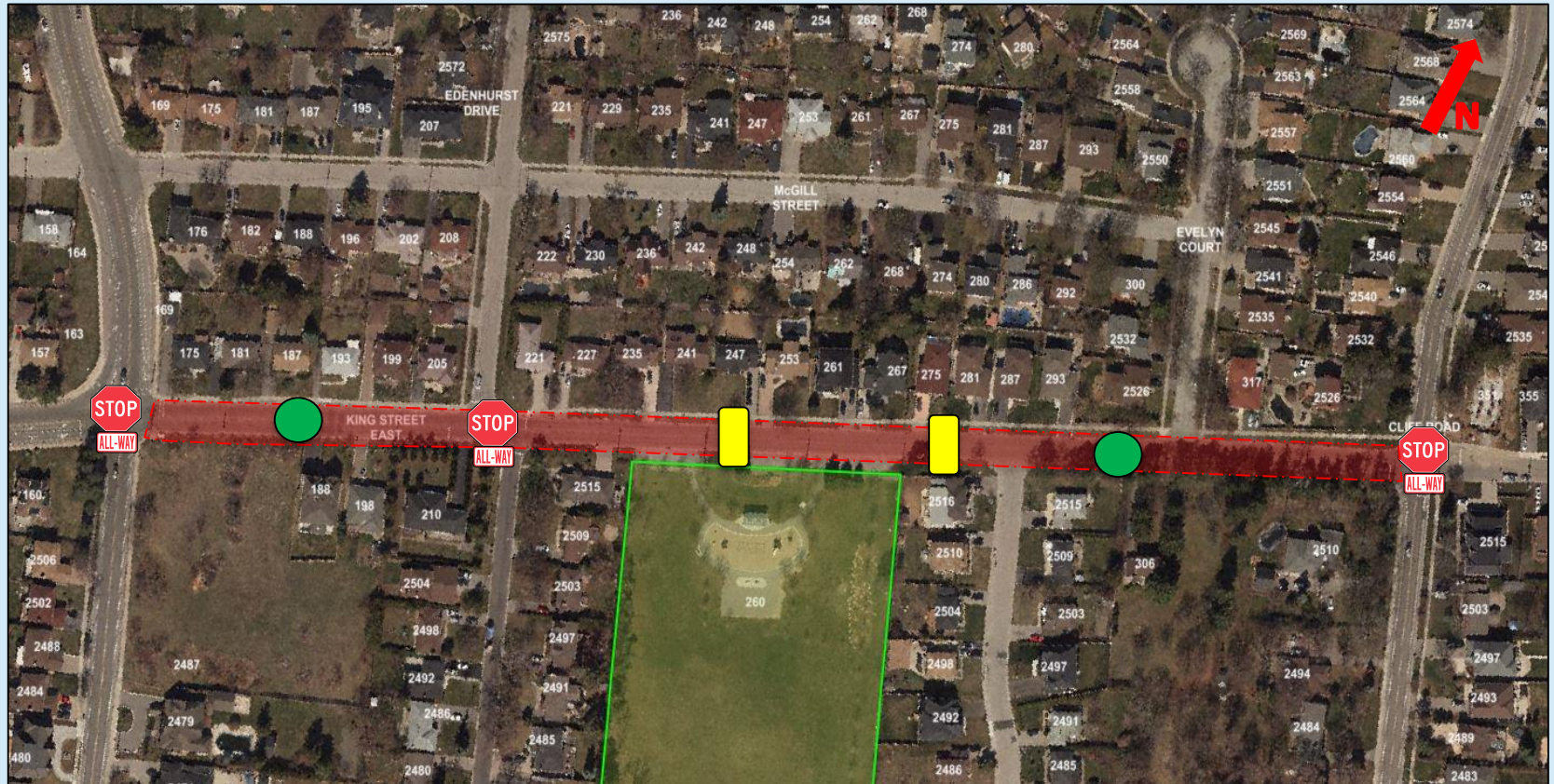

- **Phase 1 (2023)**
  - traffic calming will be installed from Camilla Road to Cliff Road
  - flexible bollards to be installed from Hurontario Street to Camilla Road
- **Phase 2 (planned once watermain repair is completed by Region of Peel)**
  - flexible bollards to be replaced with speed cushions/raised crossing as per original plan

# Camilla Road to Cliff Road



 - Project Area

 - Proposed speed cushion



 - Proposed flexible bollard





- All-Way stop location

# Hurontario Street to Camilla Road



-  - Proposed speed cushion
-  - Proposed raised crossing
-  - Proposed flexible bollard

 - Project Area

 - All-Way stop location