

LEGEND	
---	PROPERTY LINE
---	EXISTING BOARD FENCE
▶	PRIMARY ENTRANCE
▶	SECONDARY ENTRANCE
CB	EXISTING CATCH BASIN
MH	EXISTING MANHOLE
WK	EXISTING WATER KEY
⊕	EXISTING FIRE HYDRANT
○	PROPOSED SANITARY MANHOLE
○	PROPOSED STORM MANHOLE
⊖	PROPOSED CATCH BASIN MANHOLE
⊖	CLOSED SERVICE BOX
⊖	TAPPING SLEEVE & VALVE & BOX
---	EXISTING SANITARY
---	EXISTING WATER
---	EXISTING STORM
---	PROPOSED SANITARY PIPE
---	PROPOSED WATERMAIN PIPE
---	PROPOSED STORM PIPE
SAN	SANITARY SERVICE, 125mmØ TYPICAL
W	WATER SERVICE, 19mmØ TYPICAL
STM	STORM SERVICE, 150mmØ TYPICAL

CLIENT:
 Arjun Kumar / 2182402 Ontario Inc.
 28 Pinewood Trail, Mississauga ON
 tel: (947) 990-4290
 email: Akumar@live.ca

CONSULTANT:
JAIN
 Jain Infrastructure Consultants Ltd.
 7405 EAST DANBRO CRESCENT
 MISSISSAUGA, ON L5N 6P8
 TEL: (905) 285-9900, FAX: (905) 567-5246
 Email: yayub@jainconsultants.com

SEAL:

 Y. YAYUB
 PROFESSIONAL ENGINEER
 LICENSED
 PROVINCE OF ONTARIO
 21-990

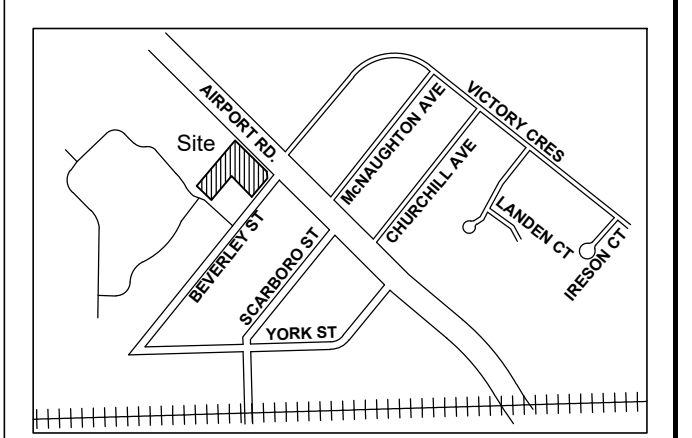
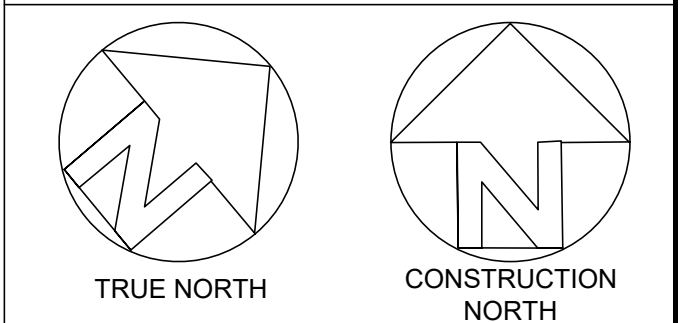

KEY PLAN NTS

Address: 5, 7, 9 Beverley St.

Legal Description: ALL OF LOTS 439, 440 AND 441, REGISTERED PLAN TOR-4 AND PEEL STANDARD CONDOMINIUM PLAN No. 830, CITY OF TORONTO (FORMERLY CITY OF YORK)

Zoning: R3-69

SURVEYOR'S REAL PROPERTY REPORT-PART 1
 PLAN OF SURVEY OF ALL OF LOTS 439, 440 AND 441 REGISTERED PLAN TOR-4 AND PEEL STANDARD CONDOMINIUM PLAN No. 830
 CITY OF MISSISSAUGA REGIONAL MUNICIPALITY OF PEEL

INFORMATION TAKEN FROM A SURVEY PERFORMED BY PEARSON & PEARSON SURVEYING LTD. 2021 (O.L.S.)
 10933 JANE STREET, SECOND FLOOR, MAPLE ONTARIO, L6A 1S1
 (289) 553-5453
 michelepearson@pearsonandpearson.ca

BEARING NOTE
 BEARINGS ARE ASTRONOMIC AND ARE REFERRED TO THE NORTH-WESTERLY LIMIT OF BEVERLEY STREET SHOWN ON SURVEYOR'S REAL PROPERTY REPORT BY RABIEAU & CZERWINSKI, O.L.S., DATED NOVEMBER 18, 2009 AS HAVING A BEARING OF N39°46'00"E.

BENCHMARK
 ELEVATIONS ARE GEODETIC AND ARE REFERRED TO THE CITY OF MISSISSAUGA BENCHMARK.
 BENCHMARK: 172 ELEVATION = 170.722m

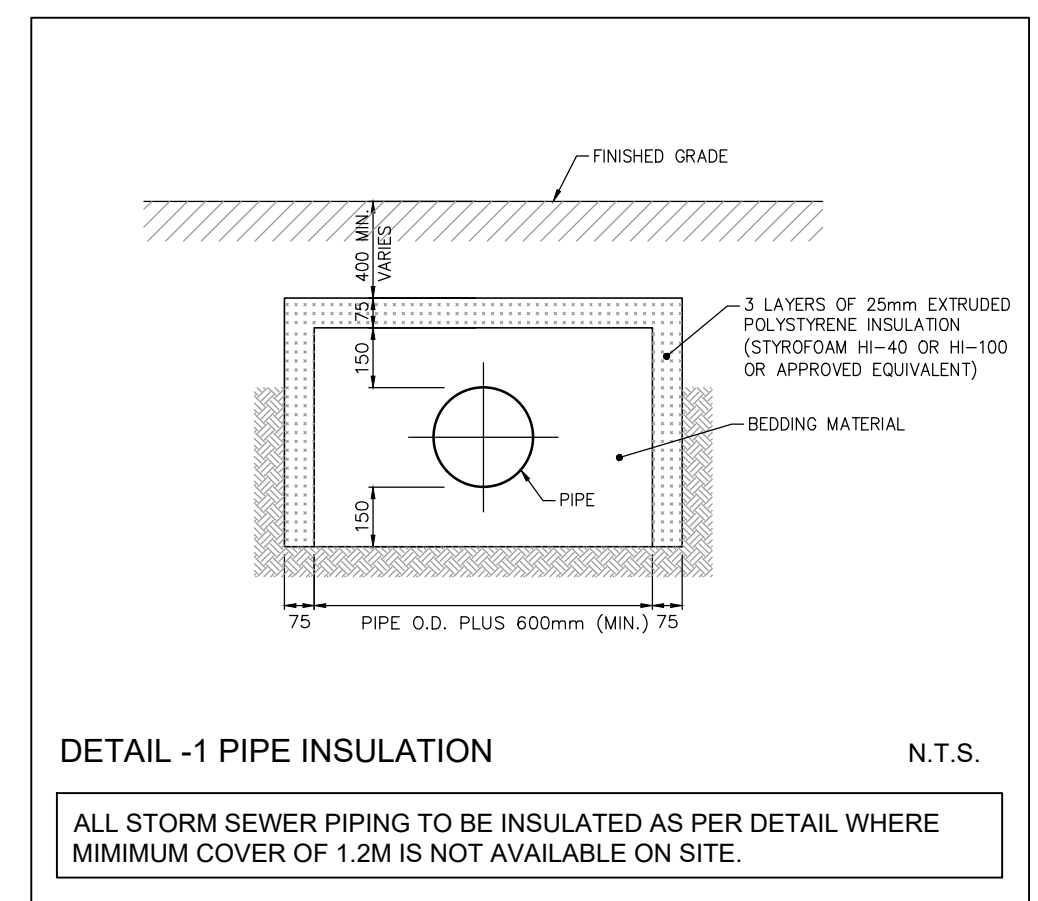

2	ISSUED FOR SITE PLAN APPROVAL	2023/01/23
1	ISSUED FOR SITE PLAN APPROVAL	2022/03/01
No.	Description	Date
PROJECT: 7198-7214 AIRPORT RD Mississauga, ON L4T 1E9		
TITLE: SITE SERVICING PLAN		
PROJECT NO: 21001	DRAWING NO: C101	
CHECKED: Y.A.		