

1 CITY OF MISSISSAUGA - DECIDUOUS TREE PLANTING LP.201

4 POTTED SHRUB BED PLANTING DETAIL LP.201

3 B&B DECIDUOUS TREE PLANTING DETAIL LP.201

5 GROUNDCOVER PLANTING DETAIL LP.201

6 SOIL DEPTH MINIMUMS LP.201

December 15, 2022 3:33 PM I:\PROJECTS\2022\22-105 60 DUNDAS ST EAST - CURRENT PLOT 02 - SPALP-100 PLANTING PLAN\_SPA.DWG

no.	revision	date	by
2	ISSUED FOR ZBA & SPA	2022-12-15	CZ
1	ISSUED FOR ZBA	2022-02-22	CZ

CONTRACTOR MUST VERIFY ALL DIMENSIONS ON THE JOB AND REPORT ANY DISCREPANCY TO THE LANDSCAPE ARCHITECT BEFORE PROCEEDING WITH THE WORK.  
ALL DRAWINGS AND SPECIFICATIONS ARE INSTRUMENTS OF SERVICE AND THE PROPERTY OF THE LANDSCAPE ARCHITECT WHICH MUST BE RETURNED AT THE COMPLETION OF THE WORK.  
ALL DRAWINGS TO BE USED FOR CONSTRUCTION ONLY WHEN SIGNED BY THE LANDSCAPE ARCHITECT.

signed \_\_\_\_\_ date \_\_\_\_\_



20 Champian Blvd. Suite 102 - Toronto ON - M3H 2Z1 info@studiotla.ca www.studiotla.ca



CLIENT  
60 DUNDAS STREET EAST  
MISSISSAUGA, ONTARIO

PROJECT  
PLANTING PLAN

DRAWING  
DRAWN: CZ / JB  
CHECKED: RR  
SCALE: AS SHOWN  
DATE: 2022-01-26  
PROJECT NO: 22-105

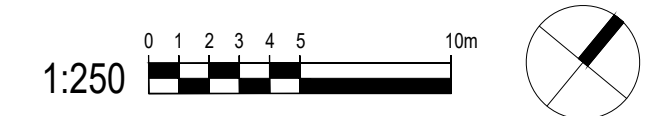

SHEET NO. LP.100

PLANT SCHEDULE						
TREES	CODE	BOTANICAL NAME	COMMON NAME	CONT.	CAL.	REMARKS
	AA2	ACER RUBRUM 'ARMSTRONG'	ARMSTRONG RED MAPLE	B&B	70MM CAL.	NATIVE CULTIVAR
	QC	QUERCUS ROBUR X ALBA 'CRIMSCHMIDT'	CRIMSON SPIRE™ OAK	B&B	70MM CAL.	
DECIDUOUS TREES	CODE	BOTANICAL NAME	COMMON NAME	CONT.	CAL.	REMARKS
	CS	CATALPA SPECIOSA	NORTHERN CATALPA	B&B	70MM CAL.	NATIVE
	CO	CELTIS OCCIDENTALIS	COMMON HACKBERRY	B&B	70MM CAL.	NATIVE
	GP	GINKGO BILOBA 'PRINCETON SENTRY'	PRINCETON SENTRY MAIDENHAIR TREE	B&B	70MM CAL.	
	GS	GLEDITSIA TRIACANTHOS INERMIS 'SKYLINE'	SKYLINE HONEY LOCUST	B&B	70MM CAL.	NATIVE CULTIVAR
	LF	LIRIODENDRON TULPIFERA 'FASTIGIATA'	COLUMNAR TULIP POPLAR	B&B	70MM CAL.	NATIVE CULTIVAR
	ON	OSTRYA VIRGINIANA 'JFS-KW5'	AUTUMN TREASURE® AMERICAN HOPHORNBEAM	B&B	70MM CAL.	NATIVE CULTIVAR
DECIDUOUS SHRUBS	CODE	BOTANICAL NAME	COMMON NAME	CONT.	HT.	REMARKS
	Ac	AMELANCHIER CANADENSIS	CANADIAN SERVICEBERRY	10 GAL.		NATIVE
	Ac2	AMELANCHIER LAEVIS 'CUMULUS'	CUMULUS ALLEGHENY SERVICEBERRY	10 GAL.		NATIVE CULTIVAR
	Ca3	CORNUS ALTERNIFOLIA	PAGODA DOGWOOD	10 GAL.		TREE FORM, NATIVE
	Ca	CORNUS ALTERNIFOLIA 'ARGENTEA'	VARIEGATED PAGODA DOGWOOD	10 GAL.		NATIVE CULTIVAR
	Cw	CORNUS ALTERNIFOLIA 'WSTACKMAN'	GOLDEN SHADOWS® DOGWOOD	10 GAL.		NATIVE CULTIVAR
	CS4	CORNUS KOUSA 'SATOMI'	SATOMI RED KOUSA DOGWOOD	10 GAL.		
	CS5	CORNUS KOUSA 'SUMMER GOLD'	SUMMER GOLD KOUSA DOGWOOD	10 GAL.		
	Hg	HYDRANGEA MACROPHYLLA 'GLOWING EMBERS'	GLOWING EMBERS HYDRANGEA	5 GAL.		
	HI2	HYDRANGEA PANICULATA 'SMNHPK' TM	FIRE LIGHT TIDBIT PANICLE HYDRANGEA	5 GAL.		
GROUND COVERS	CODE	BOTANICAL NAME	COMMON NAME	CONT.		
	AI	ASTER NOVAE-ANGLIAE 'GRAPE CRUSH'	GRAPE CRUSH NEW ENGLAND ASTER	3 GAL.		
	Aa3	ASTILBE X ARENDsii 'AMETHYST'	AMETHYST ASTILBE	3 GAL.		
	ar	ATHYRIUM FILIX-FEMINA	COMMON LADY FERN	2 GAL.		NATIVE
	ck	CALAMAGROSTIS X ACUTIFLORA 'KARL FOERSTER'	KARL FOERSTER FEATHER REED GRASS	3 GAL.		
	co2	CALAMAGROSTIS X ACUTIFLORA 'OVERDAM'	OVERDAM FEATHER REED GRASS	3 GAL.		
	Ca7	CAREX APPALACHICA	APPALACHIAN SEDGE	3 GAL.		NATIVE, DROUGHT TOLERANT
	cp	CAREX PENNSYLVANICA	PENNSYLVANIA SEDGE	3 GAL.		NATIVE
	hy	HEMEROCALLIS X	HYBRID DAYLILY	3 GAL.		
	ha	HOSTA X 'AUTUMN FROST'	AUTUMN FROST HOSTA	3 GAL.		
	ms	MATTEUCCIA STRUTHIOPTERIS	OSTRICH FERN	2 GAL.		NATIVE
	Sg	SPIRAEA JAPONICA 'GOLDFLAME'	GOLDFLAME JAPANESE SPIREA	3 GAL.		

2	ISSUED FOR ZBA & SPA	2022-12-15	CZ
1	ISSUED FOR ZBA	2022-02-22	CZ
no.	revision	date	by

CONTRACTOR MUST VERIFY ALL DIMENSIONS ON THE JOB AND REPORT ANY DISCREPANCY TO THE LANDSCAPE ARCHITECT BEFORE PROCEEDING WITH THE WORK.  
 ALL DRAWINGS AND SPECIFICATIONS ARE INSTRUMENTS OF SERVICE AND THE PROPERTY OF THE LANDSCAPE ARCHITECT WHICH MUST BE RETURNED AT THE COMPLETION OF THE WORK.  
 ALL DRAWINGS TO BE USED FOR CONSTRUCTION ONLY WHEN SIGNED BY THE LANDSCAPE ARCHITECT.

signed \_\_\_\_\_ date \_\_\_\_\_



20 Champian Blvd. Suite 102 - Toronto ON - M3H 2Z1 info@studiotla.ca www.studiotla.ca



CLIENT  
 60 DUNDAS STREET EAST

MISSISSAUGA, ONTARIO

PROJECT  
 PLANTING SCHEDULE

DRAWING  
 DRAWN: CZ / JB  
 CHECKED: RR  
 SCALE: AS SHOWN  
 DATE: 2022-01-26  
 PROJECT NO.: 22-105



SHEET NO.: LP.101

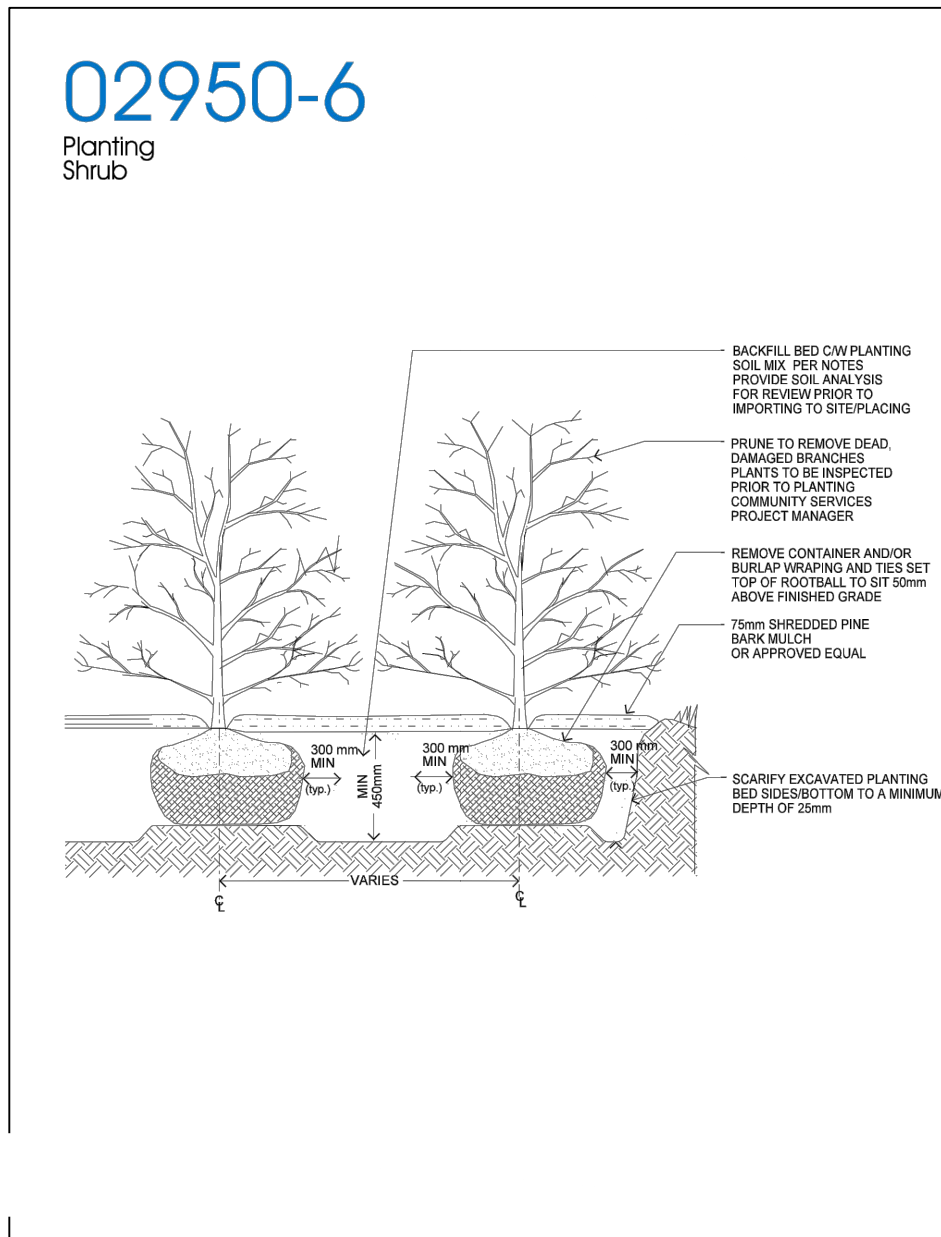
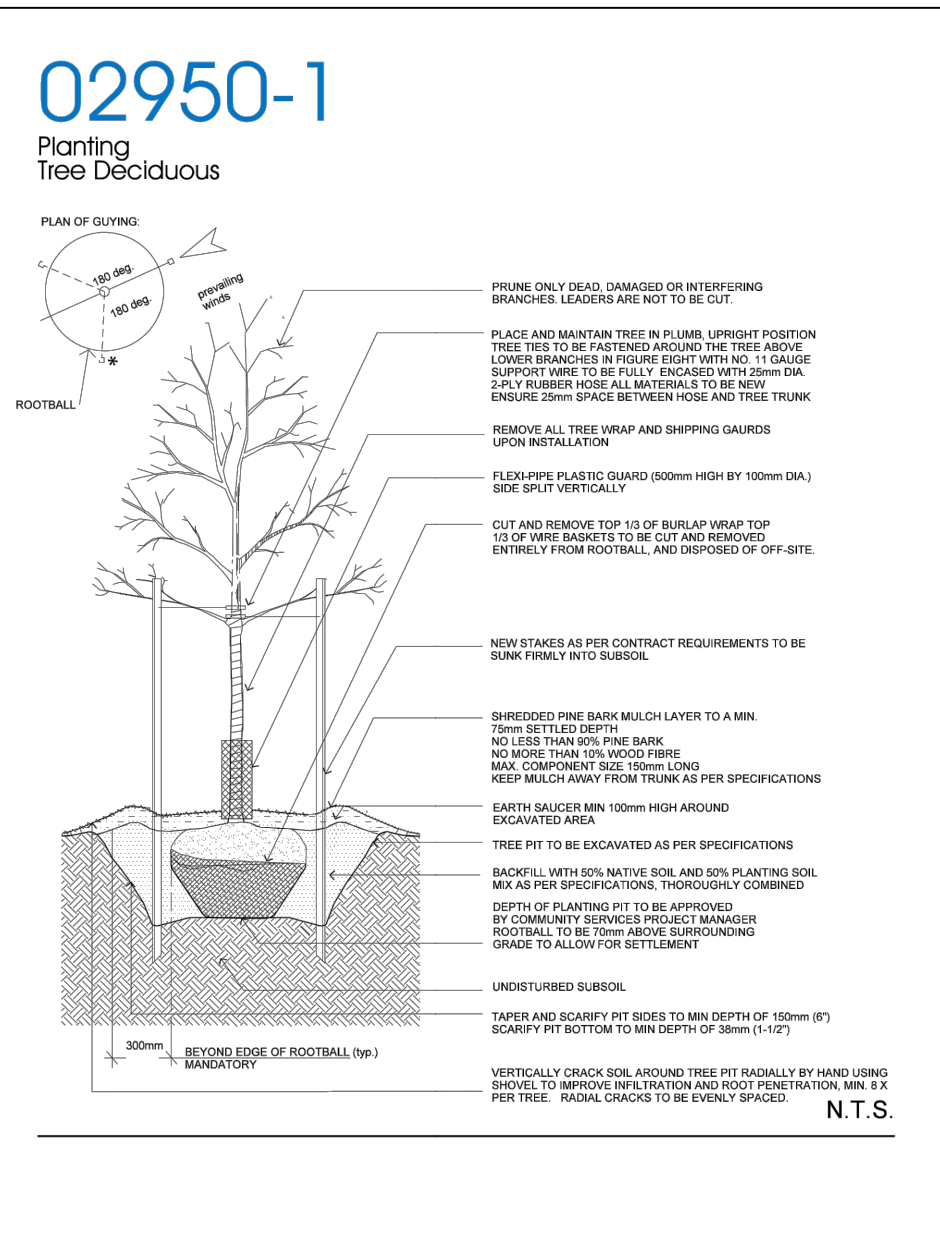

1 CITY OF MISSISSAUGA - DECIDUOUS TREE PLANTING  
N.T.S.

2 CITY OF MISSISSAUGA - SHRUB PLANTING  
SCALE=1:1

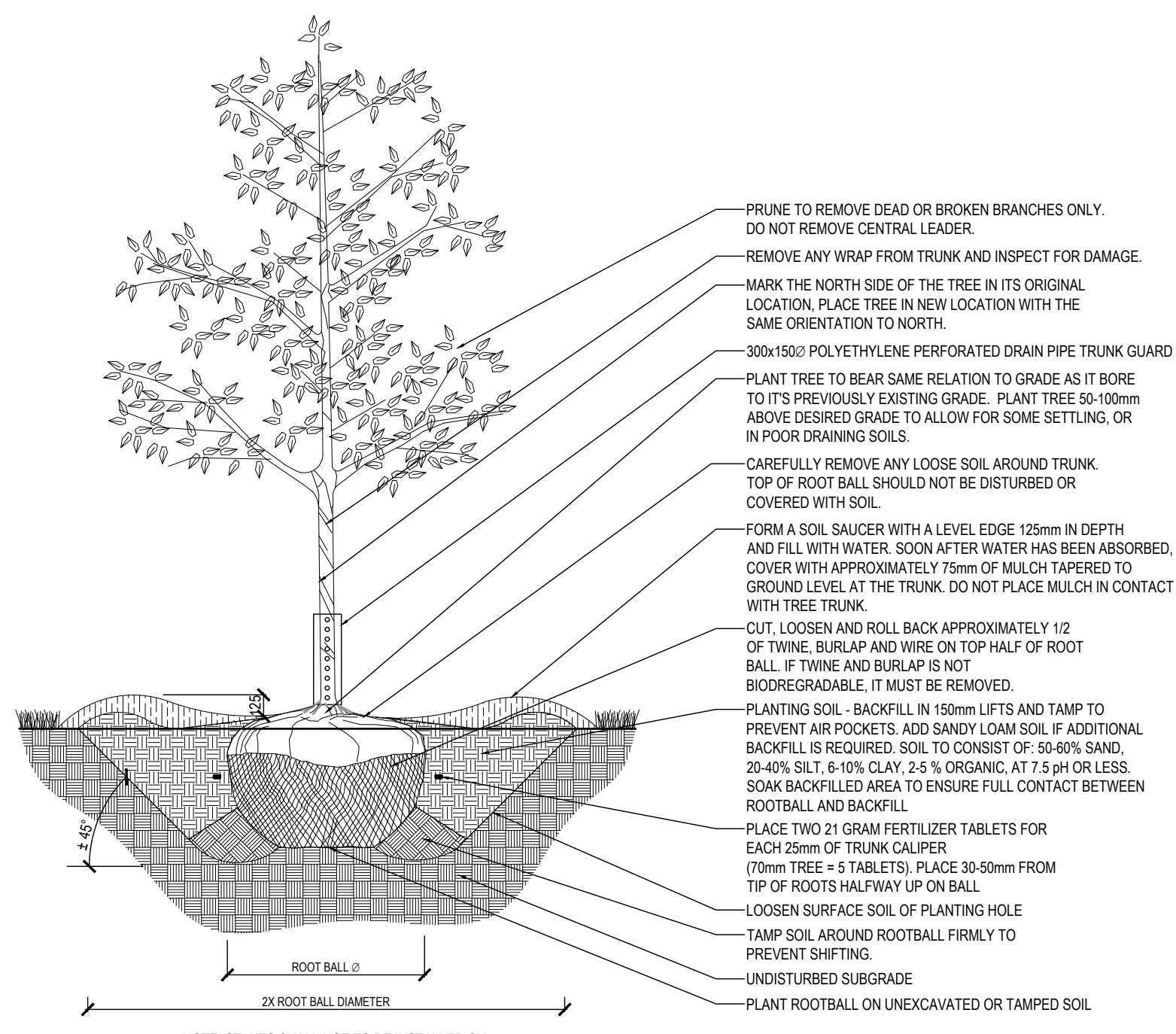

3 B&B DECIDUOUS TREE PLANTING DETAIL  
NO SCALE

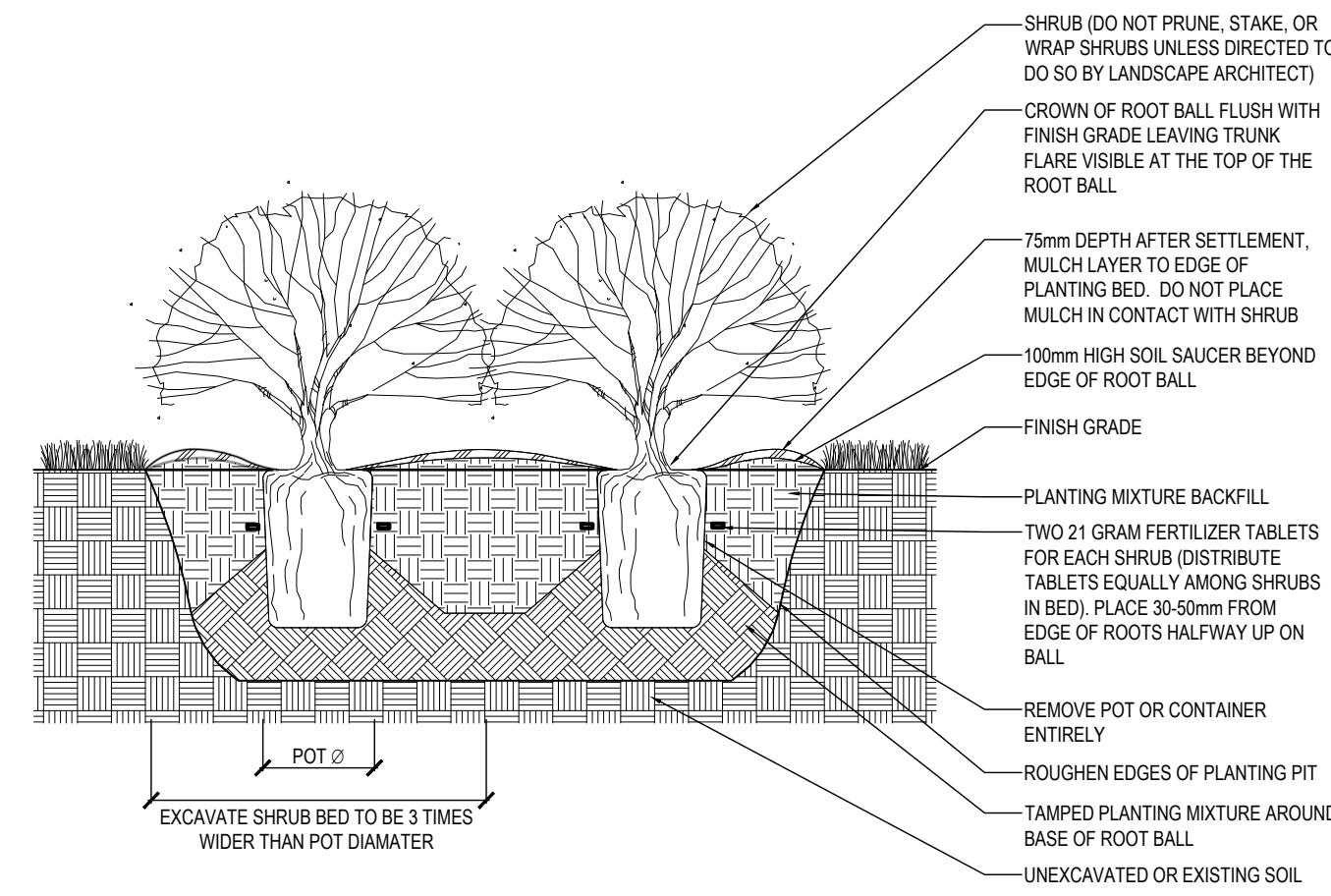

4 POTTED SHRUB BED PLANTING DETAIL  
NO SCALE

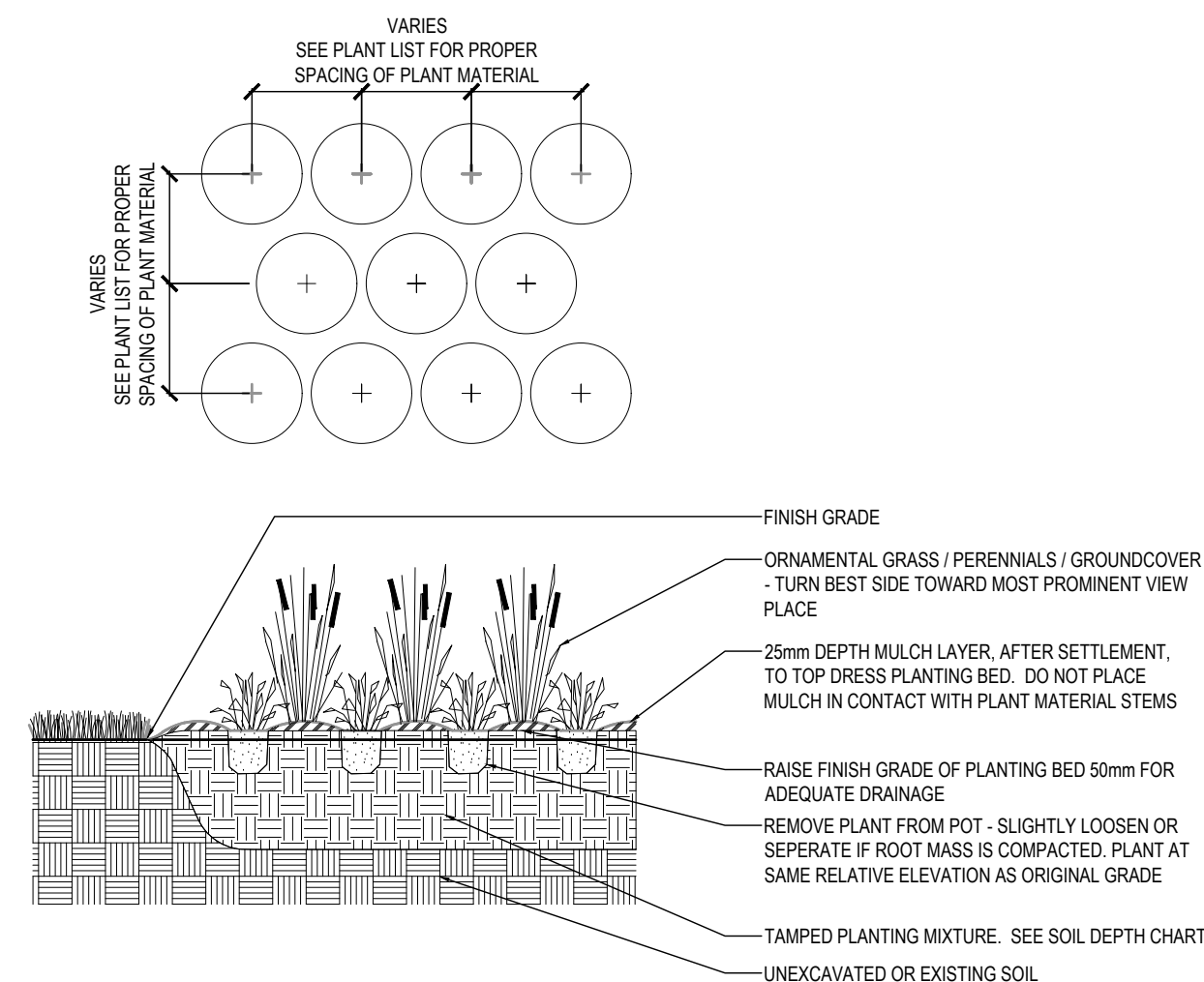

5 GROUND COVER PLANTING DETAIL  
NO SCALE

NOTE: THE CONTRACTOR IS TO SUPPLY TOPSOIL FILL MATERIAL TO THE DEPTHS INDICATED ON THE CHART BELOW.

LANDSCAPE AREAS	DEPTH IN mm
LAWN AREAS (SCD)	150
LAWN AREAS (SEED)	150
PLANTING BEDS - GRASSES, PERENNIALS AND GROUND COVER	300
PLANTING BEDS - MEDIUM AND SMALL SHRUBS	450
RAISED PLANTERS	600
SHADE AND ORNAMENTAL TREES	PER TREE INSTALLATION DETAIL
ON SLAB SHRUB PLANTING	600 WITH 150mm DRAINAGE GRAVEL

6 SOIL DEPTH MINIMUMS  
NO SCALE

no.	revision	date	by
2	ISSUED FOR ZBA & SPA	2022-12-15	CZ
1	ISSUED FOR ZBA	2022-02-22	CZ

CONTRACTOR MUST VERIFY ALL DIMENSIONS ON THE JOB AND REPORT ANY DISCREPANCY TO THE LANDSCAPE ARCHITECT BEFORE PROCEEDING WITH THE WORK.

ALL DRAWINGS AND SPECIFICATIONS ARE INSTRUMENTS OF SERVICE AND THE PROPERTY OF THE LANDSCAPE ARCHITECT WHICH MUST BE RETURNED AT THE COMPLETION OF THE WORK.

ALL DRAWINGS TO BE USED FOR CONSTRUCTION ONLY WHEN SIGNED BY THE LANDSCAPE ARCHITECT.

signed \_\_\_\_\_ date \_\_\_\_\_

**STUDIO tla**

20 Champian Blvd. Suite 102 - Toronto ON - M3H 2Z1 info@studiotla.ca www.studiotla.ca

**almeqa**

CLIENT  
60 DUNDAS STREET EAST  
MISSISSAUGA, ONTARIO

PROJECT  
PLANTING DETAILS





DRAWING  
DRAWN: CZ / JB  
CHECKED: RR  
SCALE: AS SHOWN  
DATE: 2022-01-26  
PROJECT NO: 22-105

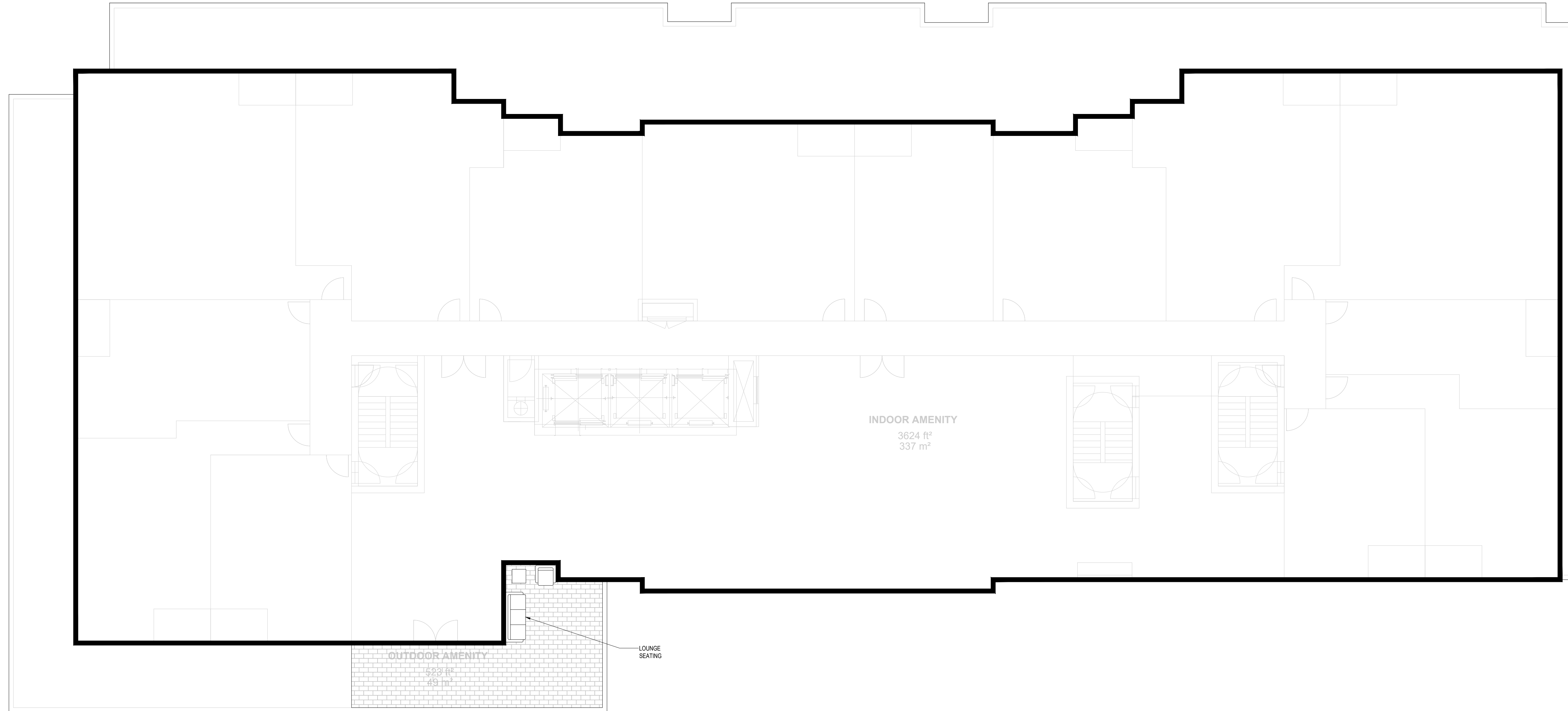

SHEET NO. LP.201

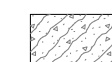
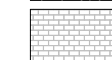

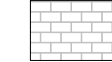
LEGEND

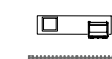
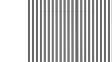
-  ORNAMENTAL GRASS/ PERENNIALS
-  UNIT PAVER 1 SRI >29
-  UNIT PAVER 2 SRI >29
-  UNIT PAVER 3 SRI >29
-  SITE FURNITURE
-  BBQ STATION
-  PERGOLA

no.	revision	date	by
2	ISSUED FOR ZBA & SPA	2022-12-15	CZ
1	ISSUED FOR ZBA	2022-02-22	CZ

no.	revision	date	by
2	ISSUED FOR ZBA & SPA	2022-12-15	CZ
1	ISSUED FOR ZBA	2022-02-22	CZ

CONTRACTOR MUST VERIFY ALL DIMENSIONS ON THE JOB AND REPORT ANY DISCREPANCY TO THE LANDSCAPE ARCHITECT BEFORE PROCEEDING WITH THE WORK.  
 ALL DRAWINGS AND SPECIFICATIONS ARE INSTRUMENTS OF SERVICE AND THE PROPERTY OF THE LANDSCAPE ARCHITECT WHICH MUST BE RETURNED AT THE COMPLETION OF THE WORK.  
 ALL DRAWINGS TO BE USED FOR CONSTRUCTION ONLY WHEN SIGNED BY THE LANDSCAPE ARCHITECT.

signed \_\_\_\_\_ date \_\_\_\_\_



20 Champian Blvd. Suite 102 - Toronto ON - M3H 2Z1 info@studiotla.ca www.studiotla.ca



CLIENT  
 60 DUNDUS STREET EAST

MISSISSAUGA, ONTARIO

PROJECT  
 3RD FLOOR AMENITY PLAN





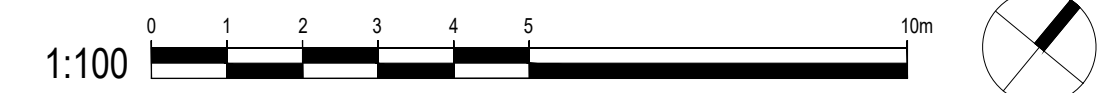

DRAWING  
 DRAWN: CZ / JB  
 CHECKED: RR  
 SCALE: AS SHOWN  
 DATE: 2022-01-26  
 PROJECT NO: 22-105

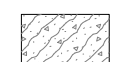
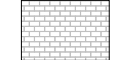

SHEET NO. LR.100



LEGEND

-  ORNAMENTAL GRASS/ PERENNIALS
-  UNIT PAVER 1 SRI >29
-  UNIT PAVER 2 SRI >29
-  UNIT PAVER 3 SRI >29
-  SITE FURNITURE
-  BBQ STATION
-  PERGOLA

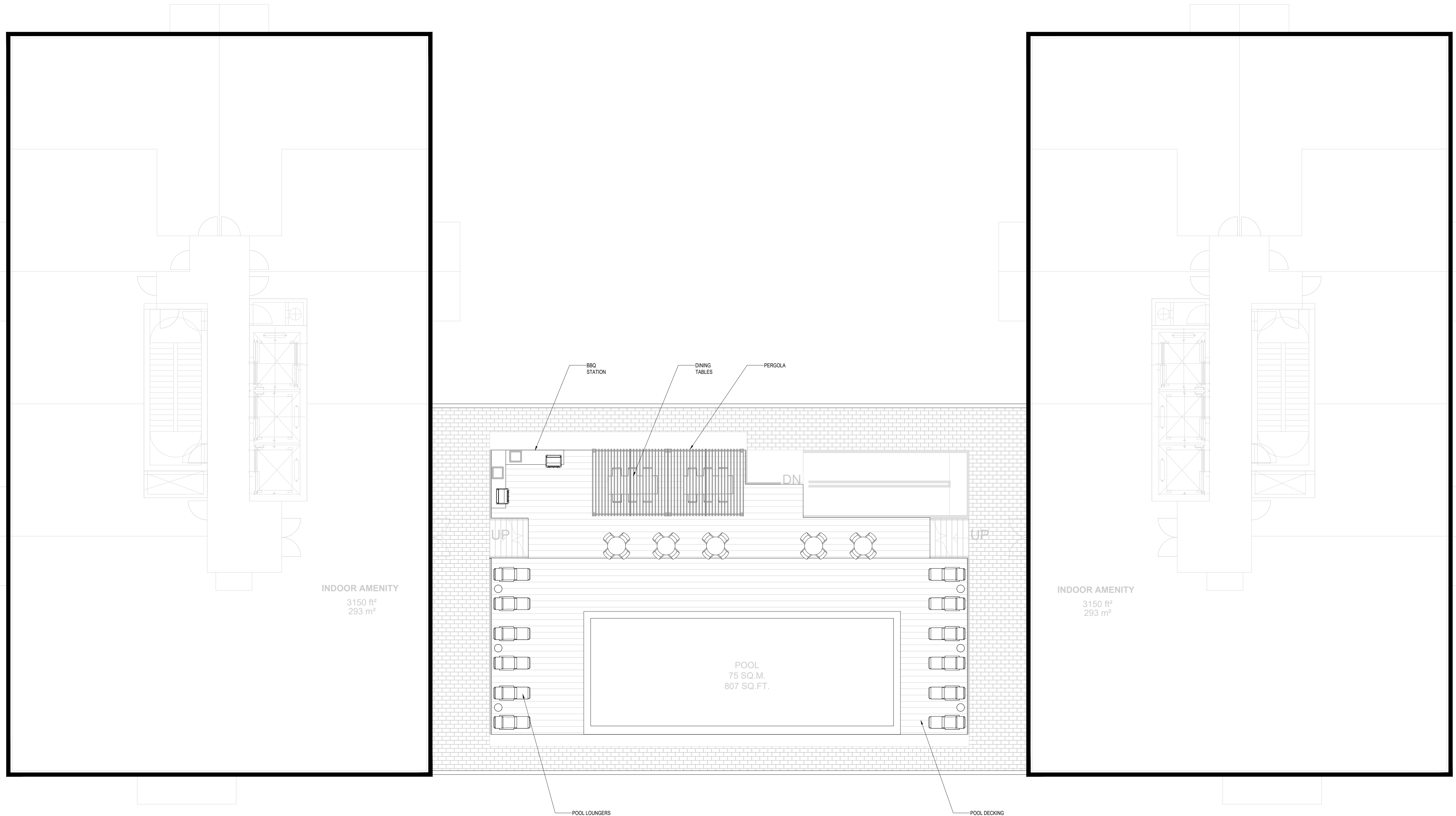

no.	revision	date	by
2	ISSUED FOR ZBA & SPA	2022-12-15	CZ
1	ISSUED FOR ZBA	2022-02-22	CZ

CONTRACTOR MUST VERIFY ALL DIMENSIONS ON THE JOB AND REPORT ANY DISCREPANCY TO THE LANDSCAPE ARCHITECT BEFORE PROCEEDING WITH THE WORK.  
 ALL DRAWINGS AND SPECIFICATIONS ARE INSTRUMENTS OF SERVICE AND THE PROPERTY OF THE LANDSCAPE ARCHITECT WHICH MUST BE RETURNED AT THE COMPLETION OF THE WORK.  
 ALL DRAWINGS TO BE USED FOR CONSTRUCTION ONLY WHEN SIGNED BY THE LANDSCAPE ARCHITECT.

signed \_\_\_\_\_ date \_\_\_\_\_



20 Champian Blvd. Suite 102 - Toronto ON - M3H 2Z1 info@studiotla.ca www.studiotla.ca



CLIENT  
 60 DUNDUS STREET EAST  
 MISSISSAUGA, ONTARIO

PROJECT  
 14TH FLOOR AMENITY PLAN

DRAWING  
 DRAWN: CZ / JB  
 CHECKED: RR  
 SCALE: AS SHOWN  
 DATE: 2022-01-26  
 PROJECT NO.: 22-105





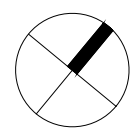
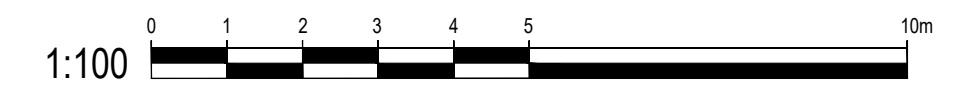

SHEET NO.: LR.101

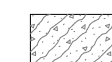
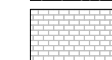

**NOT FOR CONSTRUCTION**

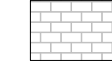
**LEGEND**

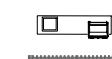
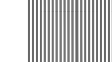
-  ORNAMENTAL GRASS/PERENNIALS
-  UNIT PAVER 1 SRI >29
-  UNIT PAVER 2 SRI >29
-  UNIT PAVER 3 SRI >29
-  SITE FURNITURE
-  BBQ STATION
-  PERGOLA

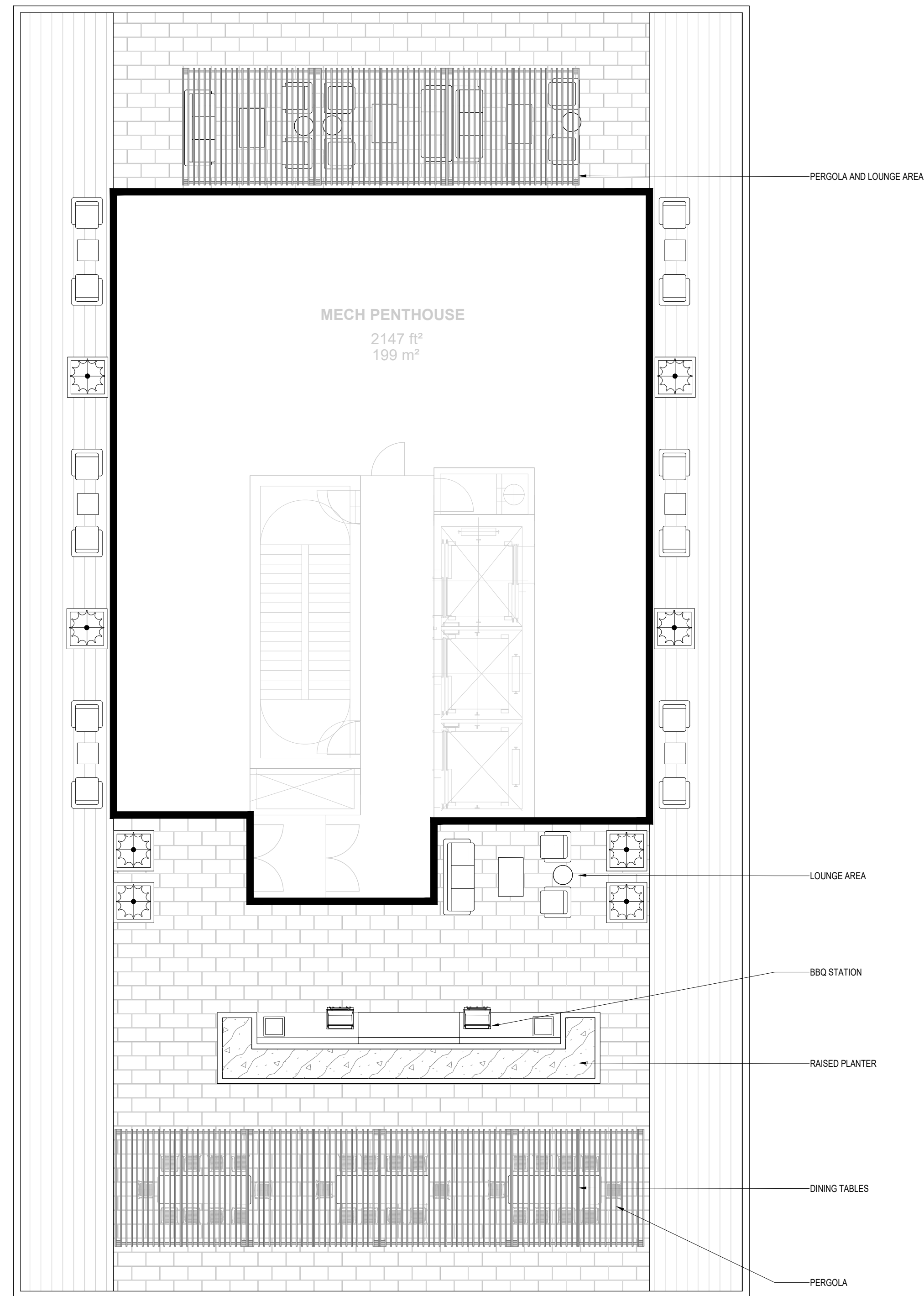

no.	revision	date	by
2	ISSUED FOR ZBA & SPA	2022-12-15	CZ
1	ISSUED FOR ZBA	2022-02-22	CZ

CONTRACTOR MUST VERIFY ALL DIMENSIONS ON THE JOB AND REPORT ANY DISCREPANCY TO THE LANDSCAPE ARCHITECT BEFORE PROCEEDING WITH THE WORK. ALL DRAWINGS AND SPECIFICATIONS ARE INSTRUMENTS OF SERVICE AND THE PROPERTY OF THE LANDSCAPE ARCHITECT WHICH MUST BE RETURNED AT THE COMPLETION OF THE WORK. ALL DRAWINGS TO BE USED FOR CONSTRUCTION ONLY WHEN SIGNED BY THE LANDSCAPE ARCHITECT.

signed \_\_\_\_\_ date \_\_\_\_\_



20 Champian Blvd. Suite 102 - Toronto ON - M3H 2Z1 info@studiotla.ca www.studiotla.ca



CLIENT  
60 DUNDUS STREET EAST  
MISSISSAUGA, ONTARIO

PROJECT  
28TH FLOOR AMENITY PLAN

DRAWING  
DRAWN: CZ / JB  
CHECKED: RR  
SCALE: AS SHOWN  
DATE: 2022-01-26  
PROJECT NO.: 22-105

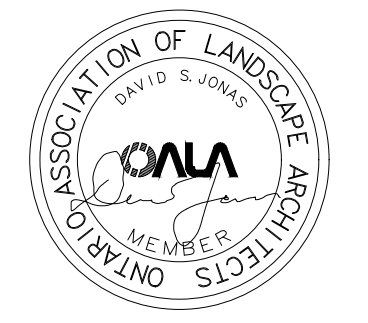

SHEET NO.: LR.102

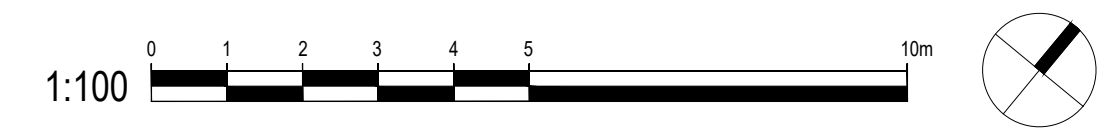

December 15, 2022 3:33 PM I:\PROJECTS\2022\22-105 60 DUNDAS ST EAST\CURRENT\PILOT\02-SPA\LR.102 AMENITY PLAN\_SPA.DWG

LEGEND

- CONCRETE PAVING SRP-29
- UNIT PAVING TYP.A SRP-29
- UNIT PAVING TYP.B SRP-29
- GRAVEL
- TREE PROTECTION FENCE
- 1.8M HT. DECORATIVE METAL FENCE
- 1.8M HT. WOOD PRIVACY SCREEN
- 1.2M HT. CHAIN-LINK FENCE
- 1.2M HT. DECORATIVE FENCE & GATE
- BIKE PARKING
- BENCH
- SOIL CELL AREA
- LIGHT STANDARDS
- LIGHT BOLLARD
- EXISTING TREE TO REMAIN

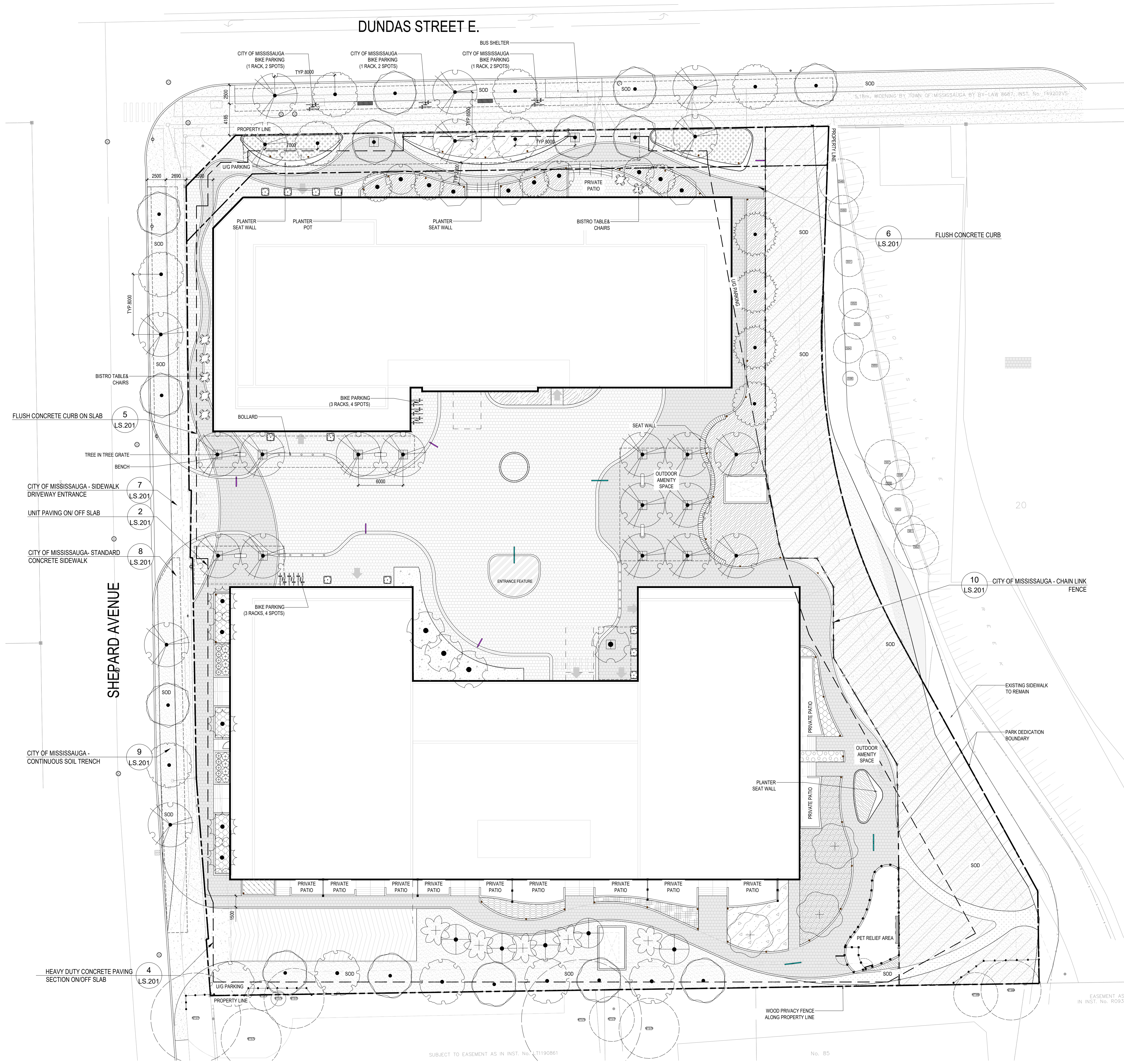

December 15, 2022 3:34 PM I:\PROJECTS\2022\22-105 60 DUNDAS ST EAST\CURRENT\PILOT\02-SPALLS-100 LANDSCAPE PLAN\_SPA.DWG

SUBJECT TO EASEMENT AS IN INST. No. 31190861

No. 85

EASEMENT AS IN INST. No. R0934



no.	revision	date	by
2	ISSUED FOR ZBA & SPA	2022-12-15	CZ
1	ISSUED FOR ZBA	2022-02-22	CZ

CONTRACTOR MUST VERIFY ALL DIMENSIONS ON THE JOB AND REPORT ANY DISCREPANCY TO THE LANDSCAPE ARCHITECT BEFORE PROCEEDING WITH THE WORK.  
 ALL DRAWINGS AND SPECIFICATIONS ARE INSTRUMENTS OF SERVICE AND THE PROPERTY OF THE LANDSCAPE ARCHITECT WHICH MUST BE RETURNED AT THE COMPLETION OF THE WORK.  
 ALL DRAWINGS TO BE USED FOR CONSTRUCTION ONLY WHEN SIGNED BY THE LANDSCAPE ARCHITECT.

signed \_\_\_\_\_ date \_\_\_\_\_



20 Champian Blvd. Suite 102 - Toronto ON - M3H 2Z1 info@studiotla.ca www.studiotla.ca



CLIENT  
60 DUNDAS STREET EAST

PROJECT  
MISSISSAUGA, ONTARIO

LANDSCAPE PLAN

DRAWING  
DRAWN: CZ / JB  
CHECKED: RR  
SCALE: AS SHOWN  
DATE: 2022-01-26  
PROJECT NO.: 22-105



SHEET NO.: LS.100

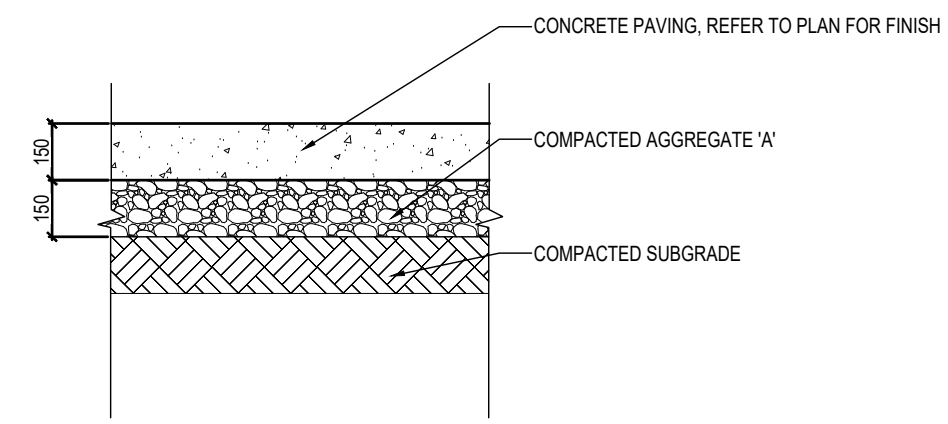

1 PEDESTRIAN CONCRETE PAVING ON GRADE  
SCALE=1:20

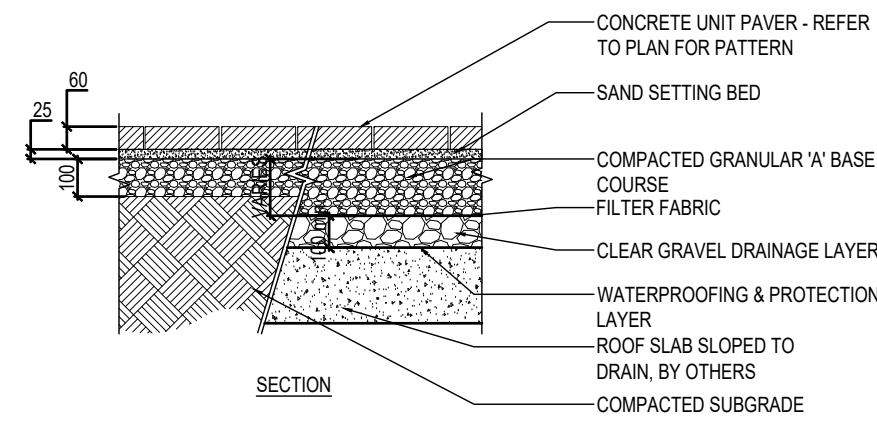

2 UNIT PAVING ON/ OFF SLAB  
SCALE=1:20

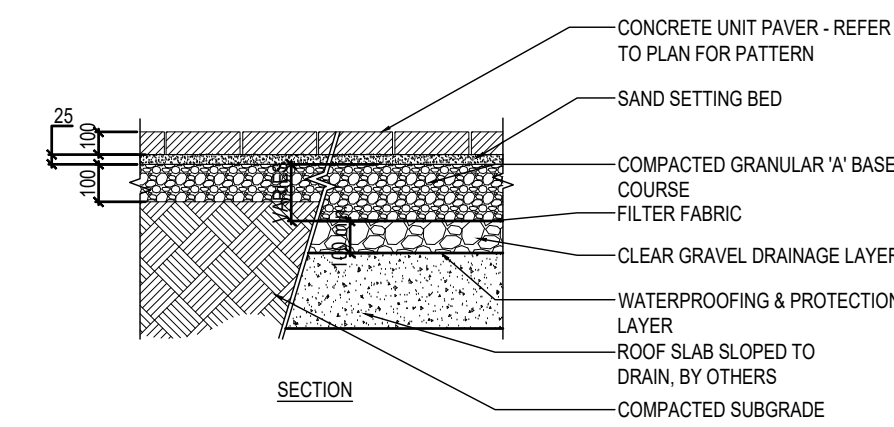

3 HD UNIT PAVING ON/OFF SLAB  
SCALE=1:20

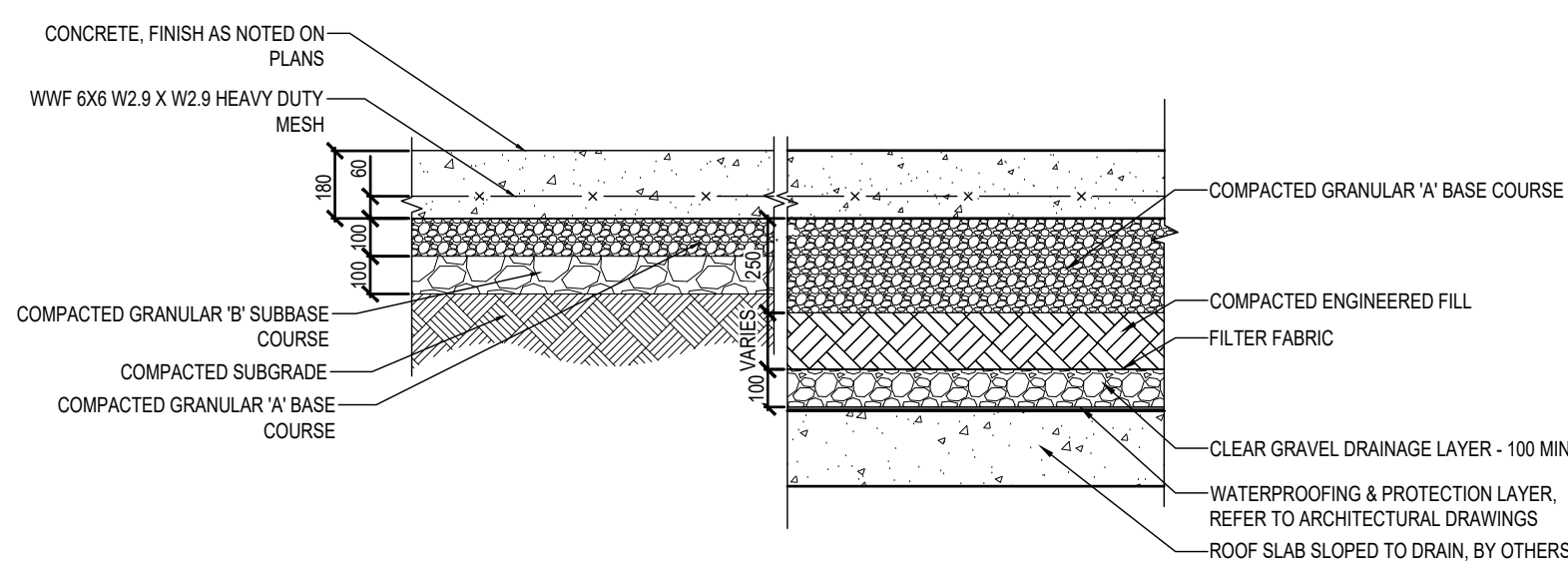

4 HEAVY DUTY CONCRETE PAVING SECTION ON/OFF SLAB  
SCALE=1:20

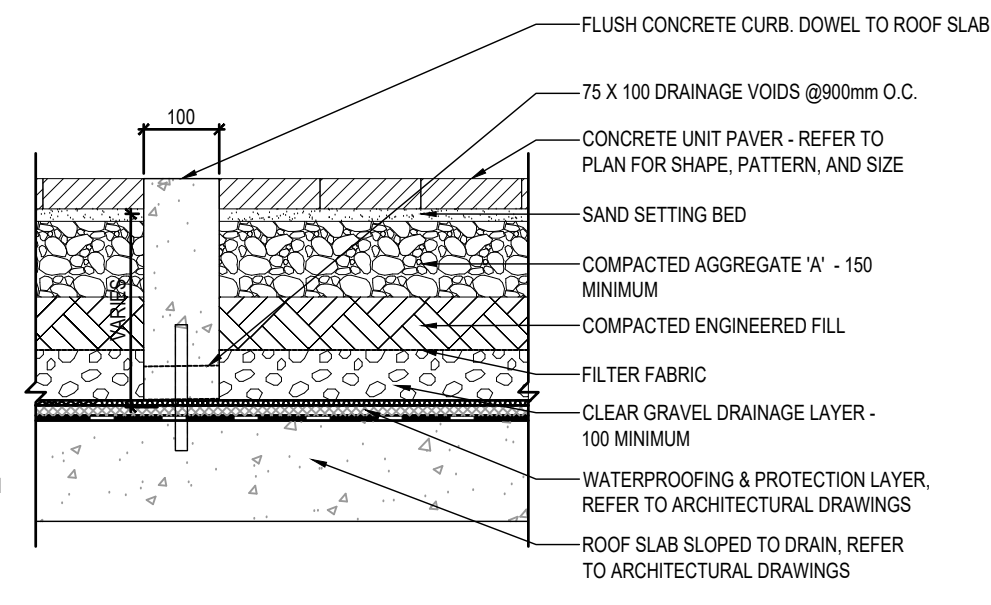

5 FLUSH CONCRETE CURB ON SLAB  
SCALE=1:15

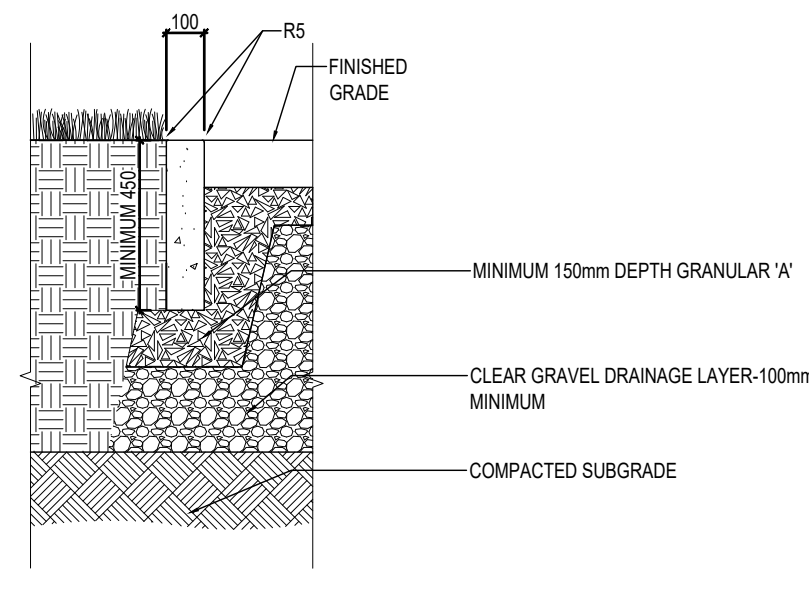

6 FLUSH CONCRETE CURB  
SCALE=1:20

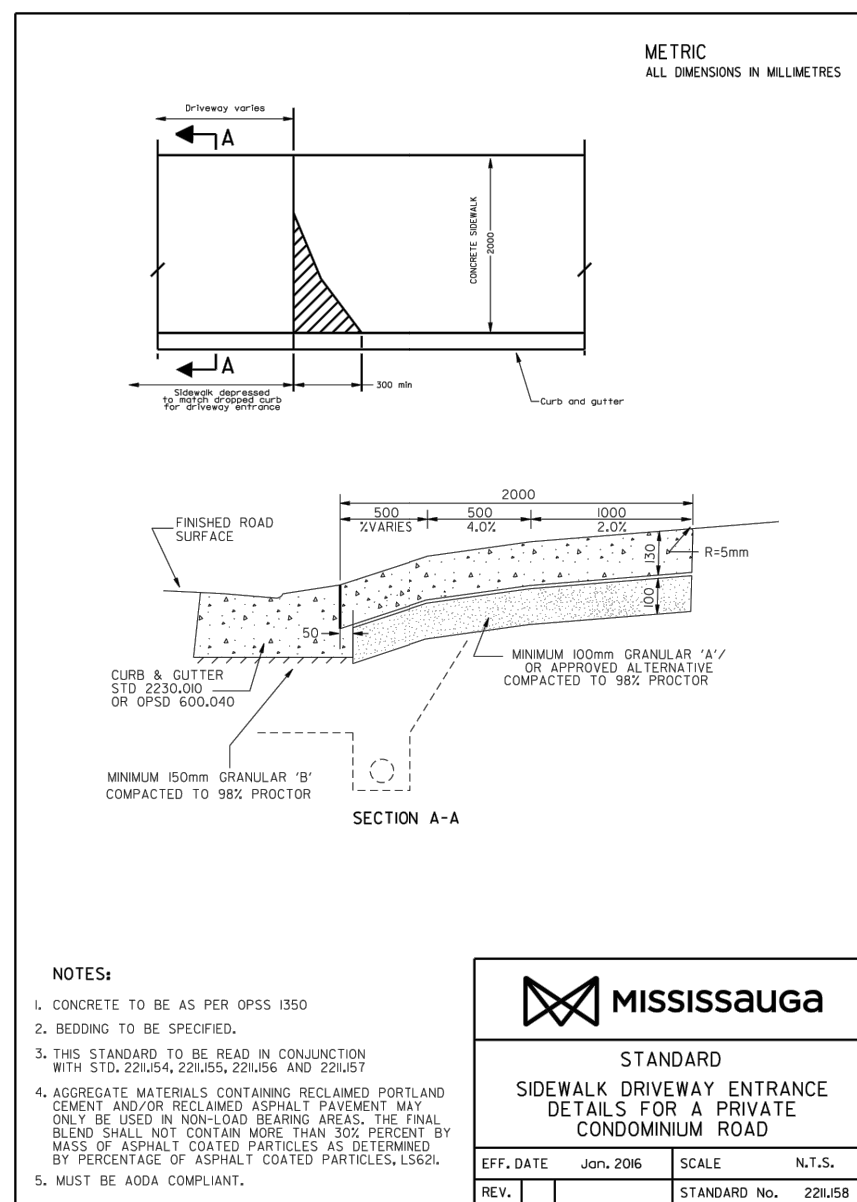

7 CITY OF MISSISSAUGA - SIDEWALK DRIVEWAY ENTRANCE  
SCALE=N.T.S.

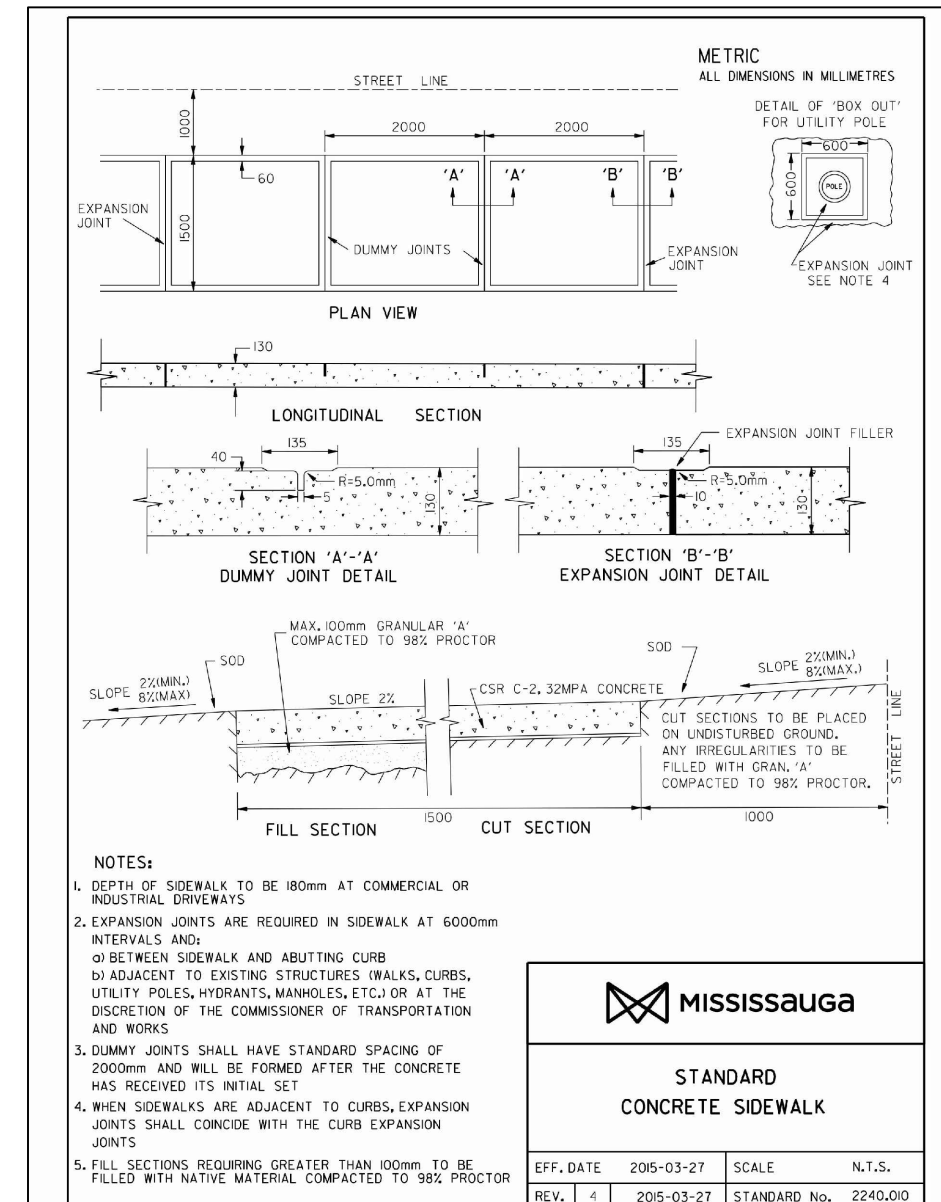

8 CITY OF MISSISSAUGA - STANDARD CONCRETE SIDEWALK  
SCALE=N.T.S.

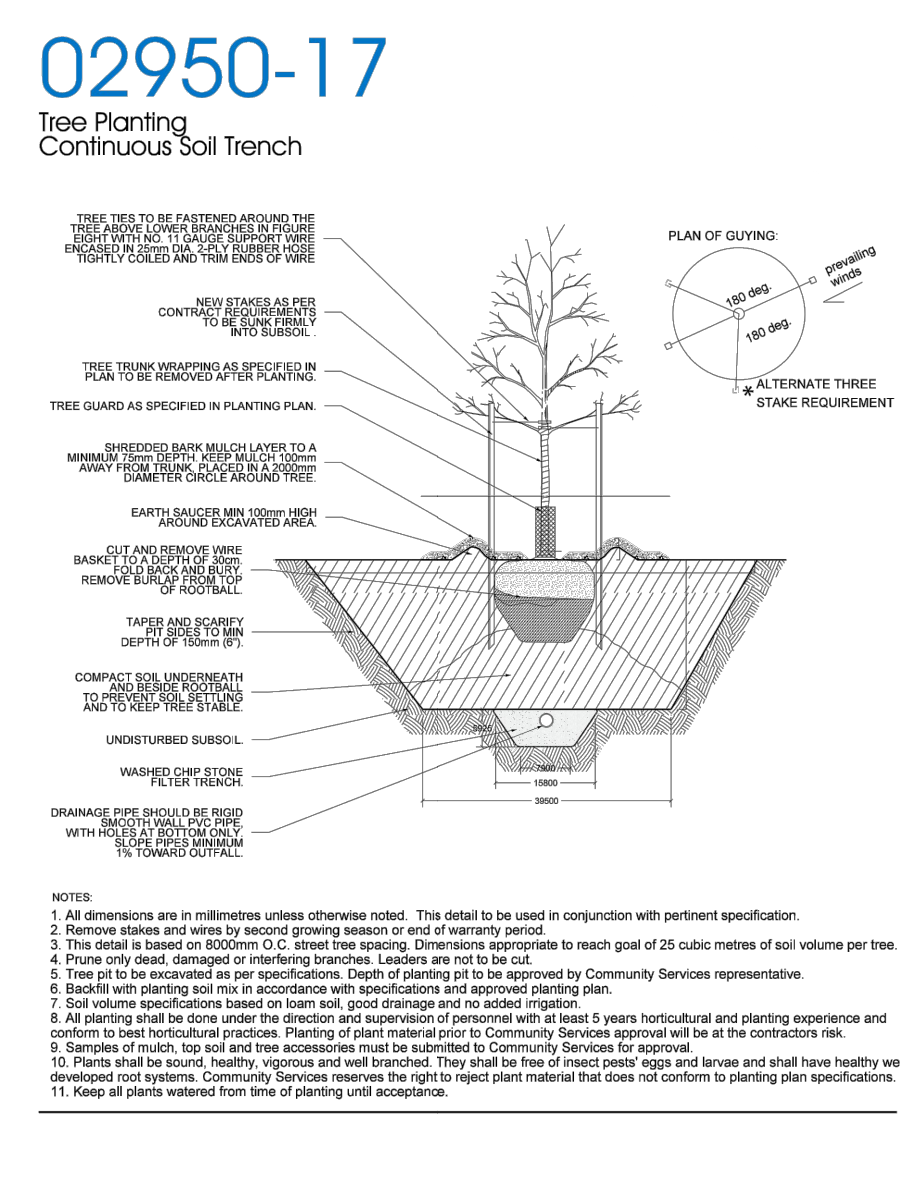

9 CITY OF MISSISSAUGA - CONTINUOUS SOIL TRENCH  
SCALE=N.T.S.

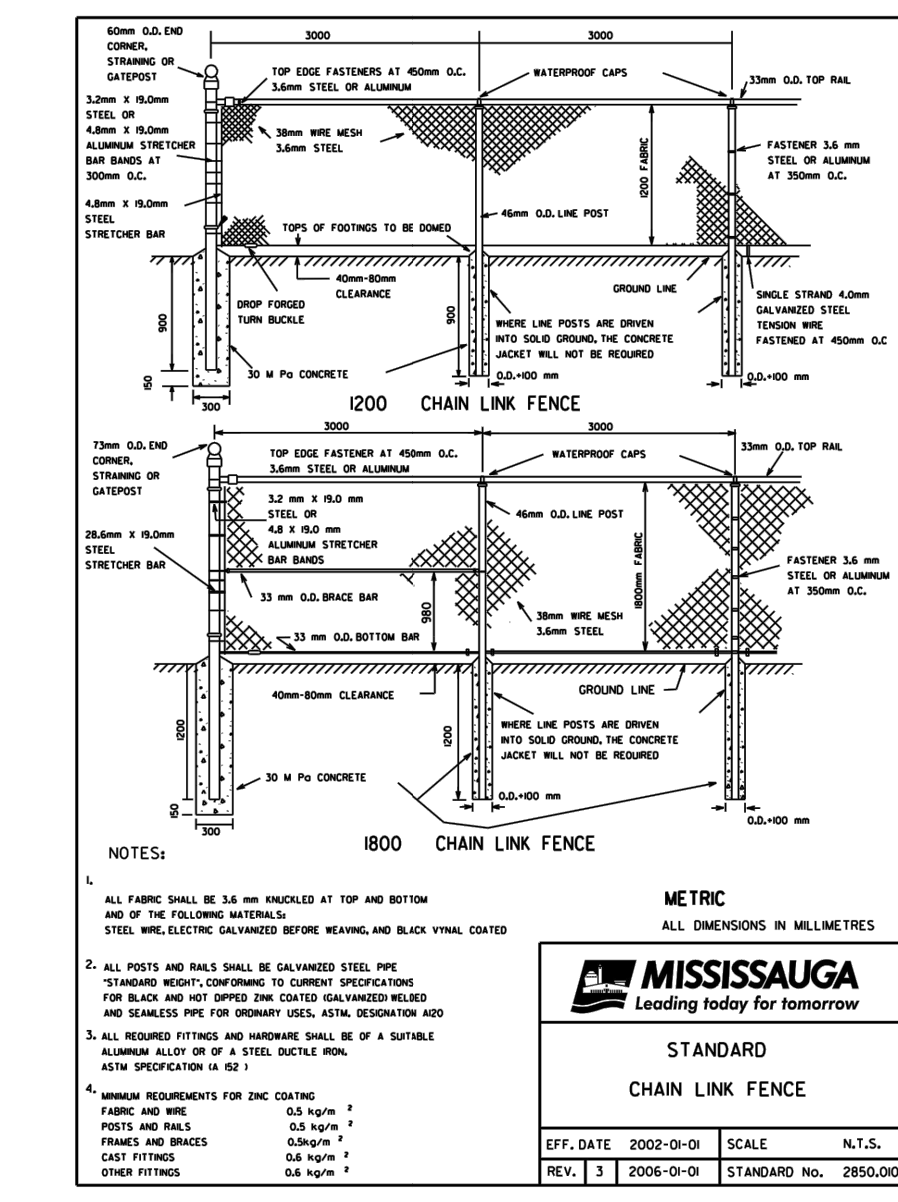

10 CITY OF MISSISSAUGA - CHAIN LINK FENCE  
SCALE=N.T.S.

no.	revision	date	by
2	ISSUED FOR ZBA & SPA	2022-12-15	CZ
1	ISSUED FOR ZBA	2022-02-22	CZ

CONTRACTOR MUST VERIFY ALL DIMENSIONS ON THE JOB AND REPORT ANY DISCREPANCY TO THE LANDSCAPE ARCHITECT BEFORE PROCEEDING WITH THE WORK. ALL DRAWINGS AND SPECIFICATIONS ARE INSTRUMENTS OF SERVICE AND THE PROPERTY OF THE LANDSCAPE ARCHITECT WHICH MUST BE RETURNED AT THE COMPLETION OF THE WORK. ALL DRAWINGS TO BE USED FOR CONSTRUCTION ONLY WHEN SIGNED BY THE LANDSCAPE ARCHITECT.

signed \_\_\_\_\_ date \_\_\_\_\_

**STUDIO tla**  
20 Champian Blvd. Suite 102 - Toronto ON - M3H 2Z1 info@studiotla.ca www.studiotla.ca

**almeqa**

CLIENT  
60 DUNDAS STREET EAST  
MISSISSAUGA, ONTARIO

PROJECT  
LANDSCAPE DETAILS

DRAWING  
DRAWN: CZ / JB  
CHECKED: RR  
SCALE: AS SHOWN  
DATE: 2022-01-26  
PROJECT NO: 22-105

ASSOCIATION OF LANDSCAPE ARCHITECTS  
DAVID S. JONES  
MEMBER  
SOCIETY

LS.201