

Transportation Impact Study Update

PROPOSED RESIDENTIAL DEVELOPMENT

8, 10 & 12 Queen Street S and
2 William Street & 16 James Street
MISSISSAUGA, ONTARIO

January 2023
Project No: NT-20-212

520 Industrial Parkway South, Suite 201
Aurora ON L4G 6W8

Phone: 905-503-2563
www.nexttrans.ca

nexttrans
CONSULTING ENGINEERS

NextEng Consulting Group Inc.

January 18, 2023

Attention: Giancarlo Pennino

City Park Homes
950 Nashville Road
Kleiburg, ON L0J 1C0

**Re: Transportation Impact Study
Proposed Residential Development
8, 10 & 12 Queen Street S and 2 William Street & 16 James Street
City of Mississauga
Our Project No. NT-20-212**

Nexttrans Consulting Engineers (a Division of NextEng Consulting Group Inc.) is pleased to present the enclosed Transportation Impact Study for the above noted site in support of a Site Plan Application for a proposed residential development.

The subject property is located 8, 10 & 12 Queen Street S and 2 William Street & 16 James Street, at the south-west quadrant of the Britannia Road W/Queen Street S intersection, in the City of Mississauga. The proposed development consists of two buildings of different heights (ranging from 2-8 storeys) with a total of 232 residential dwelling units, as well as a ground related non-residential use of 554.3 m² gross floor area. A full moves site access will be provided onto James Street accommodate the proposed development. The proposed development will provide a total of 239 vehicle parking spaces, including 193 resident, 46 visitor and barrier free spaces, as well as minimum of 159 bicycle parking spaces (inclusive of Class A and Class B spaces).

The Study concludes that the proposed development can adequately be accommodated by the existing transportation network, excellent existing Mississauga Transit Services and the Transportation Demand Management measures and incentives recommended in this report.

We trust the enclosed sufficiently addresses your needs. Should you have any questions, please do not hesitate to contact the undersigned.

Yours truly,

Nexttrans Consulting Engineers

A Division of NextEng Consulting Group Inc.
Prepared by:



Peter Ilias, P.Eng.
Senior Engineer



Sam Nguyen, Dipl.
Transportation Analyst

Reviewed and Approved by:



Richard Pernicky, MITE
Principal

Report Submission Record

Identification	Date	Description of issued and/or revision
Final Report	January 18, 2023	For Final Submission

EXECUTIVE SUMMARY

Nextrans Consulting Engineers (A Division of NextEng Consulting Group Inc.) was retained by City Park Homes Inc. (the 'Client') to undertake a Transportation Impact Study Update in support of a Site Plan application for a proposed mixed-use development. The subject property is located 8, 10 & 12 Queen Street S and 2 William Street & 16 James Street, at the south-west quadrant of the Britannia Road W/Queen Street S intersection, in the City of Mississauga.

Nextrans has prepared a comprehensive Transportation Impact Study dated August, 2021 in support of the previous development proposal. That Study was followed the approved terms of reference by the City of Mississauga. The Study terms of reference are included in **Appendix A** of this Study. The purposes of this Study are to assess the latest development proposal and to address the City's comments provided on the previous submission.

The City and Region Comments on Previous Submission

As the current development proposal is different from the previous proposed development plan, some of the comments provided by the City and the Region on the previous submission may not be applicable. However, the following are some of the comments by the City and the Region have been addressed in this Study Update:

1. New traffic turning movement counts as the previous counts were too old

Response: Nextrans has updated the intersection counts for the study area intersection

2. Figure 4 shown in the report does not reflect Mississauga Cycling Master Plan, Figure 15 Proposed cycling network. Please verify existing current condition.

Response: Nextrans has confirmed with a site visit for the existing facilities shown on the map of this Study.

3. 51 & 57 Tannery Street and 208 Emby Drive (T 20-4 & OZ 16-11) must be considered as background developments.

Response: This background development, among other background developments in the area, have been reflected in the analysis

4. Please clarify how trip distribution and assignment is determined using existing turning movement counts at the McLaughlin Road/Navigator Drive intersection.

Response: This is a typo, the site trip distribution and assignment are based on the 2016 TTS data, along with the logical routing of the existing road network and restrictions, where appropriate.

5. Please demonstrate clearly the trip distribution and assignment for all proposed access and provide rationales reflective of the multiple accesses proposed for this development.

Response: The new proposed development plan only provides one access onto James Street. The site traffic assignment and distribution are based on the 2016 TTS data.

6. Furthermore, as per the ToR, a complete site access review is required for ALL proposed accesses. Review corner clearances, sightline distances, proximity to utilities and other driveways/roads in accordance to TAC standards. Revise the report accordingly.

Response: The new proposed development plan only provides one access onto James Street. The proposed access will be designed in accordance with TAC and City's requirement at the site plan stage.

7. Queue Length – 2028 Future Total NBL for Queen Street S. at Britannia Road W. exceed existing exclusive left turn queue length to be utilized as northbound left turn movement entering accesses along Queen Street S. Please provide justification on how these movements will operate safely with the introduction of accesses along Queen Street S. during peak hours.

[Response:](#) Based on the analyses provided in this Study Update, these operational issues have been addressed and the proposed development no longer provide any site accesses onto Queen Street South.

8. The Future Total condition should include all proposed accesses. Please revise figures accordingly.

[Response:](#) Noted and included in this Study Update.

9. The Traffic Impact Study is to include an additional section for Collision Analysis. The collision analysis should include intersections at Britannia Road at Queens Street North/South, Queens Street South at James Street, and the mid-block section of Queen Street South between these intersections. Please contact William Wright from T&W Road Safety (William.Wright@mississauga.ca, Ext. 3221) for existing traffic related complains and collision history.

[Response:](#) As indicated, the proposed development no longer provide any site accesses onto Queen Street South. The proposed development access onto James Street is located at similar location as the existing access today. The analyses provided in this Study indicate that there are no safety concerns related to access and traffic operations.

10. The TIS shall include a section in the report to address Community Impacts.

[Response:](#) Noted and included in this Study Update.

11. This section shall include summary statements outlining the resulting traffic increases to the critical streets, movements and intersections. Comments or concerns from the community through future public meetings and engagements that are related to traffic shall also be addressed in this section.

[Response:](#) Noted and included in this Study Update, where appropriate.

Proposed Development

Currently, the subject site is occupied by several residential properties, some businesses and a storage yard. The current development proposal consists of two buildings of different heights (ranging from 2-8 storeys) with a total of 232 residential dwelling units, as well as a ground related non-residential use of 554.3 m² gross floor area.

Proposed Development Access

Under the existing conditions, the existing residential properties have direct accesses onto Queen Street S. The remainder of the site has two full moves accesses onto James Street. Based on the City's comments and concerns, the current development will only provide one full moves access onto James Street to accommodate the proposed development. All other existing accesses will be closed.

The analysis indicates that the proposed access onto James Street is expected to operate at acceptable levels of service with negligible queues or delays. Based on the intersection capacity analysis and site context, the proposed lane configurations include: one inbound and one outbound (3.5 m width for each lane) and a shared westbound through/right and an eastbound shared through/left on James Street. No exclusive turning lanes are required at the proposed site access.

Capacity Analysis

The proposed development is expected to generate:

- 90 total two-way auto trips (21 inbound and 69 outbound) and 91 total two-way auto trips (56 inbound and 35 outbound) during the AM and PM peak hours, respectively; and
- 35 total two-way transit trips (8 inbound and 27 outbound) and 22 total two-way transit trips (13 inbound and 9 outbound) during the AM and PM peak hours, respectively

Auto Mode Assessment

The intersection capacity analysis indicates that under the existing, future background and future total traffic conditions, all intersections are expected to operate at acceptable levels of service. There are several critical movements at the Britannia Road W/Queen Street S intersection such as the and eastbound left turn during the morning peak hour and northbound left turn during the afternoon peak hour. These are results of existing and future background traffic on Britannia Road W and Queen Street S.

The potential mitigation measures for these movements would be optimizing the existing signal timing plan to allocate additional green time for these two movements and balance other movements. Although this measure may not address all of the critical movements, however, this measure is less disruptive and more cost effective than intersection widening. It should be noted that intersection widening will impact pedestrian distance crossing and will increase usage of private vehicles. The other measures may also include, but not limited to vehicle parking reduction and appropriate TDM measures for all background developments in the area, and future improvements of the active transportation network in the area.

The analysis indicates that the proposed development has negligible impacts to the roadway intersections.

Active Transportation Mode Assessment

Walking

Under the existing conditions, sidewalks are available on both sides of Britannia Road W along the frontage of the proposed development. Sidewalks are also available on both sides of Queen Street S south of Britannia Road W. Sidewalk is only available on the north side of James Street, about 50 m west of Queen Street S. Sidewalks are currently not available on William Street south of James Street.

As part of the proposed development, sidewalks be provided at least on one side all of the internal roads to accommodate pedestrian circulation. These sidewalks will be connected to Queen Street S and James Street, where appropriate. **Figure 12** illustrates the proposed internal sidewalk locations.

Cycling

Under the existing conditions, based on site visit and a review of the City's Cycling Map, there are no dedicated bicycle lanes in the immediate area, however, dedicated cycling lanes are available on Tenth Line and Bristol Road W and a short section of Queen Street S south of Erin Centre Blvd. There are several multi-use trails in the immediate area such as on the south side of Britannia Road W, Thomas Street west of Erin Mills, Winston Churchill Boulevard and a short section of Creditview Road.

As indicated under the existing condition assessment, the existing cycling network can be improved in the future as part of the City of Mississauga 2018 Cycling Master Plan to install more bicycle facilities on Queen Street S and Queen Street N in the area. This will encourage existing and future residents to use these facilities instead of driving single-occupant-vehicles.

As part of the proposed development, a total of 159 bicycle parking spaces will be provided on site. In addition, Nexttrans recommends that the proposed development provides one bicycle repair station on site, at a convenient location that can be easily accessed by residents.

Transit Mode Assessment

The analysis indicates that the proposed development is expected to generate 35 total two-way transit trips (8 inbound and 27 outbound) and 22 total two-way transit trips (13 inbound and 9 outbound) during the AM and PM peak hours, respectively

As indicated in Section 2.4 of the Study, the proposed development is located adjacent to Routes 44 Mississauga, 39 Britannia, 10 Bristol-Britannia, 87 Meadowvale-Skymark and Route 43 Matheson-Argentia. In addition, the site is located about 5.5 km from Hurontario Street, approximately 25-minute bike ride or 150-minute bus ride. Residents can connect with the future Hurontario LRT via Route 39 Britannia and/or Route 10 Bristol-Britannia. The proposed development is also located about 1.4 km to the existing Streetsville GO Train Station (or 6-minute bike ride).

The analysis indicates that the proposed development transit ridership can be easily accommodate by the existing excellent transit services and no improvements are required at this time to accommodate the proposed development.

Vehicle Parking Review

Based on the applicable Zoning By-law, the proposed development would be required to provide a total of 255 vehicle parking spaces, inclusive of residential, visitor and retail uses.

Nexttrans has provided a comprehensive justification in this Study and recommended appropriate rates for the proposed development. Based on the recommended vehicle parking rates, the proposed development will provide a total of 239 vehicle parking spaces for both resident, visitor and non-residential components. This includes 193 residential vehicle parking spaces and 46 visitor/non-residential shared vehicle parking spaces.

Bicycle Parking Review

Based on the City's Zoning By-law, the proposed development is required and will provide a minimum of 159 bicycle parking spaces, including 18 Class B (short-term spaces for visitors and non-resident) and 141 Class A (long-term spaces for resident).

Nexttrans also recommends that the proposed development provides one bicycle repair station on-site, at convenient location where residents can easily have access to.

The analysis indicates that the proposed bicycle parking supply by the proposed development will support the vehicle parking reduction as this will encourage residents to take active mode of transportation to work, school and discretionary trips instead of driving private vehicles.

Transportation Demand Management Measures and Incentives

The TDM measures and incentives related to the proposed development have been assessed and recommended in Section 9 of this report to support active transportation and transit, to meet the objectives and requirements of the City of Mississauga sustainable transportation objectives.

Loading Requirement

The proposed development provides one loading space on-site based on the Zoning By-law requirement. AutoTURN software was used (Garbage truck TAC-HSU and passenger vehicle) to generate vehicular turning templates to confirm and demonstrate the accessibility for the proposed on-site loading space.

Study Conclusions and Recommendations

Based on the Study assessment, the following recommendations are provided:

- The proposed development implements the TDM measures recommended in this Study;
- The proposed development provides the sidewalk network as illustrated in **Figure 12**;
- Provide one bicycle repair station on-site, at a convenient location;
- The proposed development access configuration includes: one inbound and one outbound (3.5 m width for each lane) and a shared westbound through/right and an eastbound shared through/left on James Street. No exclusive turning lanes are required at the proposed site access;
- The Region/City considers optimize the existing signal timing plan for the Queen Street South/Britannia Road W intersection to improve some critical movements, where appropriate; and
- No additional physical improvements for the area road network and intersections to accommodate the proposed improvements

TABLE OF CONTENTS

1.0	INTRODUCTION	1
2.0	EXISTING TRAFFIC CONDITIONS	2
2.1.	Existing Road Network.....	2
2.2.	Existing Active Transportation Network.....	3
2.3.	Existing Active Transportation Assessment.....	4
2.4.	Existing Mississauga Transit Service	4
2.3.	Existing Transit Assessment.....	5
2.4.	Existing Traffic Volumes	5
2.5.	Existing Traffic Assessment.....	6
3.0	TRANSPORTATION PLANNING CONTEXT IN THE AREA.....	7
3.1.	Land Use Context.....	7
3.2.	Transportation Planning Context	7
4.0	FUTURE BACKGROUND CONDITIONS	8
4.1.	Analysis Horizon.....	8
4.2.	Future Background Corridor Growth	8
4.3.	Background Development Applications	8
4.4.	Future Background Traffic Assessment.....	9
5.0	SITE TRAFFIC	12
5.1.	Proposed Development.....	12
5.2.	Modes of Travel Assessment in the Area.....	12
5.3.	Site Trip Generation.....	13
5.4.	Site Trip Distribution and Assignment.....	13
6.0	FUTURE TOTAL TRAFFIC CONDITIONS	14
6.1.	Future Total Traffic Assessment for Auto Mode	14
6.2.	Potential Mitigation Measures	17
6.3.	Active Transportation Assessment.....	17
6.4.	Transit Mode Assessment.....	17
7.0	SITE PLAN REVIEW AND COMMUNITY CONCERNS.....	18
7.1.1.	Proposed Development Access	18
7.1.2.	Traffic Calming Review.....	19
7.1.3.	Access Sightlines	19
7.1.4.	Operational Concerns.....	19
7.1.5.	Loading Requirement	19
7.1.6.	Solid Waste Management	19
7.2.	Pavement Marking and Signage Plan	20

8.0	PARKING ASSESSMENT	20
8.1.	Zoning By-law Vehicle Parking Requirement	20
8.2.	Benefits of Vehicle Parking Reduction	21
8.2.1.	Appropriate Parking Management is the best TDM Measure	21
8.2.2.	Support Alternative Modes of Transportation	21
8.3.	Recommended Vehicle Parking Requirement for the Proposed Development.....	22
9.0	VEHICLE PARKING JUSTIFICATION.....	22
9.1.	Subject Site Strategic Location	22
9.2.	Subject Site Walk Score	22
9.3.	Existing Mode Share.....	23
9.4.	City of Mississauga Parking Master Plan and Implementation Strategy (May 2019).....	23
9.5.	Housing Affordability and Crisis	24
9.6.	Covid-19 Pandemic and Working from Home	24
9.7.	A Reduction to the Minimum Vehicle Parking Requirements is Consistent with Provincial and Regional Direction	24
9.8.	High Residential Vehicle Parking Rates Result in More Car Ownership and More Driving While Reducing Transit Usage.....	25
9.9.	A Reduction to the Minimum Vehicle Parking Requirements Increases the Supply of Affordable Housing	27
	City of Toronto	27
	City of Edmonton	27
	Other Cities in the United States.....	27
	City of Vaughan	28
	City of Ottawa	28
	North Oakville (Town of Oakville)	28
	City of Brampton	28
9.10.	A Reduction to the Minimum Vehicle Parking Requirements Will Help Supporting Local Businesses.....	29
9.11.	A Reduction to the Minimum Vehicle Parking Requirements has a Number of General Benefits	29
9.12.	Region of Peel Sustainable Transportation Strategy	29
9.13.	City of Mississauga Official Plan.....	30
9.14.	City of Mississauga Cycling Master Plan Update	30
9.15.	Conclusion on Why Vehicle Parking Rate Reduction is Justified.....	30
10.0	BICYCLE PARKING ASSESSMENT	31
11.0	TRANSPORTATION DEMAND MANAGEMENT.....	31
12.0	CONCLUSIONS / FINDINGS	32
12.1.	Study Conclusions.....	32
12.2.	Study Recommendations	33

LIST OF FIGURES

- Figure 1 – Proposed Development Location
- Figure 2 – Proposed Site Plan
- Figure 3 – Existing Lane Configuration and Traffic Control
- Figure 4 – Existing Cycling Network in the Study Area
- Figure 5 – Existing Transit Network in the Study Area
- Figure 6 – Existing Traffic Volumes (Balanced)
- Figure 7 – 2028 Corridor Background Through Traffic Growth (Balanced)
- Figure 8 – Background Development Traffic Volumes
- Figure 9 – 2028 Future Background Traffic Volumes
- Figure 10 – Site Traffic Volumes
- Figure 11 – 2028 Future Total Traffic Volumes
- Figure 12 – Proposed Internal Sidewalk Connections
- Figure 13 – Preliminary Proposed Pavement Marking and Signage Plan
- Figure 14 – Survey Responses for Car Ownership by Residential Parking Ratio
- Figure 15 – AutoTURN Analysis (Garbage Truck)
- Figure 16 – AutoTURN Analysis (Fire Truck)

LIST OF TABLES

- Table 1 – Existing Levels of Service
- Table 2 – 2028 Future Background Levels of Service
- Table 3 – Modal Split based on 2016 TTS Data for Traffic Zones
- Table 4 – Site Trip Generation
- Table 5 – Trip Distribution for Residential Component
- Table 6 – Site Trip Distribution
- Table 7 – 2028 Future Total Levels of Service
- Table 8 – City of Mississauga Zoning By-law Vehicle Parking Requirements
- Table 9 – Recommended Vehicle Parking Rates for the Proposed Development
- Table 10 – Walk Score for 2 Queen Street South
- Table 11 – Modal Split based on 2016 TTS Data for Traffic Zones
- Table 12 – Bicycle Parking Space Requirements

APPENDICES

- Appendix A – Terms of Reference and Existing Traffic Data
- Appendix B – Existing Traffic Level of Service Calculations
- Appendix C – Background Development Trip Generation and Traffic Volumes
- Appendix D – Future Background Traffic Level of Service Calculations
- Appendix E – 2016 Transportation Tomorrow Survey (TTS) Data Analysis
- Appendix F – Future Total Traffic Level of Service Calculations
- Appendix G – City of Mississauga Zoning By-Law

1.0 INTRODUCTION

Nextrans Consulting Engineers (A Division of NextEng Consulting Group Inc.) was retained by City Park Homes Inc. (the 'Client') to undertake a Transportation Impact Study Update in support of a Site Plan application for a proposed mixed-use development. The subject property is located 8, 10 & 12 Queen Street S and 2 William Street & 16 James Street, at the south-west quadrant of the Britannia Road W/Queen Street S intersection, in the City of Mississauga. The location of the proposed development is illustrated in **Figure 1**.

Nextrans has prepared a comprehensive Transportation Impact Study dated August, 2021 in support of the previous development proposal. That Study was followed the approved terms of reference by the City of Mississauga. The Study terms of reference are included in **Appendix A** of this Study. The purposes of this Study are to assess the latest development proposal and to address the City's comments on the previous submission.

Figure 1 – Proposed Development Location

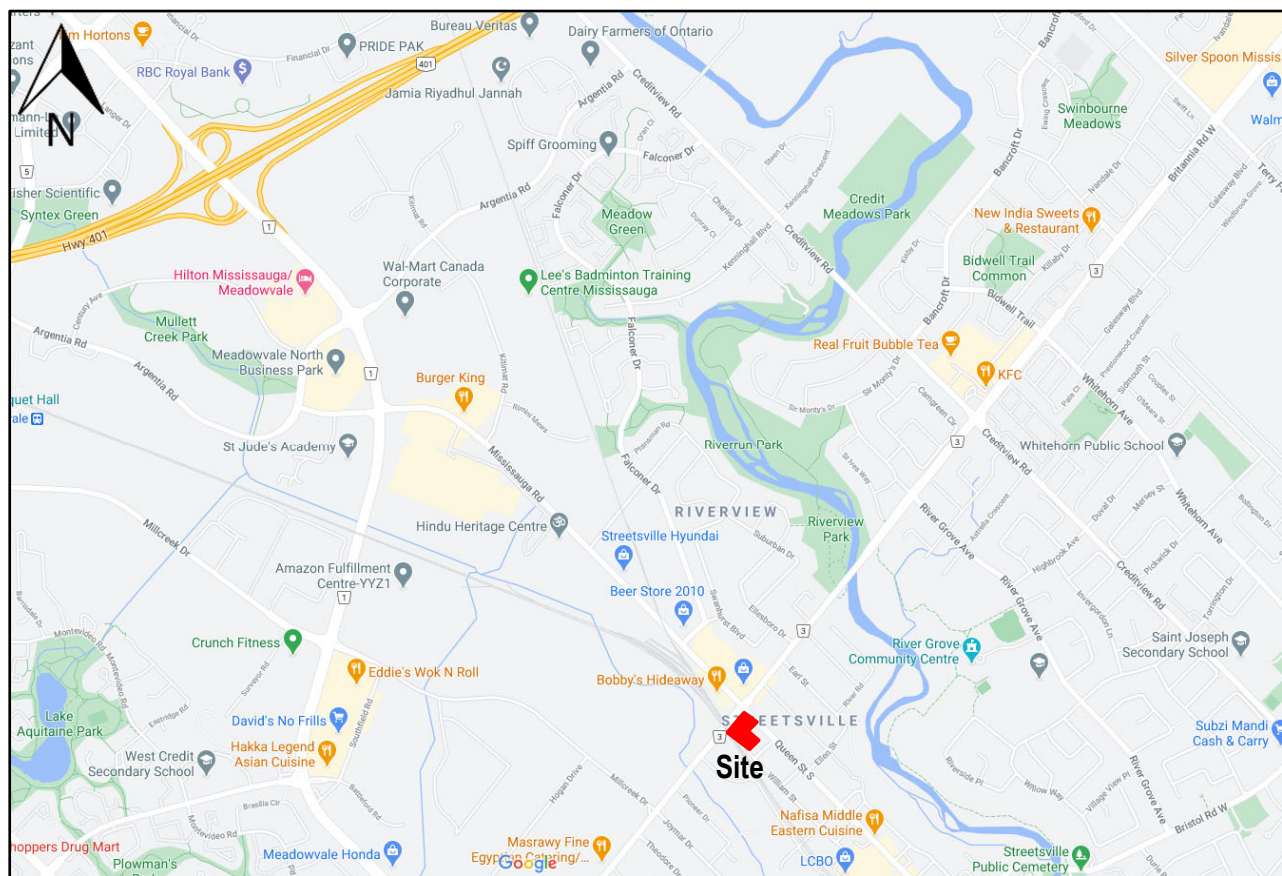

Source: Google Map

Currently, the subject site is occupied by several residential properties, some businesses and a storage yard. The current development proposal consists of two buildings of different heights (ranging from 2-8 storeys) with a total of 232 residential dwelling units, as well as a ground related non-residential use of 554.3 m² gross floor area. The proposed development will provide a total of 239 vehicle parking spaces, including 193 resident, 46 visitor and barrier free spaces, as well as a minimum of 159 bicycle parking spaces, including 18 Class B spaces (short-term spaces for visitors and non-resident) and 141 Class A spaces (long-term spaces for resident).

Under the existing conditions, the existing residential properties have direct accesses onto Queen Street S. The remainder of the site has two full moves accesses onto James Street. Based on the City's comments and concerns, the current development will only provide one full moves access onto James Street to accommodate the proposed development. All other existing accesses will be closed. **Figure 2** illustrates the proposed development site plan.

Figure 3 – Existing Lane Configuration and Traffic Control

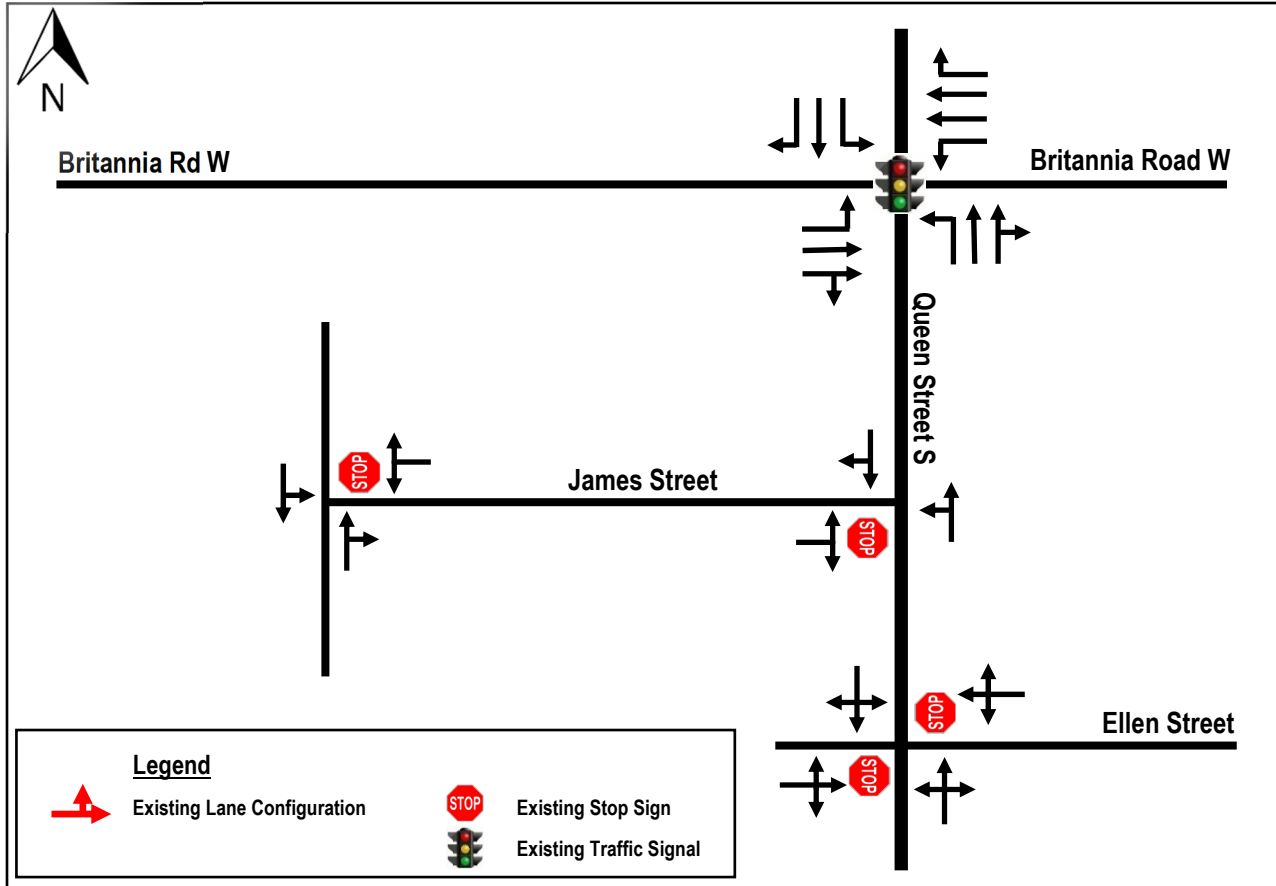

2.2. Existing Active Transportation Network

Figure 4 illustrates the existing active transportation network in the study area based on the City's 2018 Cycling Map and site visit.

Figure 4 – Existing Cycling Network in the Study Area

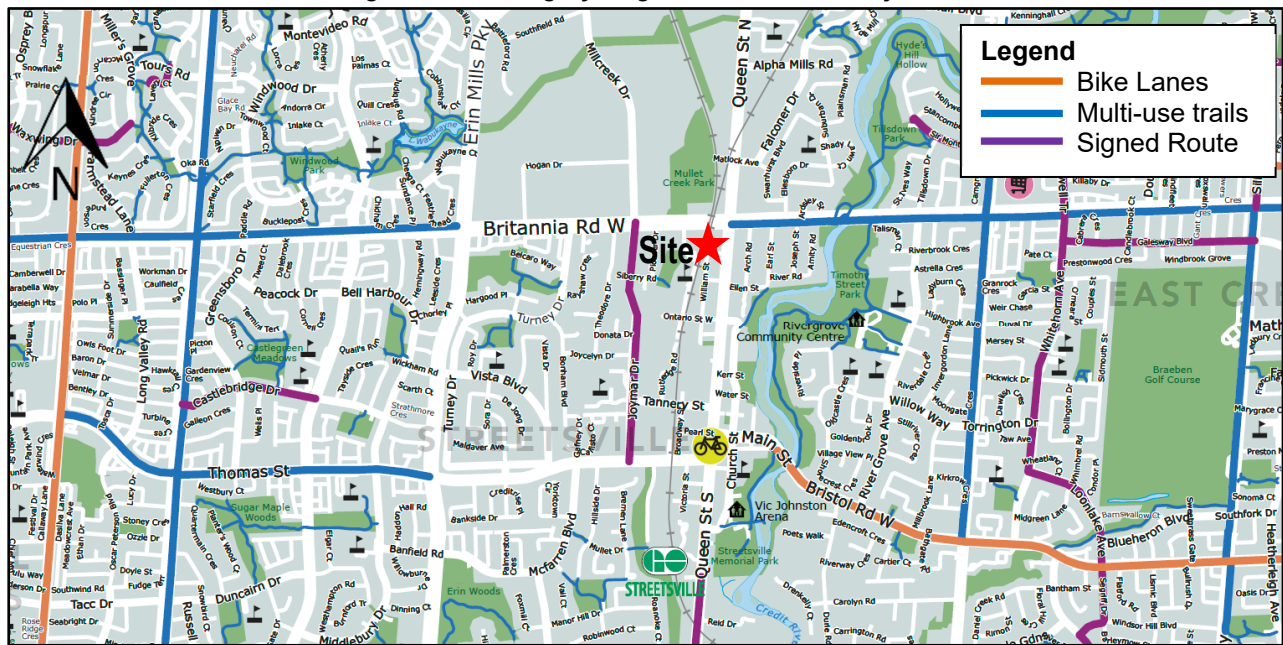

2.3. Existing Active Transportation Assessment

Walking

Under the existing conditions, sidewalks are available on both sides of Britannia Road W along the frontage of the proposed development. Sidewalks are also available on both sides of Queen Street S south of Britannia Road W. Sidewalk is only available on the north side of James Street, about 50 m west of Queen Street S. Sidewalks are currently not available on William Street south of James Street. Improvements are not required at this time.

Cycling

Under the existing conditions, there are no dedicated bicycle lanes in the immediate area, however, dedicated cycling lanes are available on Tenth Line and Bristol Road W and a short section of Queen Street S south of Erin Centre Blvd. There several multi-use trails in the immediate area such as on the south side of Britannia Road W, Thomas Street west of Erin Mills, Winston Churchill Boulevard and a short section of Creditview Road.

The analysis indicates that the existing cycling network can be improved in the future as part of the City of Mississauga 2018 Cycling Master Plan to install more bicycle facilities on Queen Street S and Queen Street N in the area. This will encourage existing and future residents to use these facilities instead of driving single-occupant-vehicles.

2.4. Existing Mississauga Transit Service

The proposed development is located adjacent to Routes 44 Mississauga, 39 Britannia, 10 Bristol-Britannia, 87 Meadowvale-Skymark and Route 43 Matheson-Argentia. In addition, the site is located about 5.5 km from Hurontario Street, approximately 25-minute bike ride. Residents can connect with the future Hurontario LRT via Route 39 Britannia and/or Route 10 Bristol-Britannia. The proposed development is also located about 1.4 km to the existing Streetsville GO Train Station (or 6-minute bike ride). The existing transit network in the area is illustrated in **Figure 5**.

Figure 5 – Existing Transit Network in the Study Area

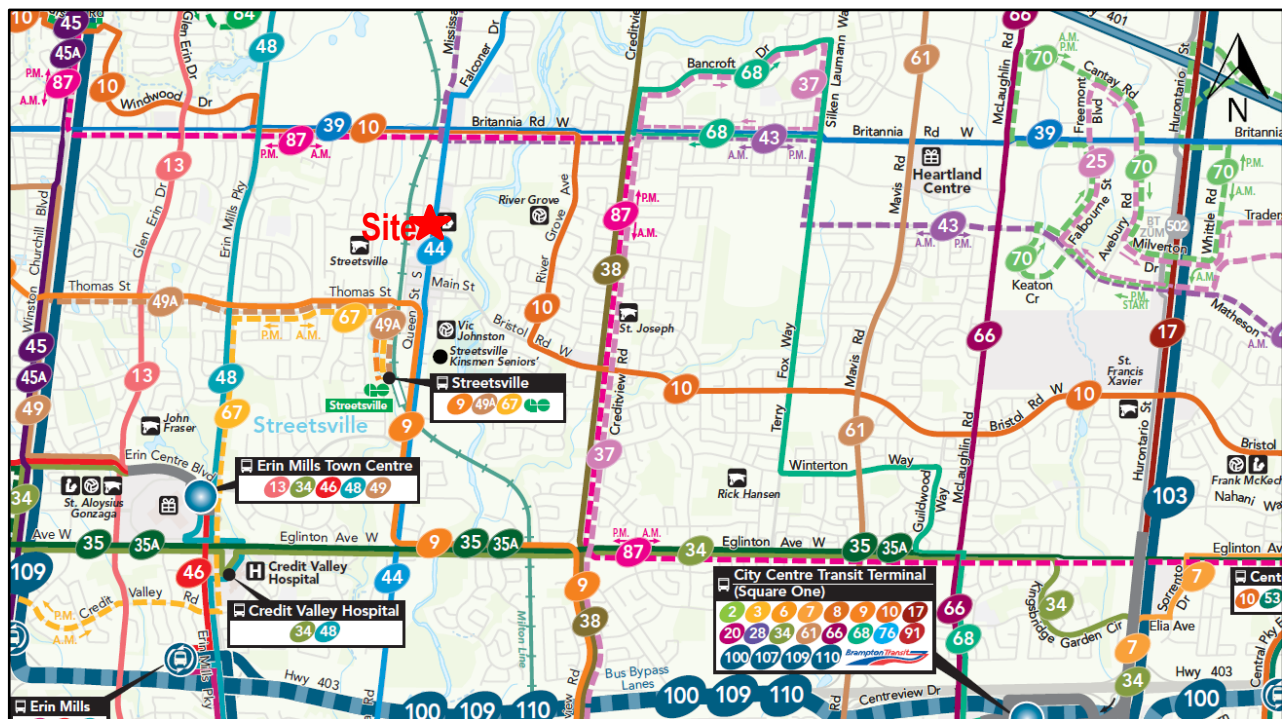

Source: Mississauga Transit Website (<https://web.mississauga.ca/miway-transit/>)

Mississauga Transit service descriptions are outlined below:

- **Route 44 Mississauga Road** – This Route is running generally in the north-south direction along Mississauga Road and Queen Street S between University of Toronto Mississauga Campus and Meadowvale Town Centre Drop-off. The service frequency is approximately 21-22 minutes during both the weekday morning and afternoon peak periods.
- **Route 10 Bristol-Britannia** – This Route is generally operating in the east-west direction from Square One (City Centre Transit Terminal Platform J) to Meadowvale Town Centre Drop-off. The service frequency is approximately 22-23 minutes during both the weekday morning and afternoon peak periods.
- **Route 39 Britannia** – This route is generally operating in the east-west direction from Renforth Station East Platform 7 to Meadowvale Town Centre Drop-off. The service frequency is approximately 23 minutes during both the weekday morning and afternoon peak periods.
- **Route 87 Meadowvale-Skymark** – This route is generally operating in the east-west direction from Meadowvale Town Centre to Commerce Boulevard at Renforth Station. The service frequency is approximately 45 minutes during both the weekday morning and afternoon peak periods (directional).
- **Route 43 Matheson-Argentia** – This route is generally operating in the east-west direction from Meadowvale Town Centre to Skymark Avenue at Commerce Blvd. The service frequency is approximately 45 minutes during both the weekday morning and afternoon peak periods (directional).

2.3. Existing Transit Assessment

Based on Nextrans' review of the existing Mississauga Transit/MiWay operating schedule, as well as the context of the study area, indicates that the area is currently has excellent transit service. Even during the pandemic, the existing Routes 44 Mississauga Road, Route 10 Bristol-Britannia and Route 39 Britannia have excellent service frequency (21-23 minutes) that connect residents to City Centre Transit Terminal and Meadowvale Town Centre. The analysis indicates that the existing transit service is excellent in the area there is no noticeable constrain in service at this time.

2.4. Existing Traffic Volumes

As requested by the City staff, updated traffic turning movement counts have been undertaken for the following intersections:

- Queen Street S and Britannia Road W (signalized) – Count date Tuesday June 7, 2022
- Queen Street S and Ellen Street (unsignalized) – Count date Tuesday June 7, 2022
- Queen Street S and James Street (unsignalized) – Count date Tuesday June 7, 2022
- James Street at William Street (unsignalized) – Count date Tuesday June 7, 2022

The turning movement counts were conducted during the morning (7:00 a.m. to 9:00 a.m.) and afternoon (4:00 p.m. to 6:00 p.m.) peak periods for all area intersections.

Turning movement counts are included in **Appendix A**. The existing volumes are illustrated in **Figure 6**.

Figure 6 – Existing Traffic Volumes (Balanced)

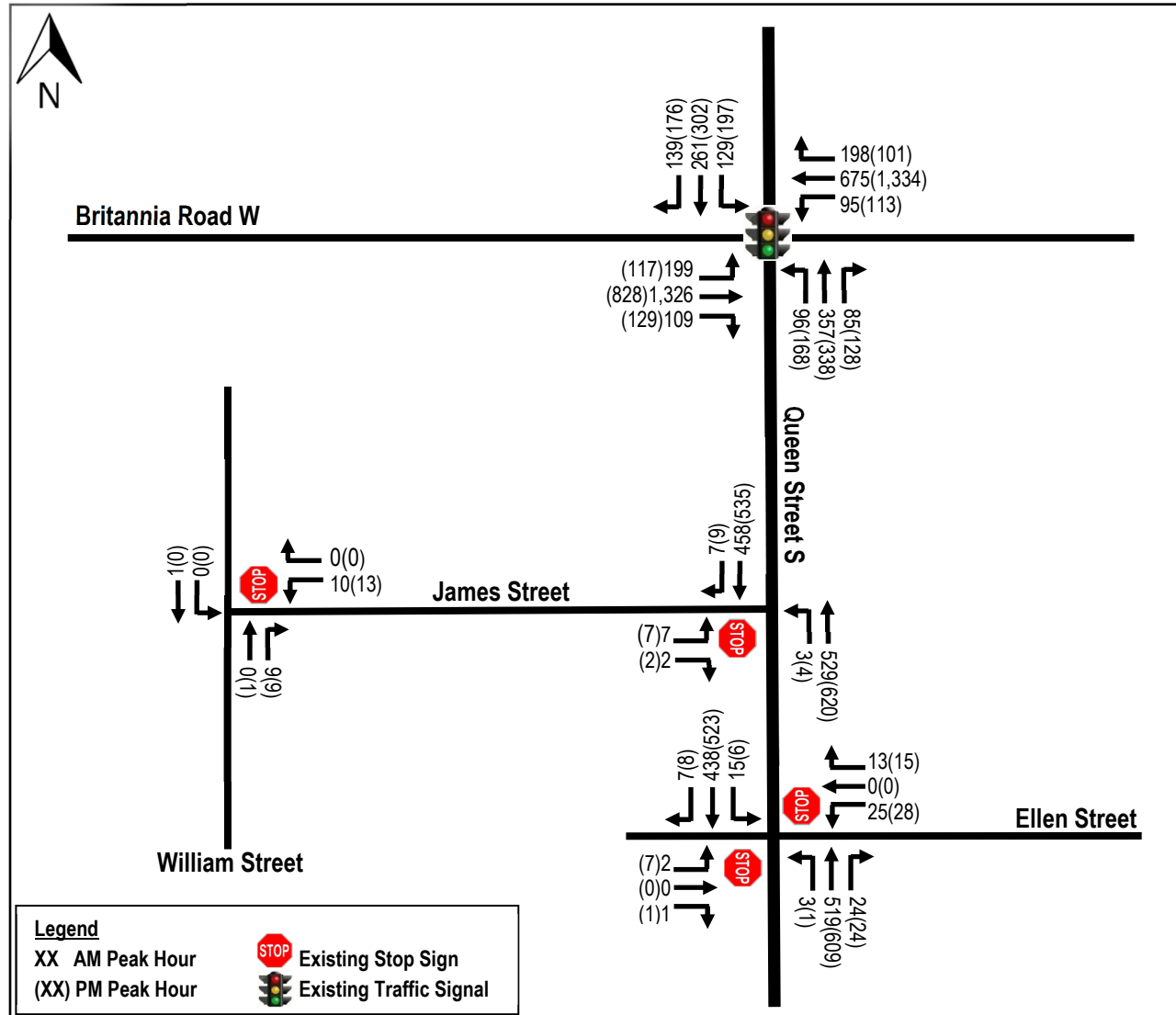

2.5. Existing Traffic Assessment

The existing volumes in **Figure 6** were analyzed using Synchro Version 10 software. The printouts for unsignalized intersections are based on HCM outputs and the results for signalized intersections are based on Synchro so that queues and more detailed information are provided. The detailed results are provided in **Appendix B** and summarized in **Table 1**. The analysis reflects the existing signal timing plans provided by the City of Mississauga.

Based on the intersection capacity analysis, under the existing traffic conditions, the following observations are made:

- The existing signalized intersection of the Queen Street S/Britannia Road W is currently operating at acceptable level of service based on overall intersection operation. There are some critical movements due to higher delay, however, the v/c ratios are only 85% or less. This is due to higher traffic volumes demand for this movement.
- The existing James Street/Queen Street S unsignalized intersection is expected to operate at acceptable levels of service during both the morning and afternoon peak hours, with maximum delay of 25 seconds per vehicle.
- The existing Queen Street S/Ellen Street/Private Access unsignalized intersection is currently operating at acceptable levels of service, with maximum delay of 36 seconds per vehicle.

The analysis indicates that no improvements are required under the existing conditions at this time.

Table 1 – Existing Levels of Service

Intersection	Key Movement	Weekday AM Peak Hour			Weekday PM Peak Hour			Available Storage Length (m)
		LOS (v/c)	Delay (s)	Queue 95 th (m)	LOS (v/c)	Delay (s)	Queue 95 th (m)	
Queen Street S/ Britannia Rd W (Signalized)	Overall	C (0.76)	32		D (0.85)	38		
	EB – L	B (0.43)	12	39	C (0.57)	29	39	130
	EB – TR	C (0.74)	27	255	C (0.54)	25	154	460
	WB – L	B (0.46)	19	24	B (0.37)	16	28	60
	WB – T	B (0.36)	19	91	C (0.74)	33	266	260
	WB – R	A (0.24)	7	29	A (0.13)	9	20	40
	NB – L	F (0.72)	88	53	E (0.84)	71	67	40
	NB – TR	E (0.67)	61	89	E (0.65)	56	88	150
	SB – L	E (0.76)	70	56	E (0.85)	70	73	65
SB – T	D (0.54)	52	104	E (0.72)	64	125	760	
SB – R	A (0.30)	8	17	B (0.43)	17	34	65	
Queen Street S/ Ellen Street (Unsignalized)	EB – LTR	C (0.02)	23	0	E (0.07)	36	2	15
	WB – LTR	C (0.17)	23	5	D (0.27)	34	8	90
	NB – LTR	A (0.00)	0	0	A (0.00)	0	0	160
	SB – LTR	A (0.02)	1	0	A (0.01)	0	0	150
Queen Street S/ James Street (Unsignalized)	EB – LR	C (0.04)	20	1	C (0.05)	25	1	85
	NB – TL	A (0.00)	0	0	A (0.01)	0	0	150
	SB - TR	A (0.29)	0	0	A (0.34)	0	0	150
James Street/ William Street (Unsignalized)	WB – LR	A (0.01)	9	0	A (0.01)	9	0	85
	NB – TR	A (0.01)	0	0	A (0.01)	0	0	150
	SB - TL	A (0.00)	0	0	A (0.00)	0	0	150

3.0 TRANSPORTATION PLANNING CONTEXT IN THE AREA

3.1. Land Use Context

A comprehensive review of the general area indicates that there are wide range of land uses and facilities available, which includes: Mississauga Road/Hwy 401 employment area, Streetsville GO Station (1.4 km south), Streetsville business area (1.0 km south) with banks, restaurants and grocery stores, community centres and elementary schools.

3.2. Transportation Planning Context

The proposed development is located adjacent to Routes 44 Mississauga, 39 Britannia, 10 Bristol-Britannia, 87 Meadowvale-Skymark and Route 43 Matheson-Argentia. In addition, the site is located about 5.5 km from Hurontario Street, approximately 25-minute bike ride. Residents can connect with the future Hurontario LRT via Route 39 Britannia and/or Route 10 Bristol-Britannia.

The proposed development is also located about 1.4 km to the existing Streetsville GO Train Station (or 6-minute bike ride). In addition, the area is also serviced by well-connected network of sidewalk and cycling facilities.

A comprehensive review of the area indicates that the area is currently servicing by excellent existing land uses, active transportation network and transit network. This will encourage other modes of transportation such as walking, cycling and public transit. Future residents living in the proposed development will have other ways to travel around, with less dependent on private automobile.

4.0 FUTURE BACKGROUND CONDITIONS

4.1. Analysis Horizon

For the purposes of this assessment, a five-year horizon (2023 to 2028) has been carried out for the study analysis. This is consistent with the City of Mississauga Traffic Impact Study Guidelines and background studies conducted in the area.

4.2. Future Background Corridor Growth

Nexttrans has received the growth rates from the City of Mississauga and Peel Region for the Britannia Road W and Queen Street S. The expected growth rates for Britannia Road W and Queen Street South are:

- Britannia Road W: 0.5% per annum (compounded) for both direction and for all periods
- Queen Street South:
 - Southbound AM – 1.0% per annum (compounded)
 - Northbound AM – 0.0% per annum (compounded)
 - Southbound PM – 0.5% per annum (compounded)
 - Northbound PM – 0.5% per annum (compounded)

Figure 7 illustrates the 2028 corridor background through traffic growth.

4.3. Background Development Applications

A full review of active developments within the study area was conducted based on the information extracted from the City of Mississauga Development Portal. The City also requested the following background developments to be included in the analysis:

- OZ 20-4 W11 - 1240 Britannia Road W: proposed 108 residential dwelling units
- OZ 17-20 W11 – 36, 38, 40, 44, 46 Main Street: proposed 26 residential dwelling units
- OZ 19-11 W11 – 64/66 Thomas St: proposed 239 residential dwelling units
- T 20-4 W 11 - 51 & 57 Tannery Street and 208 Emby Drive: proposed 142 residential dwelling units
- T 11-006 & OZ 16-11 W11 – 5155 Mississauga Rd: five commercial/retail units and 10 residential dwelling units
- OZ 20-11 W11 – 86 Thomas Street: proposed 10 residential dwelling units
- CDM 20-7 W11 – 80 Thomas Street: proposed 194 residential dwelling units
- SP 20-114 W11 – 66 Queen St S: proposed 10 residential dwelling units

For the purposes of this assessment, the background development traffic volumes were extracted from the available Transportation Impact Study in support of the proposed development noted above (**Appendix C**).

For those background developments that traffic impact studies are not available, site generated trips were estimated using ITE Trip Generation Manual 10th Edition and trip distribution/assignment using 2016 TTS data and existing traffic turning movements in the area. **Figure 8** illustrates the background development traffic volumes in the study area.

Figure 7 – 2028 Corridor Background Through Traffic Growth (Balanced)

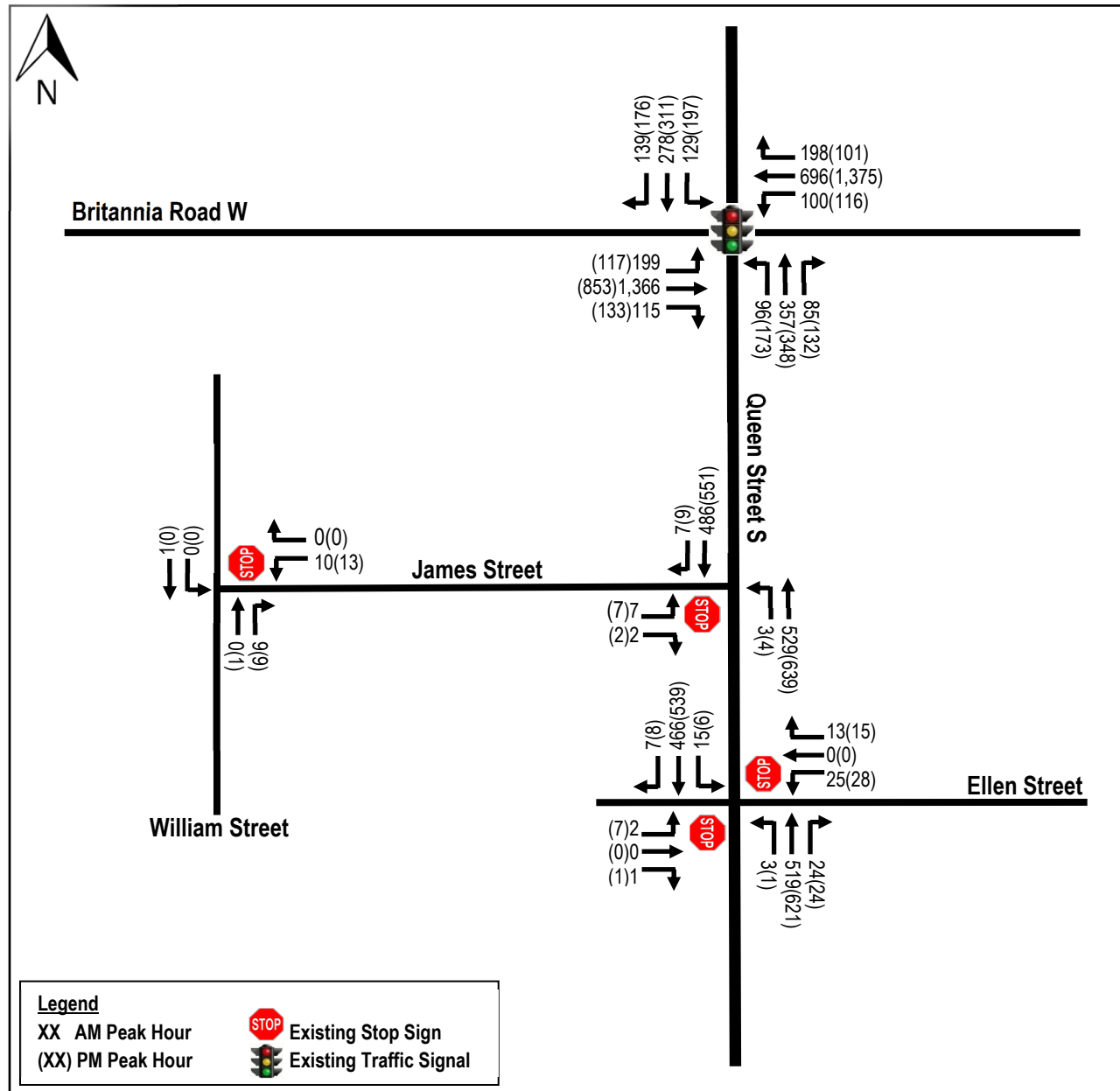

4.4. Future Background Traffic Assessment

The estimated 2028 future background traffic volumes are illustrated in **Figure 9** (background corridor growth + background development traffic), and were analyzed using Synchro Version 10 software. The detailed calculations are provided in **Appendix D** and summarized in **Table 2**.

Figure 8 – Background Development Traffic Volumes

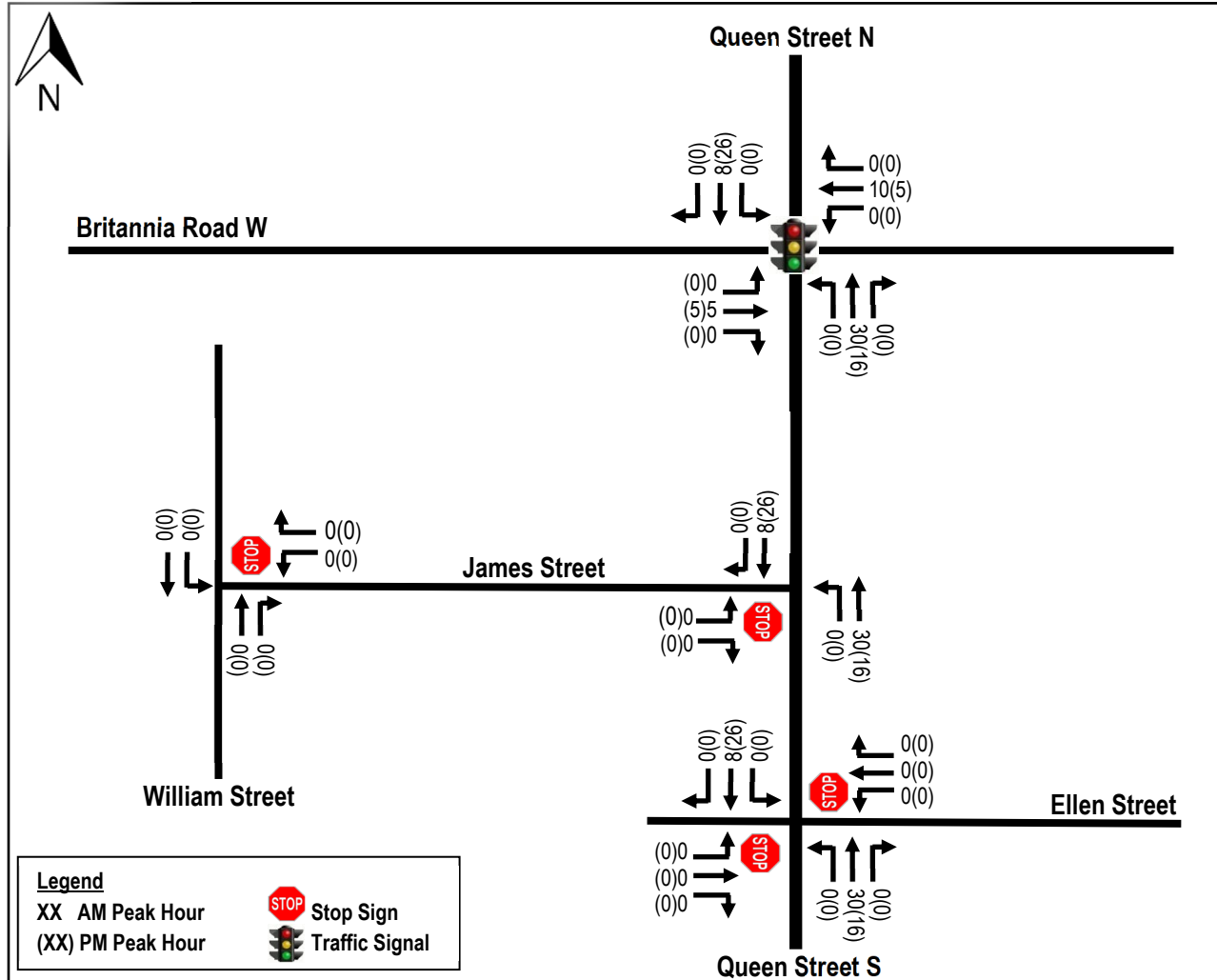

Based on the intersection capacity analysis, under the future background traffic conditions, the following observations are made:

- The existing signalized intersection of the Queen Street S/Britannia Road W is expected to operate at acceptable level of service based on overall intersection operation. There are some critical movements due to higher delay such as the northbound left turn, however, the maximum v/c ratio is only 0.87 or less and the queue slightly exceed the available storage length. This is due to higher traffic volumes demand for this movement. It is anticipated that with an increase in green time for the northbound left turn, this movement is expected to operate better. For the purposes of this assessment, Nextrans has optimized the signal timing plan to demonstrate that this movement can be improved without expensive construction costs to the City. The proposed signal timing plan is provided below:

AM Peak

Splits and Phases: 3: Queen Street S/Queen Street N & Britannia Road W

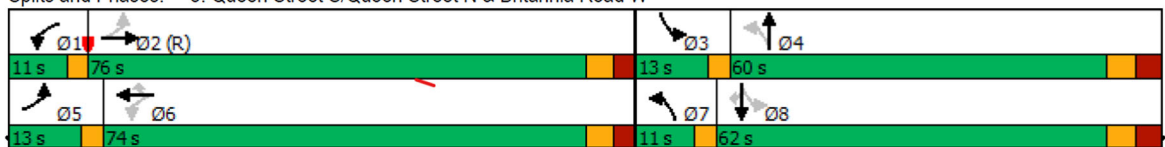

2028 Future Background AM Peak 4:14 pm 01-17-2023 Baseline

Synchro 10 Light Report

PM Peak

Splits and Phases: 3: Queen Street S/Queen Street N & Britannia Road W

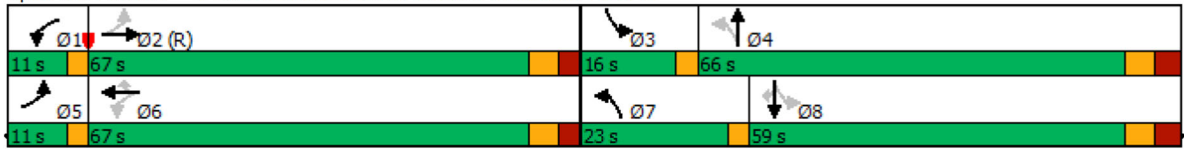

2028 Future Background PM Peak 4:44 pm 01-17-2023 Baseline

Synchro 10 Light Report

- The existing James Street/Queen Street S unsignalized intersection is expected to operate at acceptable levels of service during both the morning and afternoon peak hours, with maximum delay of 28 seconds per vehicle.
- The existing Queen Street S/Ellen Street/Private Access unsignalized intersection is currently operating at acceptable levels of service, with maximum delay of 43 seconds per vehicle.

The analysis indicates that no improvements are required under this horizon year.

Figure 9 – 2028 Future Background Traffic Volumes

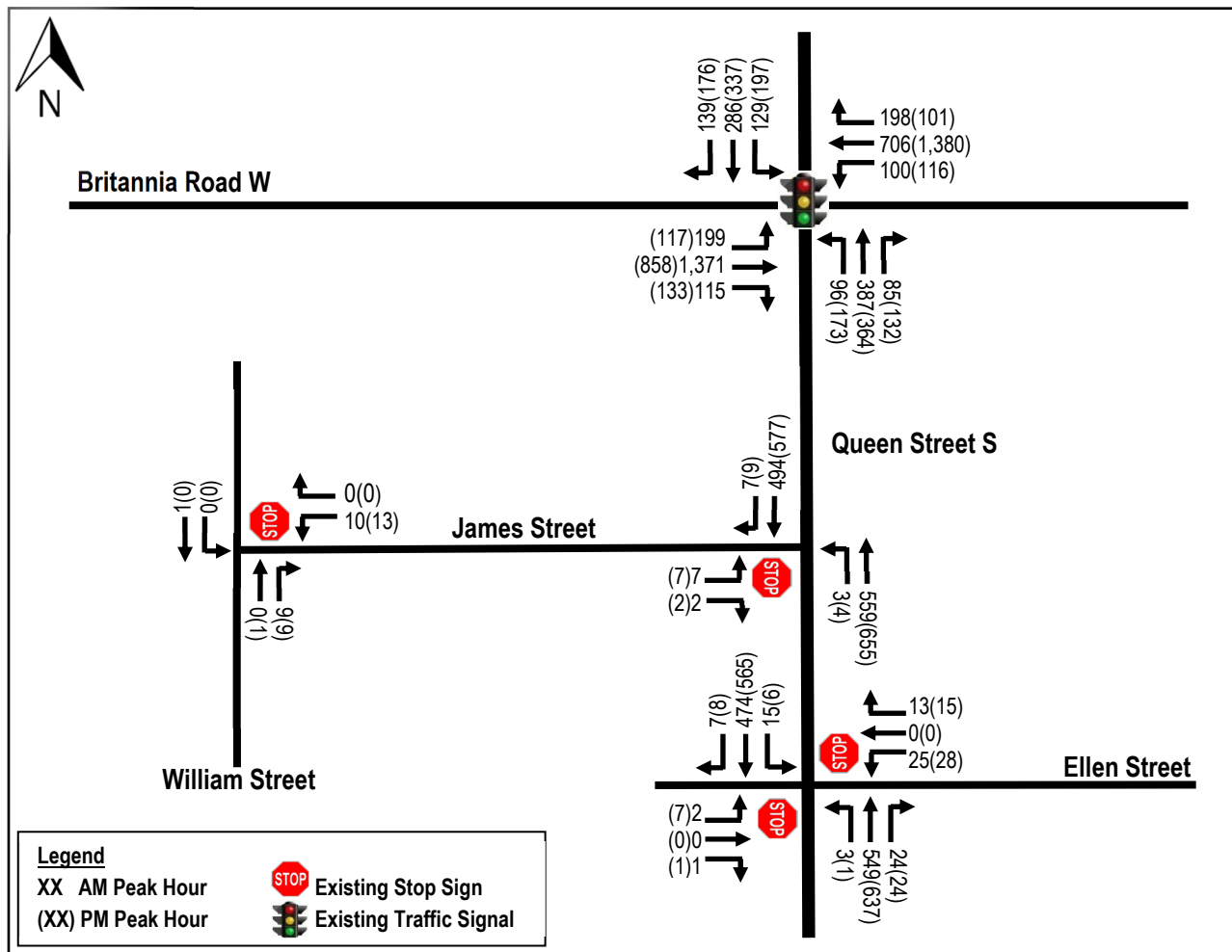

Table 2 – 2028 Future Background Levels of Service

Intersection	Key Movement	Weekday AM Peak Hour			Weekday PM Peak Hour			Available Storage Length (m)
		LOS (v/c)	Delay (s)	Queue 95 th (m)	LOS (v/c)	Delay (s)	Queue 95 th (m)	
Queen Street S/ Britannia Rd W (Signalized)	Overall	C (0.79)	34		D (0.87)	40		
	EB – L	B (0.45)	13	40	D (0.64)	44	47	130
	EB – TR	C (0.79)	30	280	C (0.58)	28	170	460
	WB – L	C (0.51)	26	32	B (0.42)	18	31	60
	WB – T	B (0.38)	20	99	D (0.80)	37	301	260
	WB – R	A (0.24)	8	31	A (0.14)	10	20	40
	NB – L	F (0.75)	93	54	E (0.87)	75	65	40
	NB – TR	E (0.69)	61	95	D (0.64)	53	91	150
	SB – L	E (0.76)	69	56	E (0.82)	63	73	65
	SB – T	D (0.57)	52	112	E (0.74)	63	137	760
SB – R	A (0.29)	7	17	B (0.41)	17	34	65	
Queen Street S/ Britannia Rd W (Signalized)	Overall	C (0.80)	35		D (0.86)	41		
	EB – L	B (0.46)	15	44	D (0.66)	49	54	130
	EB – TR	C (0.80)	32	314	C (0.63)	33	186	460
	WB – L	C (0.54)	31	36	C (0.46)	23	35	60
	WB – T	C (0.40)	22	106	D (0.86)	44	321	260
	WB – R	A (0.25)	10	35	A (0.14)	8	16	40
	NB – L	D (0.59)	54	38	D (0.66)	43	53	40
	NB – TR	E (0.64)	58	91	D (0.54)	45	82	150
	SB – L	E (0.70)	61	49	D (0.72)	47	61	65
	SB – T	E (0.71)	65	119	E (0.74)	63	137	760
SB – R	A (0.34)	9	18	B (0.40)	12	28	65	
Queen Street S/ Ellen Street (Unsignalized)	EB – LTR	D (0.02)	26	0	E (0.09)	43	2	15
	WB – LTR	D (0.19)	26	5	E (0.32)	41	10	90
	NB – LTR	A (0.00)	0	0	A (0.00)	0	0	160
	SB – LTR	A (0.02)	1	0	A (0.01)	0	0	150
Queen Street S/ James Street (Unsignalized)	EB – LR	C (0.04)	22	1	D (0.06)	28	2	85
	NB – TL	A (0.00)	0	0	A (0.00)	0	0	150
	SB - TR	A (0.32)	0	0	A (0.37)	0	0	150
James Street/ William Street (Unsignalized)	WB – LR	A (0.01)	9	0	A (0.01)	9	0	85
	NB – TR	A (0.01)	0	0	A (0.01)	0	0	150
	SB - TL	A (0.00)	0	0	A (0.00)	0	0	150

5.0 SITE TRAFFIC

5.1. Proposed Development

Currently, the subject site is occupied by several residential properties, some businesses and a storage yard. The current development proposal consists of two buildings of different heights (ranging from 2-8 storeys) with a total of 232 residential dwelling units, as well as a ground related non-residential use of 554.3 m² gross floor area. The 2016 Transportation Tomorrow Survey (TTS), the *Trip Generation Manual, 11th Edition* published by the Institute of Transportation Engineers (ITE) and information was reviewed to estimate the site trip distribution and trip generation for the proposed development.

5.2. Modes of Travel Assessment in the Area

Table 3 summarizes the travel mode split information based on the review of the 2016 Transportation Tomorrow Survey data for Traffic Zones 3715, 3718 and 3836. The 2016 TTS data extraction is included in **Appendix E**.

Table 3 – Modal Split based on 2016 TTS Data for Traffic Zones

Time	Trips Made by Traffic Zones				
	Auto Driver	Auto Passenger	Transit	Cycle	Walk
AM Peak Period (6:00Am – 9:00AM)	68%	14%	12%	0%	6%
PM Peak Period (4:00PM – 7:00PM)	74%	13%	9%	1%	3%

Based on the information above, the non-auto mode of transportation (transit + walking + carpooling) accounts for 32% during the morning peak period and 26% during the afternoon peak period.

Although this is a great trend, however, the auto driver mode is still very high, which is not sustainable and does not meet the sustainable objective of the City Official Plan policies and directions. In addition, there is none or very little bicycle trips, despite there are existing cycling facilities.

For the purposes of this assessment, no modal split will be applied to the proposed development. This assumption is conservative given the existing non-auto modal split is 32% and 26% for the morning and afternoon peak periods, respectively, based on the 2016 TTS data and local knowledge (well serviced by existing transit such as MiWay and GO Transit).

5.3. Site Trip Generation

The trip generation forecasts were undertaken using the information contained in the *Trip Generation Manual, 11th Edition* published by the Institute of Transportation Engineers (ITE). For the purposes of this assessment, the ITE Land Use Code (LUC) 221 “Multifamily Housing Mid-Rise General Urban/Suburban” fitted curve equations have been utilized for the proposed development. The site trip generation is summarized in **Table 4**. It should be noted that the proposed non-residential component is very small (only 554.3 m² gross floor area) which is intended to serve the proposed development and surrounding community within a walking or biking distance. It is no expected to generate any auto trips. Given that Nextrans is using more conservative rates (Mid-rise instead of Mid-rise with first floor commercial), therefore, no trips will be estimated for the non-residential component.

Table 4 – Site Trip Generation

ITE Land Use	Magnitude (units)	Parameters	Morning Peak Hour			Afternoon Peak Hour		
			In	Out	Total	In	Out	Total
Multifamily Housing (Mid-Rise) LUC 221 General Urban/Suburban	232	Trip Rates AM - T = 0.44*(X) - 11.61 PM - T = 0.39*(X) + 0.34	0.09	0.30	0.39	0.24	0.15	0.39
		Vehicle Trips	21	69	90	56	35	91
		Trip Rates AM - T = 0.16*(X) - 2.42 PM - T = 0.10*(X) - 1.27	0.08	0.07	0.15	0.05	0.04	0.09
		Transit Trips	8	27	35	13	9	22
Total Site Trips			29	96	125	69	44	113

Based on the analysis noted above, the proposed development is expected to generate:

- 90 total two-way auto trips (21 inbound and 69 outbound) and 91 total two-way auto trips (56 inbound and 35 outbound) during the AM and PM peak hours, respectively; and
- 35 total two-way transit trips (8 inbound and 27 outbound) and 22 total two-way transit trips (13 inbound and 9 outbound) during the AM and PM peak hours, respectively

5.4. Site Trip Distribution and Assignment

The 2016 Transportation Tomorrow Survey (TTS) data was reviewed for Traffic Zones 3620, 3621, 3694, 3697 and 3826 in order to estimate the general trip distribution for the proposed development. **Table 5** summarizes the planning district/traffic zones distribution based on the 2016 TTS data, with **Table 6** summarizing the site trip assignment based on the 2016 TTS data.

Table 5 – Trip Distribution for Residential Component

Mode	Mississauga	Toronto	Brampton	Caledon	York Region	Halton	Durham	Total
Auto	76%	7%	5%	1%	3%	8%	0%	100%

Table 6 – Site Trip Distribution

Direction	Percentage
North (via Queen Street S/Mississauga Road)	15%
South (via Queen Street S/Mississauga Road)	70%
East (via Britannia Road W/Hwy 401/Hwy 403)	7%
West (via Britannia Road W/Hwy 401/Hwy 403)	8%

Figure 10 illustrates the proposed development generated traffic volumes. It should be noted that the auto site trip distribution and assignment have been taken into consideration the 2016 TTS information, existing turning movements at the intersections and intersection operations.

6.0 FUTURE TOTAL TRAFFIC CONDITIONS

6.1 Future Total Traffic Assessment for Auto Mode

The estimated 2028 future total traffic volumes (future background traffic volumes plus site generated traffic volumes) are illustrated in **Figure 11**, and were analyzed using Synchro Version 10 software. The detailed calculations are provided in **Appendix F** and summarized in **Table 7**.

Figure 10 – Site Traffic Volumes

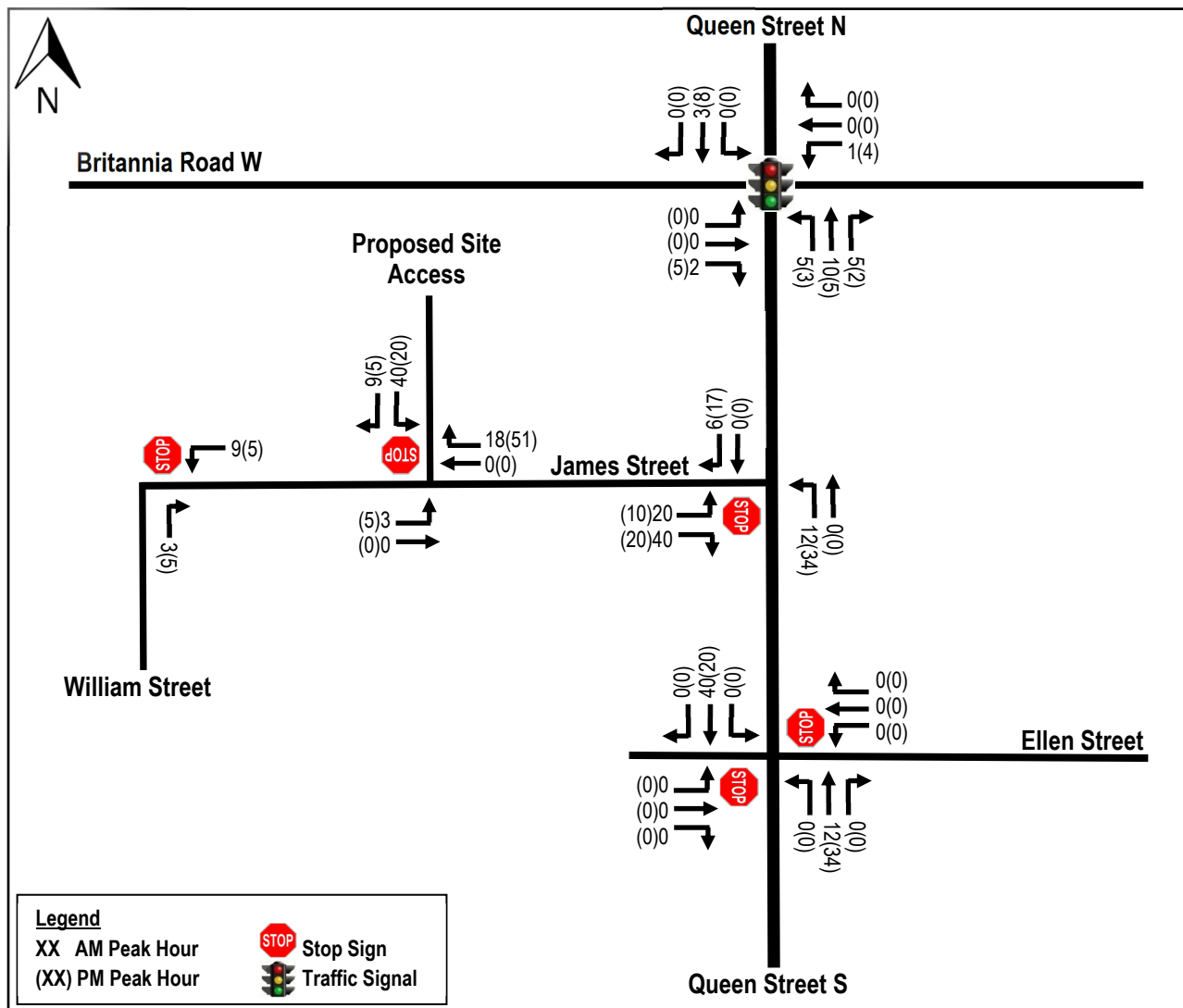
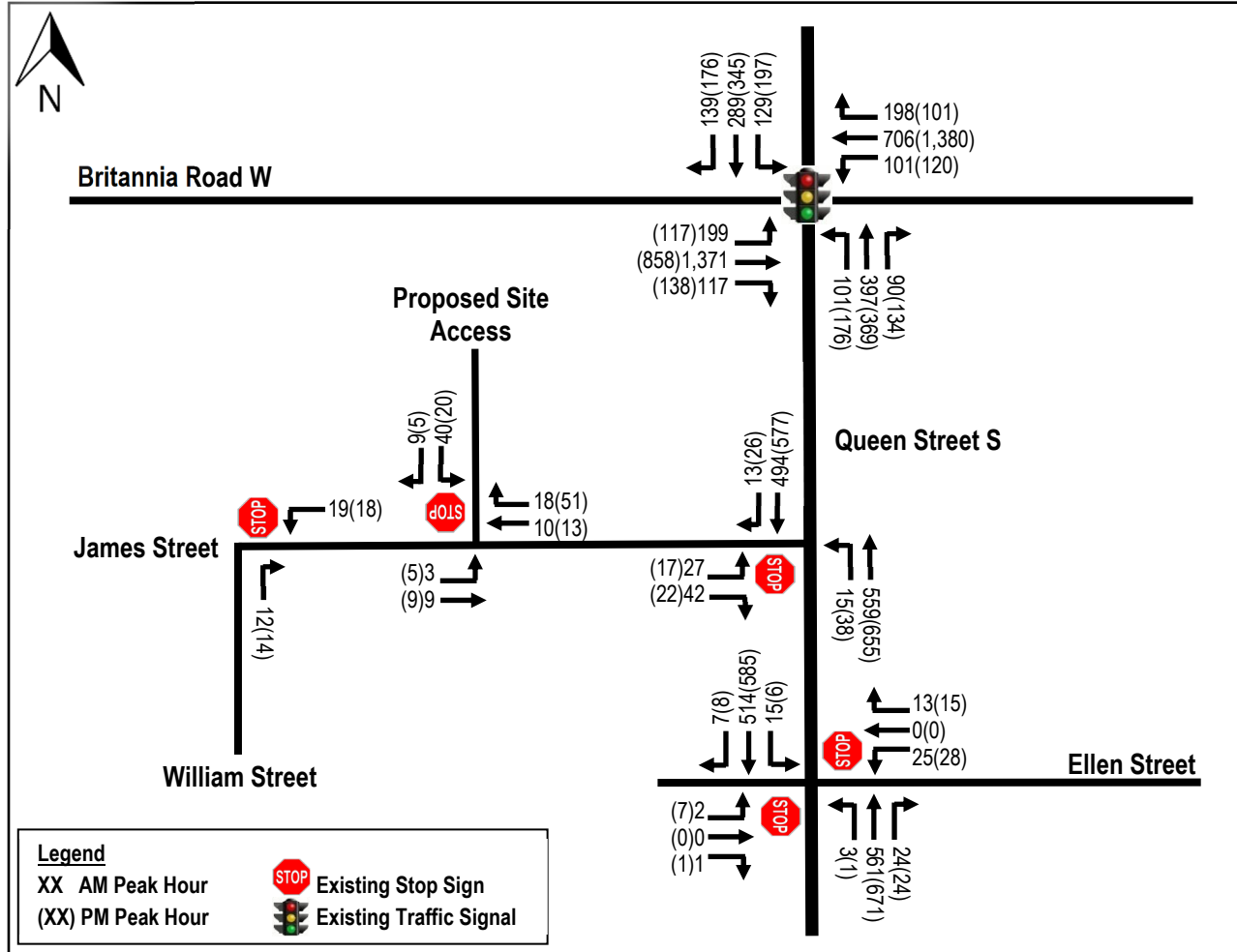

Figure 11 – 2028 Future Total Traffic Volumes



Based on the intersection capacity analysis, under the future total traffic conditions, the following observations are made:

- The existing signalized intersection of the Queen Street S/Britannia Road W is expected to operate at acceptable level of service based on overall intersection operation. There are some critical movements due to higher delay such as the northbound left turn, however, the maximum v/c ratio is only 0.89 or less and the queue slightly exceed the available storage length. This is due to higher traffic volumes demand for this movement. It is anticipated that with an increase in green time for the northbound left turn, this movement is expected to operate better. For the purposes of this assessment, Nextrans has optimized the signal timing plan to demonstrate that this movement can be improved without expensive construction costs to the City. The proposed signal timing plan is provided below:

AM Peak

Splits and Phases: 3: Queen Street S/Queen Street N & Britannia Road W

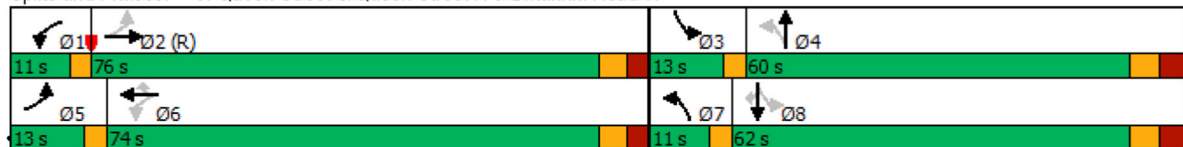

2028 Future Total AM Peak 4:14 pm 01-17-2023 Baseline

Synchro 10 Light Report

PM Peak

Splits and Phases: 3: Queen Street S/Queen Street N & Britannia Road W

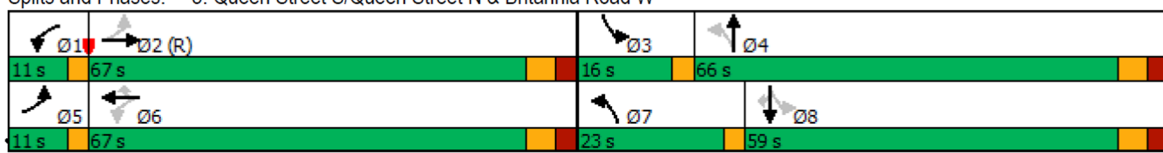

2028 Future Total PM Peak 4:44 pm 01-17-2023 Baseline

Synchro 10 Light Report

- The existing James Street/Queen Street S unsignalized intersection is expected to operate at acceptable levels of service during both the morning and afternoon peak hours, with maximum delay of 27 seconds per vehicle.
- The existing Queen Street S/Ellen Street/Private Access unsignalized intersection is currently operating at acceptable levels of service, with maximum delay of 48 seconds per vehicle.

The analysis indicates that no improvements are required under the future total conditions to accommodate the proposed development. The proposed development access is expected to operate at acceptable levels of service with minimum queues and delays, therefore, the proposed lane configurations are appropriate. The proposed lane configurations include: one inbound and one outbound (3.5 m width for each lane) and a shared westbound through/right and an eastbound shared through/left on James Street. No exclusive turning lanes are required at the proposed site access.

Table 7 – 2028 Future Total Levels of Service

Intersection	Key Movement	Weekday AM Peak Hour			Weekday PM Peak Hour			Available Storage Length (m)
		LOS (v/c)	Delay (s)	Queue 95 th (m)	LOS (v/c)	Delay (s)	Queue 95 th (m)	
Queen Street S/ Britannia Rd W (Signalized)	Overall	C (0.80)	34		D (0.89)	40		
	EB – L	B (0.45)	14	42	D (0.65)	45	48	130
	EB – TR	C (0.80)	31	287	C (0.59)	28	172	460
	WB – L	C (0.52)	28	34	B (0.44)	19	32	60
	WB – T	C (0.39)	21	101	D (0.80)	37	301	260
	WB – R	A (0.24)	9	31	A (0.14)	10	20	40
	NB – L	F (0.76)	93	56	E (0.89)	77	68	40
	NB – TR	E (0.69)	61	97	D (0.64)	53	92	150
	SB – L	E (0.76)	69	55	E (0.82)	62	72	65
	SB – T	D (0.57)	52	112	E (0.74)	63	139	760
	SB – R	A (0.29)	7	17	B (0.40)	17	35	65
Queen Street S/ Britannia Rd W (Signalized)	Overall	D (0.81)	35		D (0.87)	41		
	EB – L	B (0.46)	15	44	D (0.66)	49	56	130
	EB – TR	C (0.81)	33	316	C (0.64)	34	187	460
	WB – L	C (0.54)	32	36	C (0.48)	24	36	60
	WB – T	C (0.40)	22	107	D (0.87)	45	321	260
	WB – R	A (0.25)	10	36	A (0.15)	8	16	40
	NB – L	E (0.61)	55	39	D (0.67)	43	54	40
	NB – TR	E (0.66)	58	94	D (0.54)	45	83	150
	SB – L	E (0.72)	62	49	D (0.71)	47	60	65
	SB – T	E (0.71)	65	120	E (0.75)	63	140	760
	SB – R	A (0.34)	9	18	B (0.39)	13	29	65
Queen Street S/ Ellen Street (Unsignalized)	EB – LTR	D (0.02)	28	1	E (0.10)	48	3	15
	WB – LTR	D (0.20)	28	6	E (0.35)	47	11	90
	NB – LTR	A (0.00)	0	0	A (0.00)	0	0	160
	SB – LTR	A (0.02)	1	0	A (0.01)	0	0	150
Queen Street S/ James Street (Unsignalized)	EB – LR	C (0.24)	20	7	D (0.20)	27	6	85
	NB – TL	A (0.02)	0	0	A (0.05)	1	1	150
	SB – TR	A (0.32)	0	0	A (0.38)	0	0	150
James Street/ William Street (Unsignalized)	WB – LR	A (0.05)	9	1	A (0.02)	9	1	85
	NB – TR	A (0.00)	0	0	A (0.01)	0	0	150
	SB – TL	A (0.00)	0	0	A (0.00)	0	0	150
James Street/ Site Access (Unsignalized)	EB – TL	A (0.00)	2	0	A (0.00)	3	0	20
	WB – TR	A (0.02)	0	0	A (0.04)	0	0	50
	SB – LR	A (0.06)	9	2	A (0.03)	9	1	50

6.2. Potential Mitigation Measures

Potential mitigation measures include:

- The City requires all new developments in the area to implement Transportation Demand Management measures such as:
 - Parking reduction and management;
 - Pre-loaded PRESTO Cards to encourage residents taking transit;
 - Improve active transportation facilities such as providing more bicycle lanes instead of on-street parking
 - Not widen or adding any additional lanes on Britannia Road W or Queen Street S to accommodate better pedestrian and cycling crossing;
- The Region to optimize the signal timing for the Britannia Road W/Queen Street S intersection to reflect the future traffic volumes at the intersection. No physical improvements are required for this intersection under this horizon.

6.3. Active Transportation Assessment

Walking

Under the existing conditions, sidewalks are available on both sides of Britannia Road W along the frontage of the proposed development. Sidewalks are also available on both sides of Queen Street S south of Britannia Road W. Sidewalk is only available on the north side of James Street, about 50 m west of Queen Street S. Sidewalks are currently not available on William Street south of James Street.

As part of the proposed development, sidewalks be provided at least on one side all of the internal roads to accommodate pedestrian circulation. These sidewalks will be connected to Queen Street S and James Street, where appropriate. **Figure 12** illustrates the proposed internal sidewalk locations.

Cycling

Under the existing conditions, based on site visit and a review of the City's Cycling Map, there are no dedicated bicycle lanes in the immediate area, however, dedicated cycling lanes are available on Tenth Line and Bristol Road W and a short section of Queen Street S south of Erin Centre Blvd. There are several multi-use trails in the immediate area such as on the south side of Britannia Road W, Thomas Street west of Erin Mills, Winston Churchill Boulevard and a short section of Creditview Road.

As indicated under the existing condition assessment, the existing cycling network can be improved in the future as part of the City of Mississauga 2018 Cycling Master Plan to install more bicycle facilities on Queen Street S and Queen Street N in the area. This will encourage existing and future residents to use these facilities instead of driving single-occupant-vehicles.

As part of the proposed development, a total of 159 bicycle parking spaces will be provided on site. In addition, Nextrans recommends that the proposed development provides one bicycle repair station on site, at a convenient location that can be easily accessed by residents.

6.4. Transit Mode Assessment

The analysis indicates that the proposed development is expected to generate 35 total two-way transit trips (8 inbound and 27 outbound) and 22 total two-way transit trips (13 inbound and 9 outbound) during the AM and PM peak hours, respectively

As indicated in Section 2.4 of the Study, the proposed development is located adjacent to Routes 44 Mississauga, 39 Britannia, 10 Bristol-Britannia, 87 Meadowvale-Skymark and Route 43 Matheson-Argentia. In addition, the site is located

about 5.5 km from Hurontario Street, approximately 25-minute bike ride or 150-minute bus ride. Residents can connect with the future Hurontario LRT via Route 39 Britannia and/or Route 10 Bristol-Britannia. The proposed development is also located about 1.4 km to the existing Streetsville GO Train Station (or 6-minute bike ride).

The analysis indicates that the proposed development transit ridership can be easily accommodate by the existing excellent transit services and no improvements are required at this time to accommodate the proposed development.

Figure 12 – Proposed Internal Sidewalk Connections

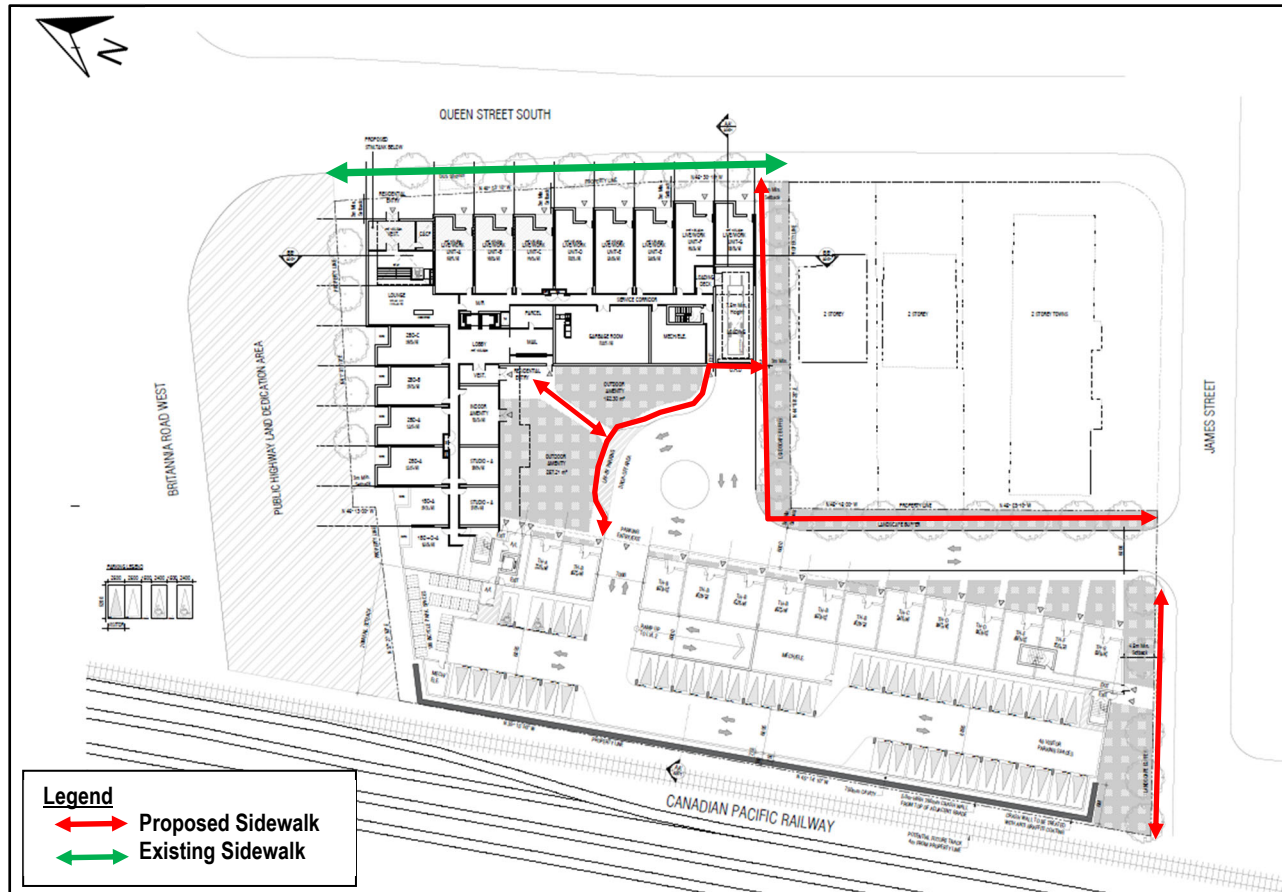

7.0 SITE PLAN REVIEW AND COMMUNITY CONCERNS

7.1.1. Proposed Development Access

Under the existing conditions, the existing residential properties have direct accesses onto Queen Street S. The remainder of the site has two full moves accesses onto James Street. Based on the City’s comments and concerns, the current development proposal will only provide one full moves access onto James Street, at approximately the same location as the existing access located immediately to the west of the existing townhomes, to accommodate the proposed development. All other existing accesses will be closed.

The analysis indicates that the proposed access onto James Street is expected to operate at acceptable levels of service with negligible queues or delays. Based on the intersection capacity analysis and site context, the proposed lane configurations include: one inbound and one outbound (3.5 m width for each lane) and a shared westbound through/right and an eastbound shared through/left on James Street. No exclusive turning lanes are required at the proposed site access.

7.1.2. Traffic Calming Review

Based on the transportation analysis and Nextrans' context review of the area, no traffic calming measures are required on Britannia Road W and Queen Street S as the posted speed limit is already low. In addition, based on Nextrans' site visit and review of the data collection videos, Nextrans did not notice any potential safety issues that need to be mitigated immediately during the peak hours.

Traffic calming measures are also not required on James Street because the existing and forecast traffic volumes are low, which will not cause any notable concerns. It should be noted that James Street is only 85 m from Queen Street S to William Street and has stop signs at both ends. Speeding will unlikely be an issue given such a short segment of the road.

In addition, the traffic calming measures for the internal condominium road is not required as the internal road has a very short segment leading directly into the proposed loading and drop-off/pick-up area. It is recommended that the condominium road pavement width should be designed as narrow as possible to discourage speeding and minimize pedestrian crossing.

7.1.3. Access Sightlines

Based on the City's comments and concerns, the current development proposal will only provide one full moves access onto James Street, at approximately the same location as the existing access located immediately to the west of the existing townhomes, to accommodate the proposed development.

Under the existing conditions, based on Nextrans' site visit, the existing access onto James Street is relatively flat and there are no horizontal curves or vertical curves on James Street. As the proposed development access will be located in the general location, it is not expected to have any potential sightline issues.

7.1.4. Operational Concerns

Based on the intersection capacity analyses and findings provided in this Study, no intersection operational concerns have been identified for the proposed development access and surrounding intersections such as the Queen Street S/James Street intersection.

In order to further reduce single-occupancy-vehicle trips to and from the proposed development, as well as to and from the area, vehicle parking supply for new development must be managed and reduced to discourage new residents owning private vehicles. Vehicle parking supply management is the most effective way to manage car ownership. In addition, transportation demand management measures and incentives similar to what have been identified in this report should be required and implemented by all new developments in the area.

7.1.5. Loading Requirement

The City of Mississauga Zoning By-law 0225-2007 was reviewed to determine the loading requirement for the proposed development. Based on this review, the proposed development is required to provide one on-site loading space. The proposed development meets this requirement AutoTURN software was used (Garbage and Fire Trucks) to generate vehicular turning templates to confirm and demonstrate the accessibility for the proposed development. The turning movement templates are illustrated in **Figures 15 and 16**.

7.1.6. Solid Waste Management

As indicated, a proposed loading space is provided at the south of the proposed building fronting onto Queen Street South. The garbage truck enters the proposed development via the site access onto James Street. The garbage truck can go straight into the garbage pick-up area. Once the operation is completed, the garbage truck would back up and then exit the site via the site access onto James Street. The analysis indicates that this operation is efficient and

acceptable. Based on Nextrans’ review of the Peel Region’s garbage pick-up schedule, the solid waste pick-up for this area is every Tuesday for green and blue bins, with garbage will be pick-up in alternate Tuesday.

7.2. Pavement Marking and Signage Plan

A preliminary pavement parking and signage plan has been prepared for the proposed development to assist the City in reviewing the site circulation, lane configurations and traffic control at the proposed development accesses and internal to the site. Once approved in principle, a final pavement marking and signage plan can be prepared and submitted to the City for the subsequent development application. **Figure 13** illustrates the preliminary proposed pavement marking and signage plan for the proposed development.

Figure 13 – Preliminary Proposed Pavement Marking and Signage Plan

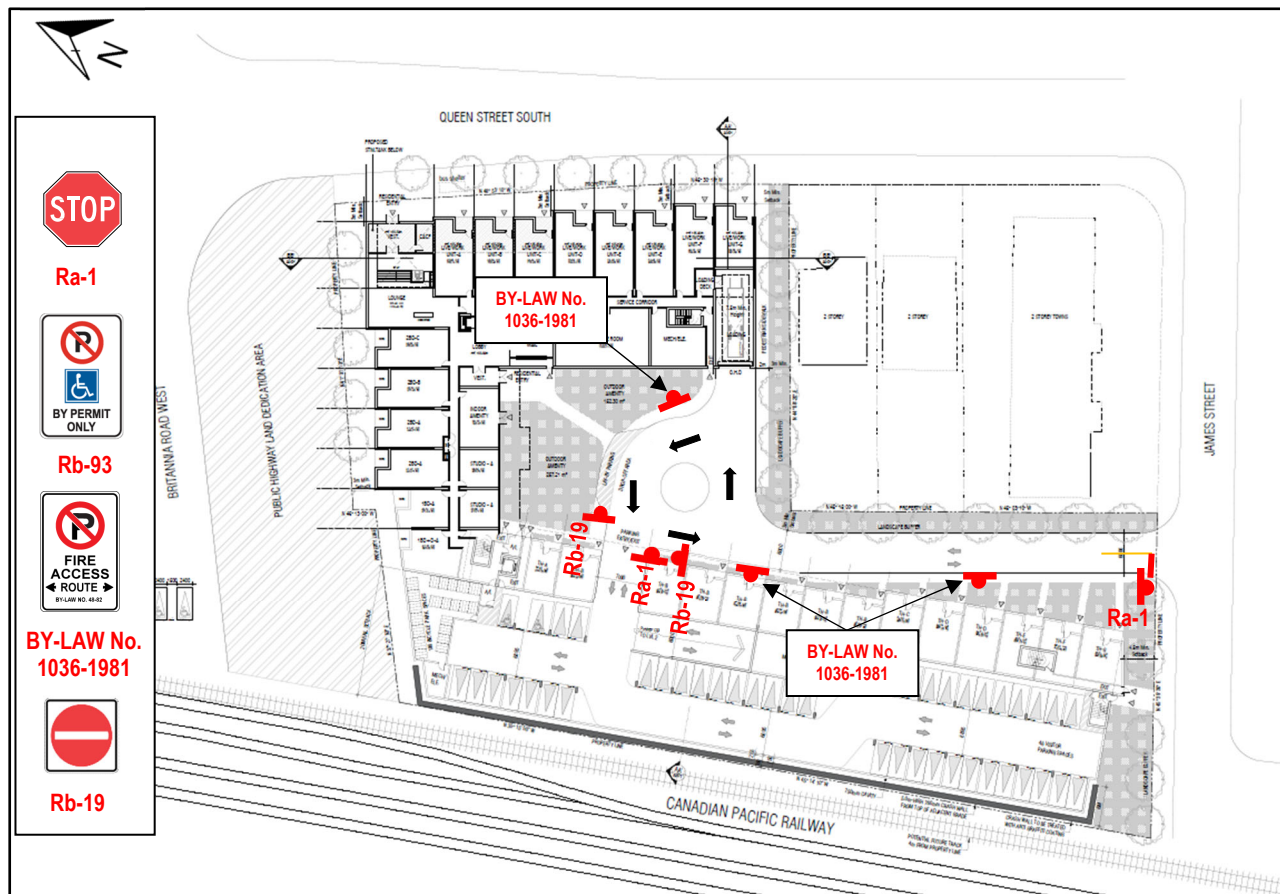

8.0 PARKING ASSESSMENT

8.1. Zoning By-law Vehicle Parking Requirement

The City of Mississauga Council has recently approved the new vehicle parking rate amendment to the existing Zoning By-law No. 0225-2007 (**Appendix G**). The proposed development is located within the new Precinct 2, with the blended rates of 0.9 space/unit for resident and 0.20 spaces/unit for visitor/ground related retail use, for the proposed condominium apartment land use category. **Table 8** below summarizes the vehicle parking requirements for the newly approved City of Mississauga Zoning By-law amendment.

Table 8 – City of Mississauga Zoning By-law Vehicle Parking Requirements

Unit Type	No. of Unit	Parking Rates	Parking Requirement
Residential	232 units	0.90 spaces/unit	209 spaces
Visitor/Non-residential	232 units	0.20 spaces/unit for visitor	46 spaces
Total			255 spaces
Accessible Parking Requirements			
Total no. of required visitor parking spaces	1-12 13-100	1 space 4% of the total	1 space 2 spaces
Total accessible parking requirements			3 spaces
Electric Vehicle Ready Parking Spaces			
Resident Parking	20% of the total required resident parking spaces		42 spaces
Visitor Parking	10% of the total required visitor parking spaces		5 spaces
Total EV ready parking space requirements			47 spaces

Based on the assessment noted above, the proposed development would be required to provide a total of 255 vehicle parking spaces, inclusive of residential, visitor and retail uses.

The proposed development parking rates should be further reduced as parking management is the best Transportation Demand Management measure. Based on the recommendations of this Study, the proposed development provides a total of 229 vehicle parking spaces, which represents about 6% reduction from the City's requirements.

8.2. Benefits of Vehicle Parking Reduction

8.2.1. Appropriate Parking Management is the best TDM Measure

Appropriate parking demand management is the best transportation demand management measure at this time because:

- Limited available parking spaces will encourage residents not to own a car
- It encourages residents to take other sustainable modes of transportation available in the area such as walking, cycling and public transit
- It maximizes transit ridership and therefore maximizes the impact of major transit infrastructure improvements

8.2.2. Support Alternative Modes of Transportation

Public Transit is an important mode of transportation for both short and longer distance trips to and from the proposed development. Based on Nextrans' review of the overall transportation network in the area, it is evident that the transportation network will be significantly transformed in the future with the following improvements:

- Hurontario Light-Rail-Transit (LRT);
- Dundas Bus-Rapid-Transit (BRT);
- Milton GO Line Expansion with all day two-way and 15-minute service frequency;
- Comprehensive active transportation network by the City and the Region; and
- Comprehensive Transportation Demand Management plan

As indicated in previous sections of this Study, the proposed development located adjacent to Routes 44 Mississauga, 39 Britannia, 10 Bristol-Britannia, 87 Meadowvale-Skymark and Route 43 Matheson-Argentia. In addition, the site is located about 5.5 km from Hurontario Street, approximately 25-minute bike ride or about 10-minute bus ride. Residents can connect with the future Hurontario LRT via Route 39 Britannia and/or Route 10 Bristol-Britannia. The proposed development is also located about 1.4 km to the existing Streetsville GO Train Station (or 6-minute bike ride and less than 10-minute bus ride). With the recent gas price increases and capital cost of owning a vehicle (new vehicle shortage due to supply chain problem), more residents will choose to use more convenient and effective modes of transportation such as public transit, walking and cycling.

8.3. Recommended Vehicle Parking Requirement for the Proposed Development

Given the reasons noted above, this area will be transformed into a major transportation mobility hub for all modes of transportation including excellent transit and active transportation. These modes of transportation are sustainable and cheaper than owning a private vehicle. These modes of transportation will also help reducing congestion and pollution in the area. The following are recommended parking rates (Table 9) for the proposed development, based on the parking justification provided in subsequent sections of this Study.

Table 9 – Recommended Vehicle Parking Rates for the Proposed Development

Unit Type	No. of Unit	Parking Rates	Parking Requirement
Residential	232 units	0.80 spaces/unit	186 spaces
Visitor/Non-residential	232 units	0.20 spaces/unit for visitor	46 spaces
Total			232 spaces
Accessible Parking Requirements			
Total no. of required visitor parking spaces	1-12	1 space	1 space
	13-100	4% of the total	2 spaces
Total accessible parking requirements			3 spaces
Electric Vehicle Ready Parking Spaces			
Resident Parking	20% of the total required resident parking spaces		37 spaces
Visitor Parking	10% of the total required visitor parking spaces		5 spaces
Total EV ready parking space requirements			42 spaces

Based on the recommended vehicle parking rates, the proposed development will provide a total of 239 vehicle parking spaces for both resident, visitor and non-residential components. This includes 193 residential vehicle parking spaces and 46 visitor/non-residential shared vehicle parking spaces.

The proposed development will also provide a minimum of 3 accessible spaces and 42 EV ready parking spaces.

9.0 VEHICLE PARKING JUSTIFICATION

9.1. Subject Site Strategic Location

The proposed development is located adjacent to Routes 44 Mississauga, 39 Britannia, 10 Bristol-Britannia, 87 Meadowvale-Skymark and Route 43 Matheson-Argentia. In addition, the site is located about 5.5 km from Hurontario Street, approximately 25-minute bike ride. Residents can connect with the future Hurontario LRT via Route 39 Britannia and/or Route 10 Bristol-Britannia. The proposed development is also located about 1.4 km to the existing Streetsville GO Train Station (or 6-minute bike ride).

9.2. Subject Site Walk Score

Nextrans has reviewed the walk score for the subject site using the information in www.walkscore.com website. Table 10 below summarizes the walk score for the subject site.

Table 10 – Walk Score for 2 Queen Street South

Mode	Score	Description
Walking	73	Very walkable – most errands can be accomplished on foot
Public Transit	47	Some transit – a few nearby public transportation options
Cycling	64	Bikeable – some bike infrastructure

The potential reasons the subject site is described as “some transit – a few nearby public transportation options” are because the walk score does not take into consideration of the future GO Expansion Program by Metrolinx that will

provide all-day two-way and 15-minute frequency service at the Streetsville GO Station. However, based on Nextrans' review of the area as indicated in other sections of this Study, there are many transit routes that has direct connections to the future Hurontario LRT such as bus routes 10 and 39.

9.3. Existing Mode Share

Table 11 summarizes the travel mode split information based on the review of the 2016 Transportation Tomorrow Survey data for Traffic Zones 3715, 3718 and 3836. The 2016 TTS data extraction is included in **Appendix E**.

Table 11 – Modal Split based on 2016 TTS Data for Traffic Zones

Time	Trips Made by Traffic Zones				
	Auto Driver	Auto Passenger	Transit	Cycle	Walk
AM Peak Period (6:00Am – 9:00AM)	68%	14%	12%	0%	6%
PM Peak Period (4:00PM – 7:00PM)	74%	13%	9%	1%	3%

Based on the information above, the non-auto mode of transportation (transit + walking + carpooling) accounts for 32% during the morning peak period and 26% during the afternoon peak period. Therefore, a recommended 6% reduction is justified just based on the existing trend.

As parking management is the best Transportation Demand Management measure and the best incentive to promote transit usage, less parking shall be provided by new developments in the area in order to increase the mode share targets set out by various policies and objectives in the City and the Region Official Plans, Transportation Master Plans and Provincial Growth Statement.

Proposed unit types lend itself to those who wish to live along active transit lines for accessibility without the need of a car. In addition, with no car ownership, it will help keep the housing and cost of living more affordable.

In the last several years, there were a substantial uptake and usage of electric scooters and e-bikes in the Greater Toronto Area due to high gas prices, vehicle capital costs due to vehicle production shortage, as well as extremely high auto insurance costs. This trend will continue to grow in the future with private vehicle affordability due to higher interest rates to purchase new vehicles.

Based on the information provided above, parking reduction for the proposed development is justified and must be implemented in order to achieve the sustainable policies and requirements.

9.4. City of Mississauga Parking Master Plan and Implementation Strategy (May 2019)

WSP has completed a Parking Master Plan and Implementation Strategy dated May 2019 for the City of Mississauga. The goals of the Strategy are: to improve the efficiency and effectiveness of current and future resources dedicated to parking, and to use parking as a tool to realize the city building objectives set out in the City's planning documents.

Source: <https://www.mississauga.ca/wp-content/uploads/2020/01/29100838/Mississauga-PMPIS-Report-AODA.pdf>

The Parking Vision Statement was developed through extensive consultation with the public and relevant City divisions.

The Vision for Parking in the City is that parking policies and practices should consider parking as a valuable resource that influences city building, transportation choices and economic development, and provides an important service for residents and businesses. The City should strive to ensure a balance between parking provision and management to maximize support for Mississauga as a multi-modal city. Finally, the City should strive to ensure a fair distribution of parking costs.

The Study recommended that the City requires all future parking policy and practices to be strategically consistent with the vision statement.

In the subsequent WSP Parking Regulations Study, Policy Directions for Consultation, dated March 24, 2022 WSP provided proposed policy directions for minimum parking reductions:

"Minimums can be lowered through site-specific applications with a parking demand study that justifies lowering the required number of parking spaces."

"The City should continue to monitor parking demand and could make further changes in the future when additional transit and infrastructure supporting non-auto modes of travel are available to limit the potential oversupply of parking spaces."

As cited above, WSP advises that the City review site-specific parking reductions and notes that changes may be made when transit and supporting non-auto modes of travel are available.

The report also notes: "Parking minimums help regulate the baseline amount of parking required depending on land use and anticipated demand to control undesirable parking practices. When they are set to reflect actual parking demand, functional parking needs can be met." As discussed below, in Section 9.9 of this report, the underlying assumption of how WSP set the minimum parking rates based on demand has recently been found to be incorrect – and actually setting minimum parking rates at the level of demand translates to increased auto usage. This causal effect, and the recent “gold standard” control study that confirms this causal relationship, is discussed in more detail below in Section 9.9.

9.5. Housing Affordability and Crisis

The Greater Toronto Area, including the City of Mississauga, is currently facing a housing shortage and affordability crisis. Demand for new housing is high; especially during the COVID-19 pandemic. Once the pandemic is over, housing availability and affordability are expected to further decline. One component that increases the cost of new units in multi-storey buildings, is the requirement to provide a minimum rate of parking; even in areas well serviced by transit with historically low vehicle ownership and use rates. The cost of providing one underground parking space is in the range of \$48,000 to \$160,000 per space due to the aggregate impact of land costs, constructability, site constraints and other factors leading to high construction costs (*Source: City of Toronto Presentation: Review of Parking Requirements for New Development - Sept 2021*).

Furthermore, the more residential or visitor parking spaces that a proposed development has to provide, the more expensive the maintenance costs will be for the owners. Monthly maintenance cost for a parking space could be up to \$100 per month, on top of the capital costs of a parking space. The provision of less parking can reduce overall maintenance costs and result in lower housing costs/greater housing affordability.

9.6. Covid-19 Pandemic and Working from Home

As the COVID-19 pandemic is still impacting globally, in Canada, the Province of Ontario, and particularly, the City of Mississauga and Peel Region, this pandemic will permanently alter the way people work and travel in the future. For example, since the lockdown in March, 2020, the City experienced a significant decrease in peak hour travel on both private vehicles and other trips in general. This is due to the fact that many office employees and employers elected to work from home. This trend has continued into November 2022; at the time of the preparation of this Study.

Based on various reporting from media, this working from home trend for office workers may continue even when the pandemic is over as both employees and employers have invested significantly in remote working equipment and infrastructures, as well as faster internet and online meeting platforms such as Zoom, Microsoft Teams and Skype for business.

9.7. A Reduction to the Minimum Vehicle Parking Requirements is Consistent with Provincial and Regional Direction

The Provincial Policy Statement, 2020 provides policy direction province-wide on land use planning and development to promote strong communities, a strong economy, and a clean and healthy environment. It includes policies which

encourage land use patterns that minimize the length and number of vehicle trips and support current and future use of transit and active transportation.

The Growth Plan (2019) contains policies related to reducing dependence on the automobile and promoting and supporting active transportation and transit. Discouraging auto-dependence requires that there are reasonable alternatives to cars available. All levels of government are making large investments to improve the transit system in Mississauga and the broader region which includes the future Hurontario LRT. The Region is working with the Province to ensure that areas near new stations develop in a transit-supportive way. Widely available automobile parking, mandated by parking minimums, supports continued widespread automobile use and puts the financial viability of the transit investments at risk. This is also addressed by the Growth Plan (2019) Policy 2.2.4.9 which says that "within all major transit station areas, development will be supported, where appropriate, by: c) providing alternative development standards, such as reduced parking standards."

9.8. High Residential Vehicle Parking Rates Result in More Car Ownership and More Driving While Reducing Transit Usage

Many municipalities have historically required new development projects to include parking, out of fear that if new residents are not provided with parking they will park around the local community and this will cause issues. The assumption here, behind both the policy and the pushback on reductions, is that people will always choose to drive, and the urban environment should be designed to accommodate that inevitable choice. But new research shows how that assumption is often backwards — offering the strongest evidence yet that parking doesn't just follow driving in cities, but can actually cause it. The new work comes from a group of urban planning scholars at UCLA and UC-Santa Cruz, led by Adam Millard-Ball, and has been published in an issue of the journal *Urban Studies*. Using an innovative and elegant study method, the researchers show clearly that "increased parking causes more car ownership and more driving while reducing transit use." They continue: "In summary, the evidence from our study robustly supports that urban residents' transportation behavior — but not their employment — is affected by local features of the built environment, and particularly so by parking." The conclusion underscores the importance of urban design in shaping behavior.

This new study distinguishes itself by finding a way to effectively (and ethically) randomize a population: San Francisco's housing lottery. In San Francisco, inclusionary zoning regulations typically require new developments with 10 or more residential units to provide affordable housing, which is offered to income-eligible households through a lottery. This is the gold standard for showing causation through a randomized trial.

In spring 2019 — pre-pandemic — the researchers mailed a travel behavior survey to housing lottery winners in 197 development projects across San Francisco. The short questionnaire, provided in four different languages, asked about typical travel mode (car, transit, bike, walking), car-ownership status, and employment status. Roughly 780 households responded.

When the researchers matched travel behavior to parking requirements, they found "a clear and substantive trend:" as parking supply rose, so did car-ownership. In buildings without any parking, only 38 percent of respondents owned a car. Car-ownership climbed as parking requirements increased, reaching 81 percent of respondents in buildings that required one parking space per housing unit. **Figure 14** illustrates the survey responses for car ownership by residential parking ratio.

Owning a car isn't the same as using it, but further analysis found a statistically significant relationship between parking supply and driving, too. Generally speaking, households that lived near public transit, or that had good walking or cycling access, tended to use those options more often than households that did not. But when it came to using transit, in particular, the effect of a building's parking ratio was "more than twice as large" as that of its transit access.

In other words, even in buildings with transit access, parking supply was the stronger pull — increasing driving behavior by the same amount it reduced transit use. When buildings provide ample parking, residents buy a car and drive. But when buildings have transit access without easy parking, residents use other ways to get around.

“Where streets are relatively walkable and transit service is frequent,” writes the research team, “parking emerges as the key factor shaping household travel behavior.”

Figure 14 – Survey Responses for Car Ownership by Residential Parking Ratio

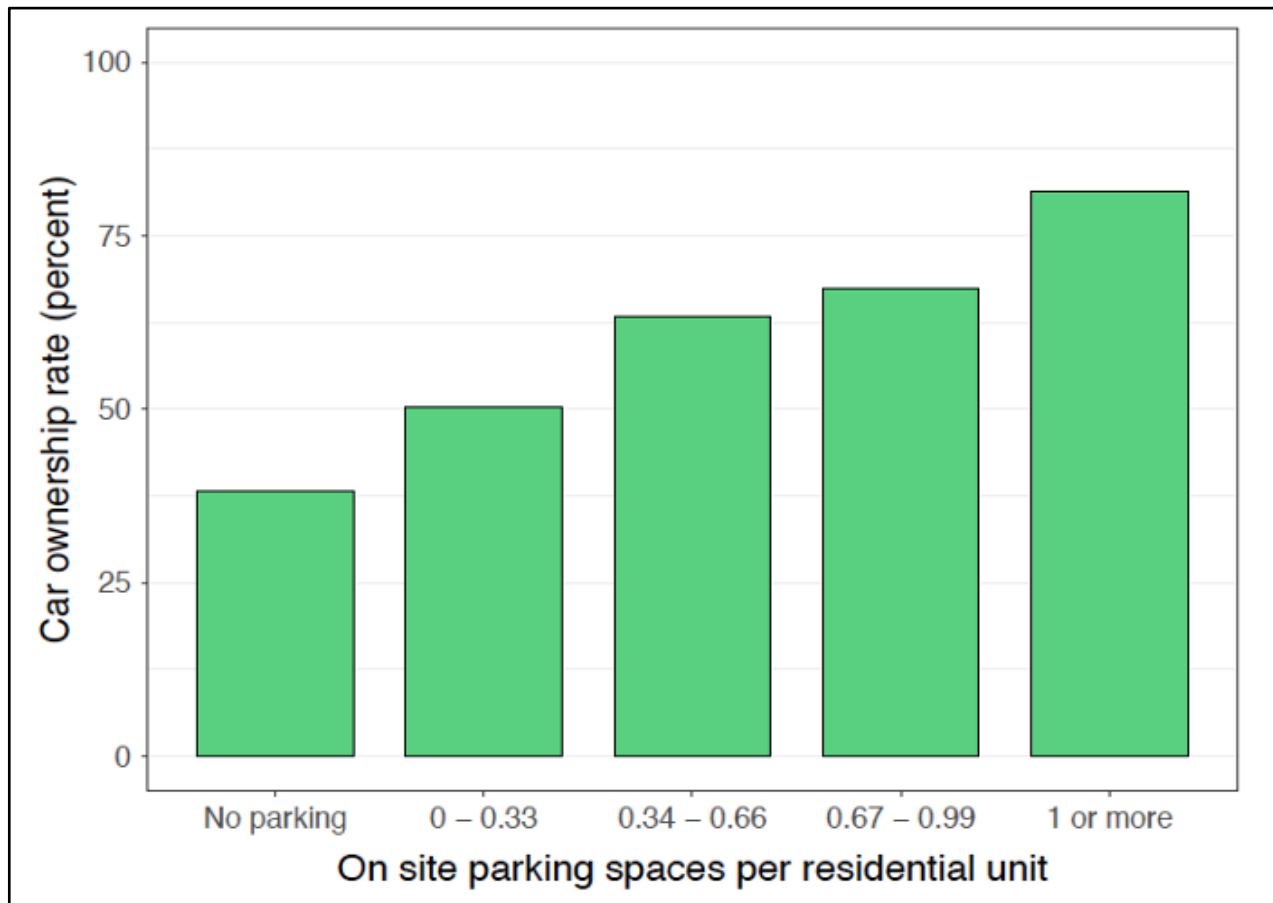

One final, critical result: the researchers found no connection at all between parking supply and full-time employment status. That’s very important, because it suggests that reducing or eliminating parking spaces won’t negatively impact a household’s ability to keep a job, as is often feared.

The study represents a significant step forward for urban mobility policy and offers robust, conclusive and definitive evidence through a controlled study that parking minimums do indeed cause more driving. In alignment with this study, San Francisco eliminated parking minimums. And likewise, supported by this study, San Jose; Cambridge, Massachusetts; Culver City, California; Lexington, Kentucky; and Anchorage, Alaska have all eliminated parking minimums as of October of this year.

The results of this “gold standard” study were published after the preparation of the parking background study, Parking Master Plan and Implementation Strategy, May 2019, prepared by WSP which was used to inform the current Mississauga parking rates implemented December 6, 2021. Had this study proving the direct causation between providing a 0.8 spaces/unit and driving been available before the preparation of their report, it is expected that WSP would have recommended a much lower minimum parking rate nearing 0.3 to 0.4 spaces/unit and / or recommended a complete elimination of minimum rates in areas well-served by transit.

(Source: https://people.ucsc.edu/~jwest1/articles/MillardBall_West_Rezaei_Desai_SFBMR_UrbanStudies.pdf).

9.9. A Reduction to the Minimum Vehicle Parking Requirements Increases the Supply of Affordable Housing

Increasing the supply of affordable housing is a Provincial, Region of Peel and City of Mississauga priority. Parking minimums increase the cost of housing, by adding to construction costs which may in turn be passed on to residents. Typical underground parking costs in the GTA Complex conditions can add up to \$200/ft² more (*Source: AltusGroup - 2021 Canadian Cost Guide*). This translates to a \$48,000 - \$160,000 increase in the cost of housing. There are also short term and long-term maintenance/condo fees related to this parking. The ability to avoid the cost of parking by choosing housing without parking is limited by the existence of minimum parking requirements. Many municipalities in Ontario, Canada and abroad have acknowledged that current automobile parking standards represent a barrier to the City achieving its housing vision and have recently made decisions to severely reduce and / or eliminate parking minimums in areas well-served by transit:

City of Toronto

The City of Toronto has recognized that the requirement of excessive parking is a barrier to achieving the City's housing needs and objectives, auto-independence and promoting other modes of transportation such as public transit, walking and cycling. In March, 2022, the City of Toronto Council has adopted Zoning By-Law Amendments that removed the minimum parking requirement for residential component, instead, the Zoning By-law only speaks to the maximum parking rates that can be applied to a proposed residential development (By-law 89-2022 - removal of minimum residential parking space requirements and the establishment of residential parking maximums provided in Provision 18).

City of Edmonton

In June of 2020, the City of Edmonton Council voted unanimously to change the Zoning By-law with no minimum vehicle parking requirements. Maximum parking requirements will remain in effect downtown and are being expanded in transit-oriented developments and main street areas.

Other Cities in the United States

A number of American cities have eliminated minimum parking requirements on new developments:

- City of Buffalo, 2017
- City of Minneapolis, 2021
- City of San Diego, 2021
- City of San Jose, 2022
- City of San Francisco, 2018
- City of Portland,
- City of Berkeley, 2021
- City of Sacramento, 2021
- City of South Bend, 2021
- City of Alameda, 2021
- City of Richmond, 2021
- City of St. Paul, 2021
- City of Emeryville, 2019
- City of Raleigh, 2022
- City of Ann Arbor, 2022
- City of Canandaigua, 2020
- City of Jackson, 2021
- Culvert City, 2022
- City of Dunwoody, 2019
- City of Lexington, 2022
- City of Albemarle, 2021

- City of Hudson, 2019

City of Vaughan

The City of Vaughan Council passed Zoning By-law 001-2021 in October of 2021 (part of the By-law is being appealed to the LPAT), that includes a reduction in the minimum number of parking spaces required. Under the previous Zoning By-law No. 1-88, a minimum of 1.5 parking spaces per dwelling unit was required. The City's new Zoning By-law No. 001-2021 will include a notable reduction in parking rates in the Vaughan Metropolitan Centre (VMC) area, with a rate of only 0.55 spaces/unit (0.40 spaces/unit for residents and 0.15 spaces/unit for visitors). While the Zoning By-law rates have been set, we do know that lower rates than the new by-law rates have been approved in the VMC. It should be noted that the VMC shares similar characteristics with the subject site's area with significant transit investments by all levels of government. The subject site is currently well-served by the existing Mississauga City Transit Terminal, and it will be well-served by the future Hurontario LRT Line, which provides connection to the Cooksville GO Train Station, future Dundas BRT and future Lakeshore BRT.

City of Ottawa

The City of Ottawa Zoning By-Law parking requirements were revised to eliminate minimum parking requirements for developments within 600 metres of an LRT station, and similar to the City of Toronto, it adopts a maximum allowable parking rates for new development. This is to support the new major transit investment of the Confederation Line which opened in December 2019 and services through the downtown area. New residential developments near LRT stations are not required to provide any resident parking and only require to provide visitor parking at a rate of 0.10 spaces per unit.

North Oakville (Town of Oakville)

The Town of Oakville Council passed Zoning By-Law No. 2009-189 for the area of North Oakville. The Zoning By-law No. 2009-198 provides maximum allowable parking rates for new residential developments, such as apartment buildings with more than 4-storey (up to 1.25 spaces per dwelling unit for residents plus 0.20 for visitors). This Zoning By-Law is in line with the North Oakville Parking Strategy study, prepared in November, 2009, which provided the Town with a strategy to create a pedestrian friendly and a more transit-oriented suburb by encouraging a more efficient use of private and public parking resources and provide a reduced parking requirement to reflect transit planning goals.

City of Brampton

The City of Brampton has adopted Zoning By-law Amendment No. 45-2021 to the Zoning By-law No. 270-2004 for the Downtown, Central Area and Hurontario/Main Street Corridor. The By-law states that, notwithstanding any minimum parking requirement prescribed in Sections 10.9.2(a), 10.9.3, 20.3.1 and 30.5, there shall be no minimum required parking for any use within the boundaries of Schedule B-7 (**Appendix I**).

This is a very encouraging provision to support and address housing affordability and shortage in the City of Brampton. This is also in-line with other jurisdictions in the GTA such as the City of Toronto as indicated above. Given that the proposed development is located adjacent to three rapid transit lines (Hurontario LRT, Milton GO Line and Dundas BRT further to the south). We recommend the proposed development have a much lower rate, or no minimum, similar to the City of Brampton and the City of Toronto, as presented in this Study.

The municipalities that have severely reduced and / or remove parking minimums have not re-imposed them, noting that they have been successful. They have found that the reduction to the minimum automobile parking requirements does not remove or prohibit parking in new developments but rather recognizes that parking minimums embedded in their prevailing zoning by-laws may not be nuanced enough or be updated frequently enough to be applicable in all situations and equitable access, such as for accessible parking, can still maintain. Specifically, the City of Toronto cited:

“.. the amount of parking that is required sorts itself out through market mechanisms. If someone wants a parking spot, they can get one through renting or purchasing a property that includes a parking spot. If developers realize they are unable to sell units without parking, parking will be provided.”

9.10. A Reduction to the Minimum Vehicle Parking Requirements Will Help Supporting Local Businesses

A lower parking rate can help to support local businesses and improve the overall vibrancy of the community. When tenants are encouraged to use alternative forms of transportation, they are more likely to walk or bike to local shops, restaurants, and other businesses. This can help to support the local economy and create a more vibrant and dynamic community. A study from London England found that implementing policies aimed at reducing auto-dependence and encouraging transportation alternatives to automobiles, increased retail spend by 30% in local town centres and on main streets. And over a month, people who walk to the main street spend up to 40% more than people who drive there.

(Source: <https://content.tfl.gov.uk/town-centres-report-13.pdf>).

This is consistent with other policy and design interventions implemented in other cities like the City of Toronto, New York City and Seattle. For example, the introduction of bike lanes, and the recent removal of parking minimums, on Vanderbilt Avenue, in New York City, led to a 102% increase in retail sales and, similarly, on Latona Avenue and 65 Street, in Seattle, a similar intervention increased retail sales by 400%.

(Source: <https://www.toronto.ca/wp-content/uploads/2019/11/8fd3-Bloor-Bike-Lane-Economic-Impact-Research-Summary-2019.pdf>).

9.11. A Reduction to the Minimum Vehicle Parking Requirements has a Number of General Benefits

A reduction in the minimum parking requirements which decreases vehicle trips and increases transit usage (as proven via the UCLA study above) also provides the following benefits:

- Reduced traffic congestion in the area. Refer to Section 3.2 (2016 TTS Mode Share) of this report which demonstrates that a reduction in vehicle parking reduces the number single-occupancy trips.
- Reduced GHG emissions. The grams of CO₂ per person kilometer traveled for a car is 243.8 grams, 20 grams for a streetcar, and zero grams for walking and biking.

(Source: <https://sensibletransport.org.au/project/transport-and-climate-change/>)

- Safer streets for all road users, other drivers, bicyclists, pedestrians. A new controlled study from the Department of Safety and the Environment Institute of Transport Economics in Oslo, Norway showed that the more bikes there were, the more drivers saw bikes and were able to coexist safely with riders. The number of accidents between cars and bicycles decreased substantially as the number of people riding bicycles increased.

9.12. Region of Peel Sustainable Transportation Strategy

It is Nextrans' understanding that in February 2018, the Regional Council approved the goal of a 50% modal split by 2041. The Sustainable Transportation Strategy Report (February 2018) provides the following framework for the Region to meet its goals by:

- increase the current 37% share of trips by walking, cycling, transit, carpooling and telework in Peel Region, to achieve a 50% sustainable mode share by 2041,
- accommodate growth in a way that prioritizes environmental, societal and economic sustainability, and
- contribute to a Regional transportation system that is safe, convenient, efficient, multi-modal, well-integrated and sustainable.

The Strategy focused on building complete street to provide sidewalks and cycling facilities, expand carpool lot and promote more carpooling, telework and parking management.

It is Nextrans' opinion that parking management is the best measure to support this Strategy given that reduce parking in new development will encourage new residents to consider other sustainable modes of transportation such as walking, cycling and public transit.

9.13. City of Mississauga Official Plan

Based on the City of Mississauga Official Plan Chapter 4 (Vision), "the City will plan for a strong, diversified economy supported by a range of mobility options and a variety of housing and community infrastructure to create distinct, complete communities".

One of the Guiding Principles (Section 4.4) states that "Mississauga will provide a range of mobility options (e.g., walking, cycling, transit, vehicular) for people of all ages and abilities by connecting people with places through coordinated land use, urban design and transportation planning efforts".

Furthermore, Policies 8.1.1 and 8.1.8 state that "Through the creation of a multi-modal transportation system, Mississauga will provide transportation choices that encourage a shift in lifestyle toward more sustainable transportation modes, such as transit and active transportation" and "To better utilize existing infrastructure, Mississauga will encourage the application of transportation demand management (TDM) techniques, such as car-pooling, alternative work arrangements and shared parking". It is Nextrans' opinion that TDM techniques such as parking management is one of the best and most effective TDM measures that could help the City achieves those visions and policies.

9.14. City of Mississauga Cycling Master Plan Update

It is Nextrans' understanding that the City of Mississauga has recently completed the Cycling Master Plan Update the final document has been approved by Mississauga City Council. The Cycling Master Plan Update includes recommendations for the City's cycling network which includes 897 kilometres of infrastructure to be built over 27 years. The updated Cycling Master Plan focuses on a few key areas:

- Cycling infrastructure planning and design best practices have changed significantly and updates are required to achieve best practices
- The cycling network must be safe, connected, convenient and comfortable for residents, and visitors of all ages and riding ability to try cycling Implementation of new cycling infrastructure will be coordinated with road rehabilitation and major road construction projects, where possible
- Cycle tracks where a bicycle lane is physically separated from the road by a curb and is either at sidewalk level or slightly lower, reserved for bicycles only
- Bicycle lanes separated from traffic lanes by flexible posts, planters, parking stalls, curbs or other barriers, reserved for bicycles only
- Bicycle lanes where cyclists travel in a lane beside regular traffic lanes, reserved for bicycles only
- Multi-use trails along boulevards and also through parks
- Shared routes between cyclists and motorists on roads with lower speeds

As the proposed development provides a significant amount of bicycle parking spaces to support the City's Cycling initiatives, it is Nextrans' opinion that the proposed development vehicle parking supply should be reduced to support cycling initiatives, otherwise residents will continue to own private vehicles and drive single-occupant-vehicles.

9.15. Conclusion on Why Vehicle Parking Rate Reduction is Justified

Based on the comprehensive justifications provided above, it is concluded that reduction to the residential parking rate is justified, desirable and would support the City of Mississauga Official Plan Policies:

- The proposed parking rate reductions would be consistent with the PPS, the Growth Plan, the Region’s comments on this specific development proposal and the approaches followed by many municipalities in the GTA. In particular, the experience in these other cited municipalities demonstrates that automobile parking minimums can be eliminated and still achieve Official Plan policies which require adequate or sufficient parking off-street or on-site.
- Given these considerations, and in the context of the future Hurontario LRT and GO Expansion Program, as well as the newly available controlled study that definitively ties minimum parking standards to increased automobile usage, the proposed reduction to the minimum automobile parking requirements is justified, desirable and would better support the Official Plan’s vision to:
 - create compact complete communities
 - encourage transportation alternatives to automobiles
 - be consistent with policies aimed at reducing auto-dependence
 - support and encourage land- and cost-efficient forms
 - provide for efficient use of land next to planned transit

10.0 BICYCLE PARKING ASSESSMENT

Table 12 summarizes the City of Mississauga Zoning By-law bicycle parking requirement (Table 3.1.6.5.1) for the proposed development to support TDM and active transportation.

Table 12 – Bicycle Parking Space Requirements

Land Use	No. of Unit / GFA	Class B - Short Term		Class A - Long Term		Total
		Rates	Spaces	Rates	Spaces	
Residential	232 units	0.05 spaces/unit	12	0.60 spaces/unit	140	152
Non-residential	556.4 m ²	0.15 spaces/100 m ²	6	0.20 spaces/100 m ²	1	7
Total			18		141	159

Based on the assessment above, the proposed development is required and will provide a minimum of 159 bicycle parking spaces, including 18 Class B spaces (short-term spaces for visitors and non-resident) and 141 Class A spaces (long-term spaces for resident).

Nextrans also recommends that the proposed development provides one bicycle repair station on-site, at convenient location where residents can easily have access to.

The analysis indicates that the proposed bicycle parking supply by the proposed development will support the vehicle parking reduction as this will encourage residents to take active mode of transportation to work, school and discretionary trips instead of driving private vehicles.

11.0 TRANSPORTATION DEMAND MANAGEMENT

Transportation Demand Management (TDM) is a co-ordinated series of actions aimed at maximizing the people moving capability of the transportation system. Intended to reduce single-occupant auto use, potential TDM measures include: TDM supportive land use, bicycle and pedestrian programs and facilities, public transit improvements, preferential treatments for buses and ridesharing, where appropriate.

The following TDM incentives are recommended for the proposed residential development, based on Nextrans’ review of the City of Mississauga Cycling Master Plan, Moving Mississauga Report and the Region of Peel TDM Strategy:

- Provide direct shared pedestrian/bicycle connections from the proposed development to Queen Street S and James Street, as illustrated in **Figure 12**;

- Provide one bicycle repair station on-site, at convenient location where residents can easily have access to;
- Provide a minimum of 159 bicycle parking spaces, including 18 Class B spaces (short-term spaces for visitors and non-resident) and 141 Class A spaces (long-term spaces for resident).
- Provide information package for new residents. The information package includes Mississauga MiWay bus route schedules and community and cycling maps, as well as GO Transit schedules. The Information Package can be distributed at the sale office; and
- Provide pre-load PRESTO Cards with the starting value of \$50 (inclusive of the registration fee) to the residents on demand basis. This will help the future residents to consider taking Mississauga MiWay Transit as an alternative mode of transportation. The pre-loaded PRESTO Cards can be distributed in conjunction with the Information Package at the time of purchase or at occupancy.

12.0 CONCLUSIONS / FINDINGS

12.1. Study Conclusions

The findings and conclusions of the analysis are as follows:

- The proposed development is expected to generate:
 - 90 total two-way auto trips (21 inbound and 69 outbound) and 91 total two-way auto trips (56 inbound and 35 outbound) during the AM and PM peak hours, respectively; and
 - 35 total two-way transit trips (8 inbound and 27 outbound) and 22 total two-way transit trips (13 inbound and 9 outbound) during the AM and PM peak hours, respectively
- The intersection capacity analysis indicates that under the existing, future background and future total traffic conditions, all intersections are expected to operate at acceptable levels of service. There are several critical movements at the Britannia Road W/Queen Street S intersection such as the and eastbound left turn during the morning peak hour and northbound left turn during the afternoon peak hour. These are results of existing and future background traffic on Britannia Road W and Queen Street S.

The potential mitigation measures for these movements would be optimizing the existing signal timing plan to allocate additional green time for these two movements and balance other movements. Although this measure may not address all of the critical movements, however, this measure is less disruptive and more cost effective than intersection widening. It should be noted that intersection widening will impact pedestrian distance crossing and will increase usage of private vehicles. The other measures may also include, but not limited to vehicle parking reduction and appropriate TDM measures for all background developments in the area, and future improvements of the active transportation network in the area.

- The analysis indicates that the proposed development has negligible impacts to the roadway intersections.
- The analysis indicates that the transit passenger demands generated by the proposed development can be accommodated by the existing and future transit services in the area. Therefore, no improvements to the transit system are required to accommodate the proposed development.
- Based on the applicable Zoning By-law, the proposed development would be required to provide a total of 255 vehicle parking spaces, inclusive of residential, visitor and retail uses. Nextrans has provided a comprehensive justification in this Study and recommended appropriate rates for the proposed development. Based on the recommended vehicle parking rates, the proposed development will provide a total of 239 vehicle parking spaces for both resident, visitor and non-residential components. This includes 193 residential vehicle parking spaces and 46 visitor/non-residential shared vehicle parking spaces.

- Based on the City's Zoning By-law, the proposed development is required and will provide a minimum of 159 bicycle parking spaces, including 18 Class B spaces (short-term spaces for visitors and non-resident) and 141 Class A spaces (long-term spaces for resident). Nextrans also recommends that the proposed development provides one bicycle repair station on-site, at convenient location where residents can easily have access to. The analysis indicates that the proposed bicycle parking supply by the proposed development will support the vehicle parking reduction as this will encourage residents to take active mode of transportation to work, school and discretionary trips instead of driving private vehicles.
- The proposed development provides one loading space on-site based on the Zoning By-law requirement. AutoTURN software was used (Garbage truck TAC-HSU and passenger vehicle) to generate vehicular turning templates to confirm and demonstrate the accessibility for the proposed on-site loading space.

12.2. Study Recommendations

Based on the Study assessment, the following recommendations are provided:

- The proposed development implements the TDM measures recommended in this Study;
- The proposed development provides the sidewalk network as illustrated in **Figure 12**;
- Provide one bicycle repair station on-site, at a convenient location;
- The proposed development access configuration includes: one inbound and one outbound (3.5 m width for each lane) and a shared westbound through/right and an eastbound shared through/left on James Street. No exclusive turning lanes are required at the proposed site access;
- The Region/City considers optimize the existing signal timing plan for the Queen Street South/Britannia Road W intersection to improve some critical movements, where appropriate; and
- No additional physical improvements for the area road network and intersections to accommodate the proposed improvements

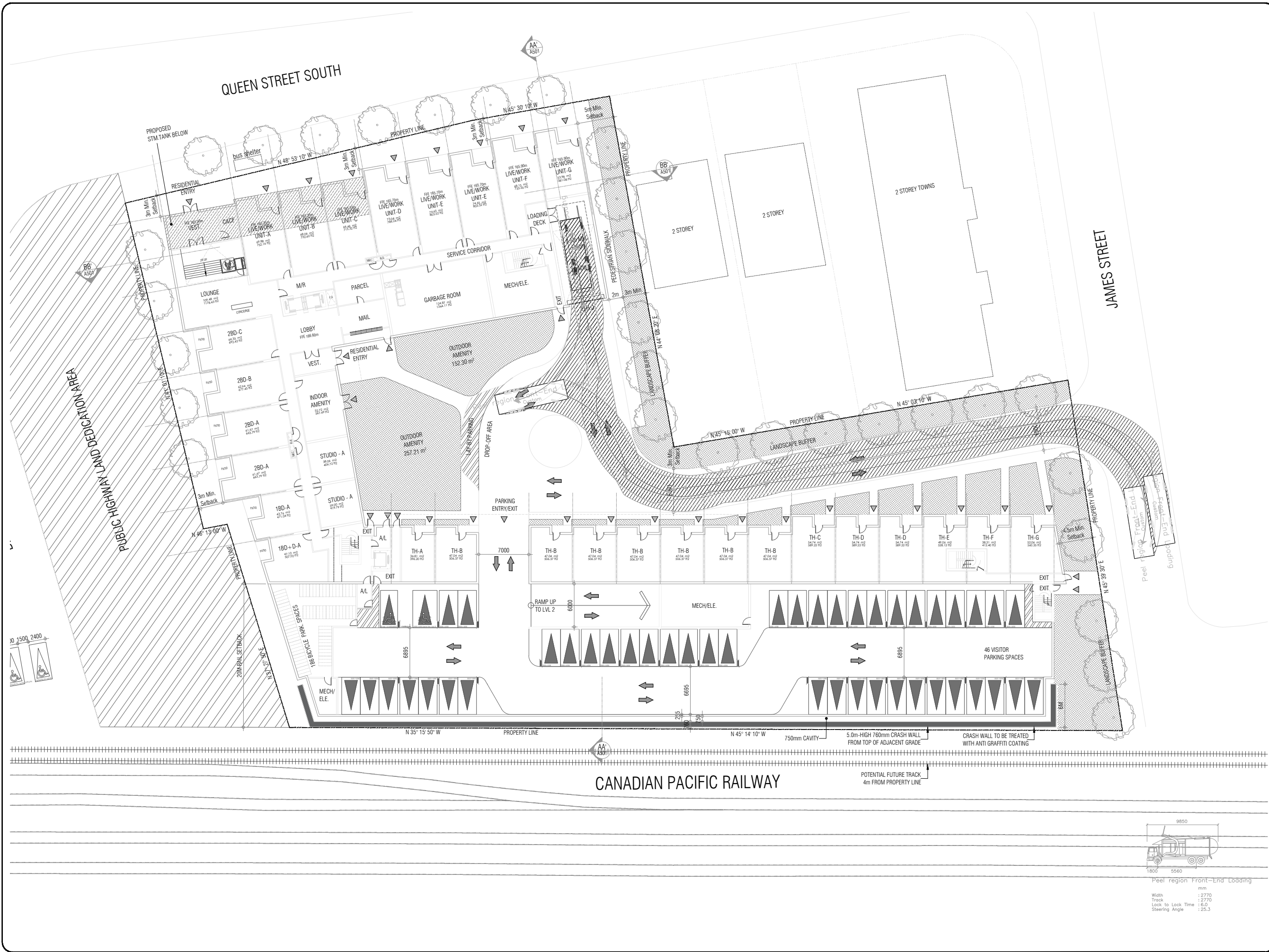

KEY PLAN

BENCHMARK

REVISIONS

NO	REVISION	DATE	BY

STAMP



PROJECT NAME:
Residential Development
William Street
(City of Mississauga)

DRAWING TITLE:
AutoTURN Analysis
(Peel Region
Front Loader)

DESIGN BY: K.A.	DATE: January 9, 2023
CHECKED BY: R.P.	PROJECT NO. NT-20-212
DRAWN BY: K.A.	DRAWING NO. Figure 15
SCALE: NTS	

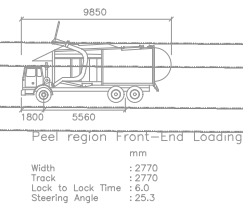

Peel region Front-End Loading
mm
Width : 2770
Track : 2770
Lock to Lock Time : 16.0
Steering Angle : 25.3

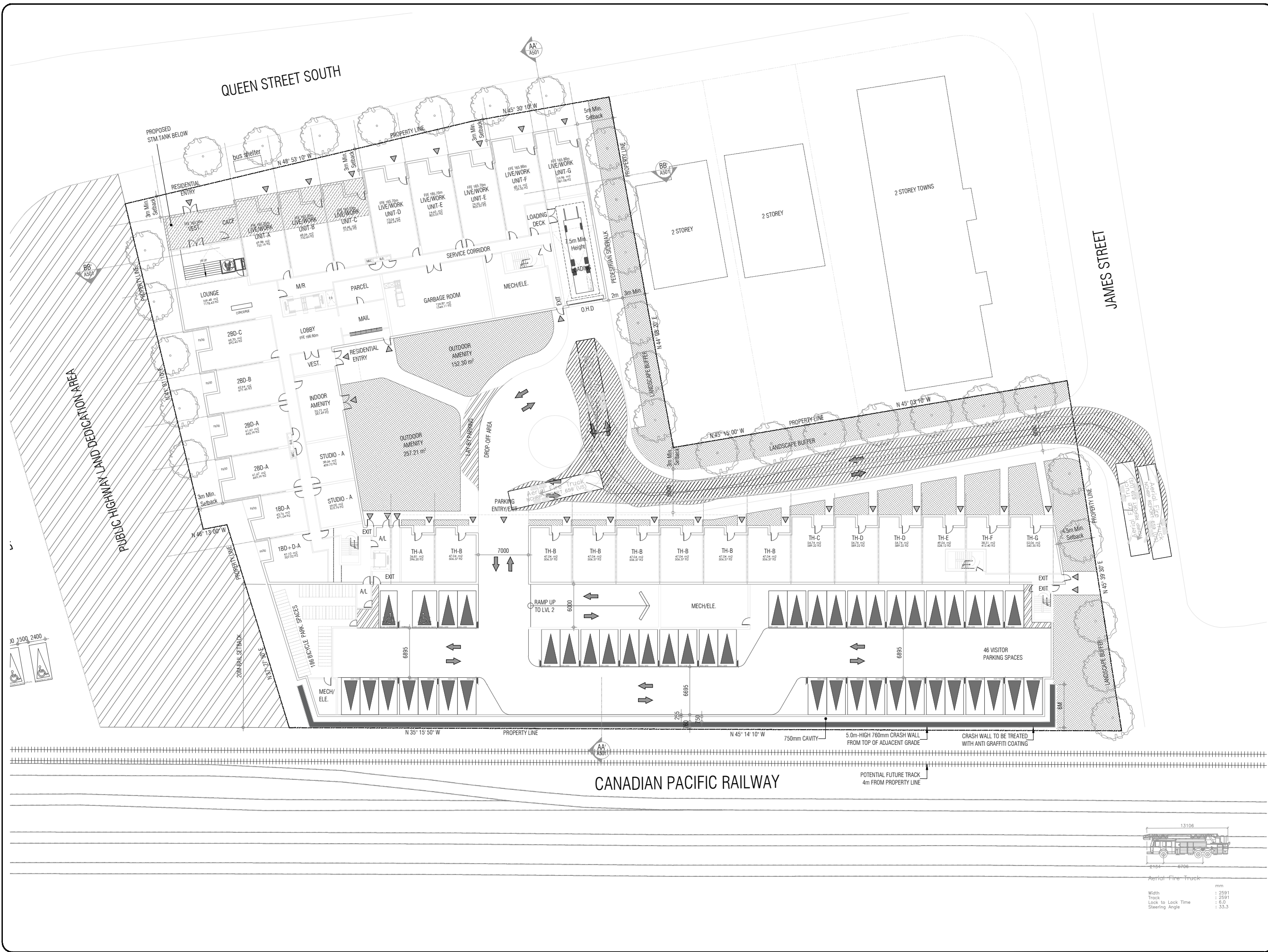

KEY PLAN

BENCHMARK

REVISIONS

NO	REVISION	DATE	BY

STAMP



PROJECT NAME:
Residential Development
William Street
(City of Mississauga)

DRAWING TITLE:
AutoTURN Analysis
(Aerial Fire Truck
(NCHRP Report 659 US))

DESIGN BY: K.A.	DATE: January 9, 2023
CHECKED BY: R.P.	PROJECT NO. NT-20-212
DRAWN BY: K.A.	DRAWING NO. Figure 176
SCALE: NTS	

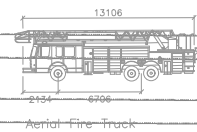

Aerial Fire Truck
mm
Width : 2591
Track : 2591
Lock to Lock Time : 6.0
Steering Angle : 33.3

Appendix A

**Existing Traffic Data, Signal Timing Plans
and Terms of Reference**

From: Tyler Xuereb <Tyler.Xuereb@mississauga.ca>

Sent: Thursday, March 4, 2021 10:32 AM

To: Sam Nguyen <sam@nexttrans.ca>

Subject: RE: Term of Reference for 8, 10 and 12 Queen Street S, Mississauga (City File: DARC 20/196 W11 - 6-12 Queen Street South)

Good Morning Sam,

Using the City's Travel Demand Model and supporting traffic count data, the City's Transportation Planning section has determined the projected growth on Queen Street to be used as part of your study. The recommended projected growth is shown below:

Queen Street

	Compounded Annual Growth from Existing to 2028	
	NB	SB
AM Peak Hour	0.0%	1.0%
PM Peak Hour	0.5%	0.5%

Regards,



Tyler Xuereb

Transportation Planning Analyst

T 905-615-3200 ext.4783

Tyler.xuereb@mississauga.ca

[City of Mississauga](#) | Transportation and Works Department,
Infrastructure Planning and Engineering Services Division

Please consider the environment before printing.

From: Sam Nguyen <sam@nextrans.ca>
Sent: Tuesday, March 2, 2021 10:01 AM
To: Tyler Xuereb <Tyler.Xuereb@mississauga.ca>
Subject: FW: Term of Reference for 8, 10 and 12 Queen Street S, Mississauga (City File: DARC 20/196 W11 - 6-12 Queen Street South)

Hi Tyler,

I also need the growth rate for James Street and Queen Street South and Britannia Road West

Thanks,

Sam (Trang) Nguyen
Transportation Analyst

o: 905-503-2563 ext. 207
e: sam@nextrans.ca
w: www.nextrans.ca

NexTrans Consulting Engineers
A Division of NextEng Consulting Group Inc.
520 Industrial Parkway South, Suite 201
Aurora ON L4G 6W8

From: Kate Vassilyev <Kate.Vassilyev@mississauga.ca>
Sent: Friday, February 26, 2021 2:34 PM
To: Sam Nguyen <sam@nextrans.ca>
Cc: Ryan Au <Ryan.Au@mississauga.ca>
Subject: RE: Term of Reference for 8, 10 and 12 Queen Street S, Mississauga (City File: DARC 20/196 W11 - 6-12 Queen Street South)

Hi Sam,

Thank you for providing the Terms of Reference for 8,10,12 Queen Street S. Staff have reviewed it and provided the following comments in blue:

1. Study Area intersection (depending on available counts, given the COVID-19 situation). We would like to use the available City counts as much as possible for the following intersection:
 - o William Street and James Street (not required)
1. Background Developments and Growth Rate
 - a. Obtain growth rate from the City. Please confirm and validate growth rates and historical counts with Tyler Xuereb (tyler.xuereb@mississauga.ca) from Transportation Planning Section.
 - b. Only one active background development applications in Ward 6 that are close to the proposed development: The following development should be included:
 - i. OZ 20-4 W11 - 1240 Britannia Road W
 - j. OZ 17-20 W11 – 36, 38, 40, 44, 46 Main Street
 - k. OZ 19-11 W11 – 64/66 Thomas St
 - l. T 20-4 W 11 - 51 & 57 Tannery Street and 208 Emby Drive
 - m. T 11-006 & OZ 16-11 W11 – 5155 Mississauga Rd
 - n. OZ 20-11 W11 – 86 Thomas Street

- o. CDM 20-7 W11 – 80 Thomas Street
- p. SP 20-114 W11 – 66 Queen St S

- 2. Future Total Assessment. The following tasks will be conducted for the future total conditions: Please include all applicable Synchro reports in the Appendix.

Please let me know if you have any questions.
Regards,



Kate (Jekaterina) Vassilyev

Traffic Planning Technologist
T 905-615-3200 ext.8171
kate.vassilyev@mississauga.ca

[City of Mississauga](#) | Corporate Services Department,
Business Services Division

Please consider the environment before printing.

From: Sam Nguyen [<mailto:sam@nexttrans.ca>]
Sent: Friday, February 19, 2021 9:28 AM
To: Ryan Au <Ryan.Au@mississauga.ca>
Subject: Term of Reference for 8, 10 and 12 Queen Street S, Mississauga

Hi Ryan

We are currently working on a TIS to support the proposed development located at 8, 10 and 12 Queen Street S, in the City of Mississauga. The proposed scope of the TIS is as follows. If possible, please provide us with your comments at your earliest convenient.

- 1. Study Area intersection (depending on available counts, given the COVID-19 situation). We would like to use the available City counts as much as possible for the following intersection:
 - a. James Street and Queen Street South
 - b. Queen Street South and Britannia Road West, and,
 - c. Site Accesses
- 2. Horizon Year
 - a. Project completion by 2023
 - b. Analysis horizon year 2028 (5 year horizon)
- 2. Background Developments and Growth Rate
 - a. Obtain growth rate from the City
 - b. Only one active background development applications in Ward 6 that are close to the proposed development:
 - i. 1240 Britannia Road W
- 4. Trip Generation
 - a. ITE Trip Generation Manual 10th Edition
 - b. Multimodal trip generation using 2016 TTS modal split data
- 5. Trip Distribution

- a. Extract 2016 TTS data based on the surrounding traffic zones where appropriate
5. Future Total Assessment
 - The following tasks will be conducted for the future total conditions:
 - Future Total Traffic Assessment for Auto Mode
 - Future Transit Mode Assessment
 - Future Active Transportation Mode Assessment
 - Proposed Access and Operation/Safety Assessment
 - Loading Requirement and Assessment
 - Vehicular and Bicycle Parking Assessment
 - Internal Site Circulation (if necessary)
 - On-Site Circulation & Garbage Loading
 7. Transit, Active Transportation and TDM
 - a. Conduct a review of the existing and proposed future transit network in the area. Based on these findings, appropriate recommendations will be provided to ensure adequate walking distances to/from the proposed development to transit stations/stops.
 - b. Review the existing and proposed future active transportation network in the area. Based on these findings, Nextrans will identify missing gaps and additional interconnections and connections from the proposed development to adjacent land uses, the City and the Region's facilities, as well as to transition stations/stops.
 - c. A Transportation Demand Management (TDM) assessment will be undertaken to identify specific measures and programs to reduce single-occupant-vehicle trips to/from the proposed development. These TDM measures and programs may include but not limited to, Carpooling, Auto Share, Bike racks, Parking management strategies, etc. The TDM report will be completed and included as part of this Study for submission purposes submitted in accordance with the City and the Region requirements.
 8. Parking Justification Study

Sam (Trang) Nguyen
Transportation Analyst

o: 905-503-2563 ext. 207
e: sam@nextrans.ca
w: www.nextrans.ca

NexTrans Consulting Engineers
A Division of NextEng Consulting Group Inc.
520 Industrial Parkway South, Suite 201
Aurora ON L4G 6W8

Date: March 11, 2021
From: Sam Nguyen, NexTrans Consulting Engineers
Re: Growth Rates Data Request – Britannia Road at Queen Street

Sam,
Here are the estimated CAGR values for Britannia Road at Queen Street:

2016 – 2021	2021 – 2031
0.5%	0.5%

These growth rates are estimated based on multiple sources including Peel Travel Demand forecasting model, ATR and land use/forecasts data. Please note that this area may be further affected by future growth (after 2031 and beyond). Please use your professional judgement when using these values.

If you require further assistance, please contact me at (905) 791-7800 ext. 4810.

Regards,

Tiggy Chen
Co-op Student, Transportation System Planning
Transportation Division, Public Works Services, Region of Peel
10 Peel Centre Drive, Suite B, 4th Floor
Brampton, ON L6T 4B9
W: (905) 791-7800 x4810 C: (647) 918-2827
E: tiggy.chen@peelregion.ca

REGIONAL MUNICIPALITY OF PEEL

Traffic Signal Timing Parameters

Database Date	February 8, 2021		Prepared Date	February 8, 2021
Database Rev	iNET		Completed By	JP
Timing Card / Field rev			Checked By	MA

Location Britannia Road at Queen Street North

Phase #	Street Name - Direction	Vehicle Minimum (s)	Pedestrian Minimum (s)		Amber (s)	All Red (s)	TIME PERIOD (s) (Green+Amber+All Red)		
			WALK	FDWALK			AM SPLITS	OFF SPLITS	PM
			1	Britannia Road - WB PP LT			8	0	0
2	Britannia Road - EB	12	8	20	4	3.1	83	80	74
3	Queen Street N - SB PP LT	8	0	0	3	0	13	13	17
4	Queen Street N - NB	12	9	22	4	3.9	53	54	58
5	Britannia Road - EB PP LT	8	0	0	3	0	13	13	13
6	Britannia Road - WB	12	8	20	4	3.1	81	80	72
7	Queen Street N - NB PP LT	8	0	0	3	0	0	19	14
8	Queen Street N - SB	12	9	22	4	3.9	66	48	61

System Control	TIME (M-F)	PEAK	CYCLE LENGTH (s)	OFFSET (s)
Yes	06:00 - 09:30	AM	160	155
Semi-Actuated Mode	09:30 - 15:00	OFF	160	69
Yes	19:30 - 03:00	PM	160	114



Turning Movement Count (1 . BRITANNIA RD W & QUEEN ST S) CustID: 00305449 MioID:

Start Time	N Approach QUEEN ST						E Approach BRITANNIA RD						S Approach QUEEN ST						W Approach BRITANNIA RD						Int. Total (15 min)	Int. Total (1 hr)	
	Right N:W	Thru N:S	Left N:E	UTurn N:N	Peds N:	Approach Total	Right E:N	Thru E:W	Left E:S	UTurn E:E	Peds E:	Approach Total	Right S:E	Thru S:N	Left S:W	UTurn S:S	Peds S:	Approach Total	Right W:S	Thru W:E	Left W:N	UTurn W:W	Peds W:	Approach Total			
07:00:00	17	26	10	0	2	53	15	87	11	0	1	113	12	30	8	0	1	50	7	163	28	0	1	198	414		
07:15:00	21	30	20	0	1	71	20	116	18	0	2	154	17	33	16	0	2	66	13	173	19	0	0	205	496		
07:30:00	24	19	15	0	4	58	37	130	13	0	8	180	16	46	10	0	1	72	15	271	23	0	3	309	619		
07:45:00	35	35	23	0	0	93	34	150	19	0	6	203	18	60	16	0	1	94	24	301	31	0	1	356	746	2275	
08:00:00	30	47	23	0	0	100	48	152	19	0	2	219	25	60	15	0	3	100	26	355	47	0	0	428	847	2708	
08:15:00	32	46	30	0	0	108	47	179	20	0	1	246	15	94	34	0	2	143	28	290	53	0	0	371	868	3080	
08:30:00	41	70	37	0	6	148	50	158	32	0	4	240	24	81	21	0	1	126	21	323	60	1	6	405	919	3380	
08:45:00	36	68	39	0	4	143	53	186	24	0	0	263	21	98	26	0	0	145	34	358	39	0	4	431	982	3616	
09:00:00	41	59	29	0	1	129	35	149	33	0	1	217	34	75	24	0	1	133	28	254	62	0	2	344	823	3592	
09:15:00	32	50	27	0	4	109	39	145	29	0	1	213	16	54	15	0	1	85	26	194	42	0	4	262	669	3393	
09:30:00	26	49	20	0	0	95	24	123	32	0	1	179	19	45	18	0	2	82	15	162	31	0	0	208	564	3038	
09:45:00	21	35	23	0	1	79	20	126	35	0	1	181	20	29	14	0	1	63	22	158	26	0	0	206	529	2585	
BREAK																											
16:00:00	49	65	56	0	1	170	16	294	26	0	4	336	27	90	47	0	3	164	20	203	27	0	4	250	920		
16:15:00	33	65	45	0	4	143	27	316	25	0	3	368	32	69	36	0	6	137	24	200	32	0	4	256	904		
16:30:00	52	75	43	0	0	170	29	278	41	0	2	348	41	78	41	0	4	160	26	178	29	0	1	233	911		
16:45:00	39	73	39	0	2	151	25	341	25	0	9	391	43	84	42	0	7	169	39	194	28	0	0	261	972	3707	
17:00:00	59	69	47	0	5	175	29	326	34	0	7	389	27	91	34	0	1	152	24	218	27	0	6	269	985	3772	
17:15:00	42	82	64	0	4	188	21	308	29	0	4	358	29	85	49	0	2	163	24	185	25	0	4	234	943	3811	
17:30:00	36	71	47	0	2	154	26	359	25	0	8	410	29	64	43	0	1	136	42	231	37	0	1	310	1010	3910	
17:45:00	40	61	40	0	2	141	28	329	24	0	12	381	33	73	41	0	4	147	29	206	38	0	0	273	942	3880	
18:00:00	30	64	39	0	2	133	24	309	38	0	3	371	25	85	36	0	2	146	28	206	25	0	0	259	909	3804	
18:15:00	34	67	22	0	1	123	20	280	35	0	8	335	40	65	17	0	4	122	38	204	24	0	0	266	846	3707	
18:30:00	32	54	30	0	3	116	20	241	28	0	5	289	31	65	30	0	4	126	30	206	20	0	3	256	787	3484	
18:45:00	31	59	32	0	2	122	32	241	31	0	4	304	54	76	30	0	1	160	25	186	24	0	6	235	821	3363	
Grand Total	833	1339	800	0	51	2972	719	5323	646	0	97	6688	648	1630	663	0	55	2941	608	5419	797	1	50	6825	19426	-	
Approach%	28%	45.1%	26.9%	0%	-	-	10.8%	79.6%	9.7%	0%	-	-	22%	55.4%	22.5%	0%	-	8.9%	79.4%	11.7%	0%	-	-	-	-		
Totals %	4.3%	6.9%	4.1%	0%	-	15.3%	3.7%	27.4%	3.3%	0%	-	34.4%	3.3%	8.4%	3.4%	0%	-	15.1%	3.1%	27.9%	4.1%	0%	-	35.1%	-		
Heavy	33	31	23	0	-	-	31	197	17	0	-	-	13	44	25	0	-	9	170	22	0	-	-	-	-		
Heavy %	4%	2.3%	2.9%	0%	-	-	4.3%	3.7%	2.6%	0%	-	-	2%	2.7%	3.8%	0%	-	1.5%	3.1%	2.8%	0%	-	-	-	-		
Bicycles	-	-	-	-	-	-	-	-	-	-	-	-	-	-	-	-	-	-	-	-	-	-	-	-	-	-	
Bicycle %	-	-	-	-	-	-	-	-	-	-	-	-	-	-	-	-	-	-	-	-	-	-	-	-	-	-	



Peak Hour: 08:00 AM - 09:00 AM Weather: Light Rain (16.77 °C)

Start Time	N Approach QUEEN ST						E Approach BRITANNIA RD						S Approach QUEEN ST						W Approach BRITANNIA RD						Int. Total (15 min)		
	Right	Thru	Left	UTurn	Peds	Approach Total	Right	Thru	Left	UTurn	Peds	Approach Total	Right	Thru	Left	UTurn	Peds	Approach Total	Right	Thru	Left	UTurn	Peds	Approach Total			
08:00:00	30	47	23	0	0	100	48	152	19	0	2	219	25	60	15	0	3	100	26	355	47	0	0	428	847		
08:15:00	32	46	30	0	0	108	47	179	20	0	1	246	15	94	34	0	2	143	28	290	53	0	0	371	868		
08:30:00	41	70	37	0	6	148	50	158	32	0	4	240	24	81	21	0	1	126	21	323	60	1	6	405	919		
08:45:00	36	68	39	0	4	143	53	186	24	0	0	263	21	98	26	0	0	145	34	358	39	0	4	431	982		
Grand Total	139	231	129	0	10	499	198	675	95	0	7	968	85	333	96	0	6	514	109	1326	199	1	10	1635	3616		
Approach%	27.9%	46.3%	25.9%	0%	-	-	20.5%	69.7%	9.8%	0%	-	-	16.5%	64.8%	18.7%	0%	-	-	6.7%	81.1%	12.2%	0.1%	-	-	-		
Totals %	3.8%	6.4%	3.6%	0%	13.8%	13.8%	5.5%	18.7%	2.6%	0%	26.8%	26.8%	2.4%	9.2%	2.7%	0%	14.2%	14.2%	3%	36.7%	5.5%	0%	45.2%	45.2%	-		
PHF	0.85	0.83	0.83	0	0.84	0.84	0.93	0.91	0.74	0	0.92	0.92	0.85	0.85	0.71	0	0.89	0.89	0.8	0.93	0.83	0.25	0.95	0.95	-		
Heavy	6	9	9	0	24	24	11	47	4	0	62	62	5	3	11	0	19	19	5	48	6	0	59	59	-		
Heavy %	4.3%	3.9%	7%	0%	4.8%	4.8%	5.6%	7%	4.2%	0%	6.4%	6.4%	5.9%	0.9%	11.5%	0%	3.7%	3.7%	4.6%	3.6%	3%	0%	3.6%	3.6%	-		
Lights	133	222	120	0	475	475	187	628	91	0	906	906	80	330	85	0	495	495	104	1278	193	1	1576	1576	-		
Lights %	95.7%	96.1%	93%	0%	95.2%	95.2%	94.4%	93%	95.8%	0%	93.6%	93.6%	94.1%	99.1%	88.5%	0%	96.3%	96.3%	95.4%	96.4%	97%	100%	96.4%	96.4%	-		
Single-Unit Trucks	1	3	7	0	11	11	6	13	2	0	21	21	2	0	2	0	4	4	1	11	2	0	14	14	-		
Single-Unit Trucks %	0.7%	1.3%	5.4%	0%	2.2%	2.2%	3%	1.9%	2.1%	0%	2.2%	2.2%	2.4%	0%	2.1%	0%	0.8%	0.8%	0.9%	0.8%	1%	0%	0.9%	0.9%	-		
Buses	5	5	1	0	11	11	4	32	2	0	38	38	2	3	9	0	14	14	2	32	4	0	38	38	-		
Buses %	3.6%	2.2%	0.8%	0%	2.2%	2.2%	2%	4.7%	2.1%	0%	3.9%	3.9%	2.4%	0.9%	9.4%	0%	2.7%	2.7%	1.8%	2.4%	2%	0%	2.3%	2.3%	-		
Articulated Trucks	0	1	1	0	2	2	1	2	0	0	3	3	1	0	0	0	1	1	2	5	0	0	7	7	-		
Articulated Trucks %	0%	0.4%	0.8%	0%	0.4%	0.4%	0.5%	0.3%	0%	0%	0.3%	0.3%	1.2%	0%	0%	0%	0.2%	0.2%	1.8%	0.4%	0%	0%	0.4%	0.4%	-		
Bicycles on Road	0	0	0	0	0	0	0	0	0	0	0	0	0	0	0	0	0	0	0	0	0	0	0	0	0	-	
Bicycles on Road %	0%	0%	0%	0%	0%	0%	0%	0%	0%	0%	0%	0%	0%	0%	0%	0%	0%	0%	0%	0%	0%	0%	0%	0%	0%	-	
Pedestrians	-	-	-	-	10	10	-	-	-	-	7	7	-	-	-	-	6	6	-	-	-	-	10	10	10	-	
Pedestrians %	-	-	-	-	30.3%	30.3%	-	-	-	-	21.2%	21.2%	-	-	-	-	18.2%	18.2%	-	-	-	-	30.3%	30.3%	30.3%	-	
Bicycles on Crosswalk	-	-	-	-	0	0	-	-	-	-	0	0	-	-	-	-	0	0	-	-	-	-	0	0	0	-	
Bicycles on Crosswalk %	-	-	-	-	0%	0%	-	-	-	-	0%	0%	-	-	-	-	0%	0%	-	-	-	-	0%	0%	0%	0%	-



Peak Hour: 04:45 PM - 05:45 PM Weather: Light Intensity Shower Rain (19.06 °C)

Start Time	N Approach QUEEN ST						E Approach BRITANNIA RD						S Approach QUEEN ST						W Approach BRITANNIA RD						Int. Total (15 min)
	Right	Thru	Left	UTurn	Peds	Approach Total	Right	Thru	Left	UTurn	Peds	Approach Total	Right	Thru	Left	UTurn	Peds	Approach Total	Right	Thru	Left	UTurn	Peds	Approach Total	
16:45:00	39	73	39	0	2	151	25	341	25	0	9	391	43	84	42	0	7	169	39	194	28	0	0	261	972
17:00:00	59	69	47	0	5	175	29	326	34	0	7	389	27	91	34	0	1	152	24	218	27	0	6	269	985
17:15:00	42	82	64	0	4	188	21	308	29	0	4	358	29	85	49	0	2	163	24	185	25	0	4	234	943
17:30:00	36	71	47	0	2	154	26	359	25	0	8	410	29	64	43	0	1	136	42	231	37	0	1	310	1010
Grand Total	176	295	197	0	13	668	101	1334	113	0	28	1548	128	324	168	0	11	620	129	828	117	0	11	1074	3910
Approach%	26.3%	44.2%	29.5%	0%	-	-	6.5%	86.2%	7.3%	0%	-	-	20.6%	52.3%	27.1%	0%	-	-	12%	77.1%	10.9%	0%	-	-	-
Totals %	4.5%	7.5%	5%	0%	17.1%	17.1%	2.6%	34.1%	2.9%	0%	39.6%	39.6%	3.3%	8.3%	4.3%	0%	15.9%	15.9%	3.3%	21.2%	3%	0%	27.5%	27.5%	-
PHF	0.75	0.9	0.77	0	0.89	0.89	0.87	0.93	0.83	0	0.94	0.94	0.74	0.89	0.86	0	0.92	0.92	0.77	0.9	0.79	0	0.87	0.87	-
Heavy	3	4	3	0	10	10	2	22	0	0	24	24	2	5	3	0	10	10	0	26	3	0	29	29	-
Heavy %	1.7%	1.4%	1.5%	0%	1.5%	1.5%	2%	1.6%	0%	0%	1.6%	1.6%	1.5%	1.8%	0%	0%	1.6%	1.6%	0%	3.1%	2.6%	0%	2.7%	2.7%	-
Lights	173	291	194	0	658	658	99	1312	113	0	1524	1524	126	317	165	0	608	608	128	802	114	0	1044	1044	-
Lights %	98.3%	98.6%	98.5%	0%	98.5%	98.5%	98%	98.4%	100%	0%	98.4%	98.4%	98.4%	97.8%	98.2%	0%	98.1%	98.1%	99.2%	96.9%	97.4%	0%	97.2%	97.2%	-
Single-Unit Trucks	1	1	0	0	2	2	2	11	0	0	13	13	1	1	0	0	2	2	0	8	0	0	8	8	-
Single-Unit Trucks %	0.6%	0.3%	0%	0%	0.3%	0.3%	2%	0.8%	0%	0%	0.8%	0.8%	0.8%	0.3%	0%	0%	0.3%	0.3%	0%	1%	0%	0%	0.7%	0.7%	-
Buses	2	3	1	0	6	6	0	8	0	0	8	8	0	3	3	0	6	6	0	11	2	0	13	13	-
Buses %	1.1%	1%	0.5%	0%	0.9%	0.9%	0%	0.6%	0%	0%	0.5%	0.5%	0%	0.9%	1.8%	0%	1%	1%	0%	1.3%	1.7%	0%	1.2%	1.2%	-
Articulated Trucks	0	0	2	0	2	2	0	3	0	0	3	3	1	1	0	0	2	2	0	7	1	0	8	8	-
Articulated Trucks %	0%	0%	1%	0%	0.3%	0.3%	0%	0.2%	0%	0%	0.2%	0.2%	0.8%	0.3%	0%	0%	0.3%	0.3%	0%	0.8%	0.9%	0%	0.7%	0.7%	-
Bicycles on Road	0	0	0	0	0	0	0	0	0	0	0	0	0	2	0	0	2	2	1	0	0	0	1	1	-
Bicycles on Road %	0%	0%	0%	0%	0%	0%	0%	0%	0%	0%	0%	0%	0%	0.6%	0%	0%	0.3%	0.3%	0.8%	0%	0%	0%	0.1%	0.1%	-
Pedestrians	-	-	-	-	11	11	-	-	-	-	23	23	-	-	-	-	7	7	-	-	-	-	11	11	-
Pedestrians %	-	-	-	-	17.5%	17.5%	-	-	-	-	36.5%	36.5%	-	-	-	-	11.1%	11.1%	-	-	-	-	17.5%	17.5%	-
Bicycles on Crosswalk	-	-	-	-	2	2	-	-	-	-	5	5	-	-	-	-	4	4	-	-	-	-	0	0	-
Bicycles on Crosswalk %	-	-	-	-	3.2%	3.2%	-	-	-	-	7.9%	7.9%	-	-	-	-	6.3%	6.3%	-	-	-	-	0%	0%	-

Peak Hour: 08:00 AM - 09:00 AM Weather: Light Rain (16.77 °C)



Peak Hour: 04:45 PM - 05:45 PM Weather: Light Intensity Shower Rain (19.06 °C)





Turning Movement Count (4 . JAMES ST & WILLIAM ST)

Start Time	N Approach WILLIAM ST					E Approach JAMES ST					S Approach WILLIAM ST					Int. Total (15 min)	Int. Total (1 hr)
	Thru N:S	Left N:E	UTurn N:N	Peds N:	Approach Total	Right E:N	Left E:S	UTurn E:E	Peds E:	Approach Total	Right S:E	Thru S:N	UTurn S:S	Peds S:	Approach Total		
07:00:00	0	0	0	0	0	0	1	0	0	1	0	0	0	0	0	1	
07:15:00	0	0	0	0	0	0	2	0	0	2	0	0	0	0	0	2	
07:30:00	0	0	0	0	0	0	0	1	0	1	1	0	0	0	1	2	
07:45:00	0	0	0	0	0	0	2	0	0	2	0	0	0	0	0	2	7
08:00:00	0	0	0	0	0	0	2	0	0	2	0	0	0	0	0	2	8
08:15:00	0	0	0	0	0	0	0	0	0	0	1	0	0	0	1	1	7
08:30:00	0	0	0	0	0	0	2	0	0	2	0	0	0	0	0	2	7
08:45:00	0	0	0	0	0	0	3	0	0	3	3	0	0	0	3	6	11
09:00:00	0	0	0	0	0	0	4	0	1	4	0	0	0	0	0	4	13
09:15:00	0	0	0	0	0	0	2	2	0	4	0	0	0	0	0	4	16
09:30:00	0	0	0	0	0	0	3	0	0	3	3	0	0	0	3	6	20
09:45:00	0	0	0	0	0	0	1	0	0	1	1	0	0	0	1	2	16
BREAK																	
16:00:00	0	0	0	0	0	0	0	0	0	0	0	0	0	0	0	0	
16:15:00	0	0	0	0	0	0	2	0	0	2	3	0	0	0	3	5	
16:30:00	0	0	0	0	0	0	1	0	0	1	0	0	0	0	0	1	
16:45:00	0	0	0	0	0	0	3	0	0	3	1	0	0	0	1	4	10
17:00:00	0	0	0	0	0	0	2	0	0	2	1	0	0	0	1	3	13
17:15:00	0	0	0	0	0	0	1	0	3	1	6	0	0	0	6	7	15
17:30:00	1	0	0	0	1	0	1	0	3	1	1	1	0	0	2	4	18
17:45:00	0	0	0	0	0	0	1	0	1	1	0	0	0	0	0	1	15
18:00:00	0	0	0	0	0	0	1	1	0	2	3	0	0	0	3	5	17
18:15:00	0	0	0	0	0	0	1	0	0	1	0	0	0	0	0	1	11
18:30:00	0	0	0	0	0	0	0	0	0	0	4	0	0	0	4	4	11
18:45:00	0	0	0	0	0	0	0	0	0	0	0	0	0	0	0	0	10
Grand Total	1	0	0	0	1	0	35	4	8	39	28	1	0	0	29	69	-
Approach%	100%	0%	0%	-	-	0%	89.7%	10.3%	-	-	96.6%	3.4%	0%	-	-	-	-
Totals %	1.4%	0%	0%	1.4%	1.4%	0%	50.7%	5.8%	56.5%	56.5%	40.6%	1.4%	0%	42%	42%	-	-
Heavy	0	0	0	-	-	0	5	1	-	-	3	0	0	-	-	-	-
Heavy %	0%	0%	0%	-	-	0%	14.3%	25%	-	-	10.7%	0%	0%	-	-	-	-
Bicycles	-	-	-	-	-	-	-	-	-	-	-	-	-	-	-	-	-
Bicycle %	-	-	-	-	-	-	-	-	-	-	-	-	-	-	-	-	-



Peak Hour: 08:45 AM - 09:45 AM Weather: Light Rain (16.77 °C)

Start Time	N Approach WILLIAM ST					E Approach JAMES ST					S Approach WILLIAM ST					Int. Total (15 min)
	Thru	Left	UTurn	Peds	Approach Total	Right	Left	UTurn	Peds	Approach Total	Right	Thru	UTurn	Peds	Approach Total	
08:45:00	0	0	0	0	0	0	3	0	0	3	3	0	0	0	3	6
09:00:00	0	0	0	0	0	0	4	0	1	4	0	0	0	0	0	4
09:15:00	0	0	0	0	0	0	2	2	0	4	0	0	0	0	0	4
09:30:00	0	0	0	0	0	0	3	0	0	3	3	0	0	0	3	6
Grand Total	0	0	0	0	0	0	12	2	1	14	6	0	0	0	6	20
Approach%	0%	0%	0%		-	0%	85.7%	14.3%		-	100%	0%	0%		-	-
Totals %	0%	0%	0%		0%	0%	60%	10%		70%	30%	0%	0%		30%	-
PHF	0	0	0		0	0	0.75	0.25		0.88	0.5	0	0		0.5	-
Heavy	0	0	0		0	0	2	0		2	2	0	0		2	-
Heavy %	0%	0%	0%		0%	0%	16.7%	0%		14.3%	33.3%	0%	0%		33.3%	-
Lights	0	0	0		0	0	10	2		12	4	0	0		4	-
Lights %	0%	0%	0%		0%	0%	83.3%	100%		85.7%	66.7%	0%	0%		66.7%	-
Single-Unit Trucks	0	0	0		0	0	1	0		1	2	0	0		2	-
Single-Unit Trucks %	0%	0%	0%		0%	0%	8.3%	0%		7.1%	33.3%	0%	0%		33.3%	-
Buses	0	0	0		0	0	1	0		1	0	0	0		0	-
Buses %	0%	0%	0%		0%	0%	8.3%	0%		7.1%	0%	0%	0%		0%	-
Bicycles on Road	0	0	0		0	0	0	0		0	0	0	0		0	-
Bicycles on Road %	0%	0%	0%		0%	0%	0%	0%		0%	0%	0%	0%		0%	-
Pedestrians	-	-	-	0	-	-	-	-	1	-	-	-	-	0	-	-
Pedestrians%	-	-	-	0%	-	-	-	-	100%	-	-	-	-	0%	-	-



Peak Hour: 04:45 PM - 05:45 PM Weather: Light Intensity Shower Rain (19.06 °C)

Start Time	N Approach WILLIAM ST					E Approach JAMES ST					S Approach WILLIAM ST					Int. Total (15 min)
	Thru	Left	UTurn	Peds	Approach Total	Right	Left	UTurn	Peds	Approach Total	Right	Thru	UTurn	Peds	Approach Total	
16:45:00	0	0	0	0	0	0	3	0	0	3	1	0	0	0	1	4
17:00:00	0	0	0	0	0	0	2	0	0	2	1	0	0	0	1	3
17:15:00	0	0	0	0	0	0	1	0	3	1	6	0	0	0	6	7
17:30:00	1	0	0	0	1	0	1	0	3	1	1	1	0	0	2	4
Grand Total	1	0	0	0	1	0	7	0	6	7	9	1	0	0	10	18
Approach%	100%	0%	0%		-	0%	100%	0%		-	90%	10%	0%		-	-
Totals %	5.6%	0%	0%		5.6%	0%	38.9%	0%		38.9%	50%	5.6%	0%		55.6%	-
PHF	0.25	0	0		0.25	0	0.58	0		0.58	0.38	0.25	0		0.42	-
Heavy	0	0	0		0	0	1	0		1	0	0	0		0	-
Heavy %	0%	0%	0%		0%	0%	14.3%	0%		14.3%	0%	0%	0%		0%	-
Lights	1	0	0		1	0	6	0		6	8	1	0		9	-
Lights %	100%	0%	0%		100%	0%	85.7%	0%		85.7%	88.9%	100%	0%		90%	-
Single-Unit Trucks	0	0	0		0	0	1	0		1	0	0	0		0	-
Single-Unit Trucks %	0%	0%	0%		0%	0%	14.3%	0%		14.3%	0%	0%	0%		0%	-
Buses	0	0	0		0	0	0	0		0	0	0	0		0	-
Buses %	0%	0%	0%		0%	0%	0%	0%		0%	0%	0%	0%		0%	-
Bicycles on Road	0	0	0		0	0	0	0		0	1	0	0		1	-
Bicycles on Road %	0%	0%	0%		0%	0%	0%	0%		0%	11.1%	0%	0%		10%	-
Pedestrians	-	-	-	0	-	-	-	-	6	-	-	-	-	0	-	-
Pedestrians%	-	-	-	0%	-	-	-	-	100%	-	-	-	-	0%	-	-

Peak Hour: 08:45 AM - 09:45 AM Weather: Light Rain (16.77 °C)

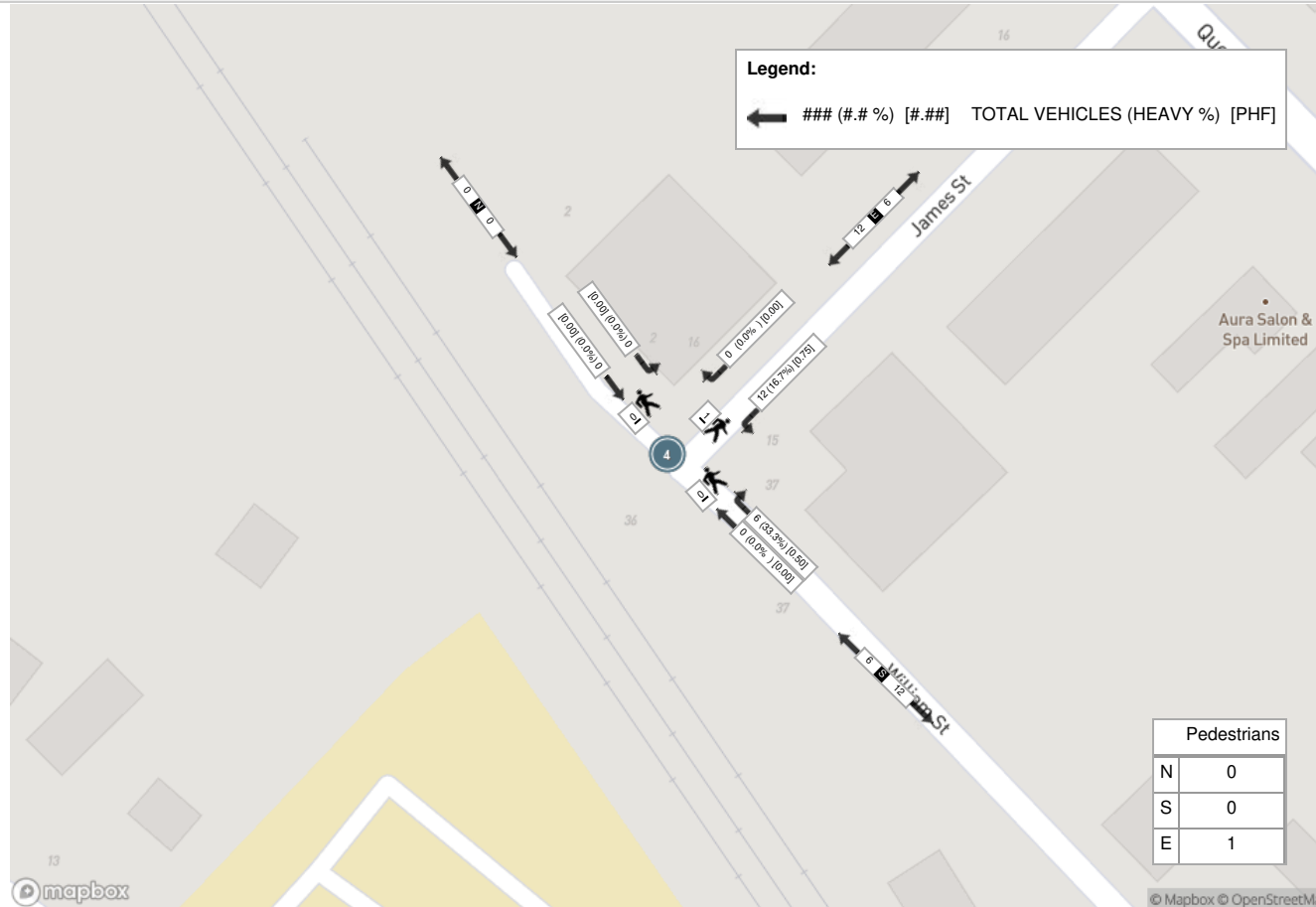

Peak Hour: 04:45 PM - 05:45 PM Weather: Light Intensity Shower Rain (19.06 °C)

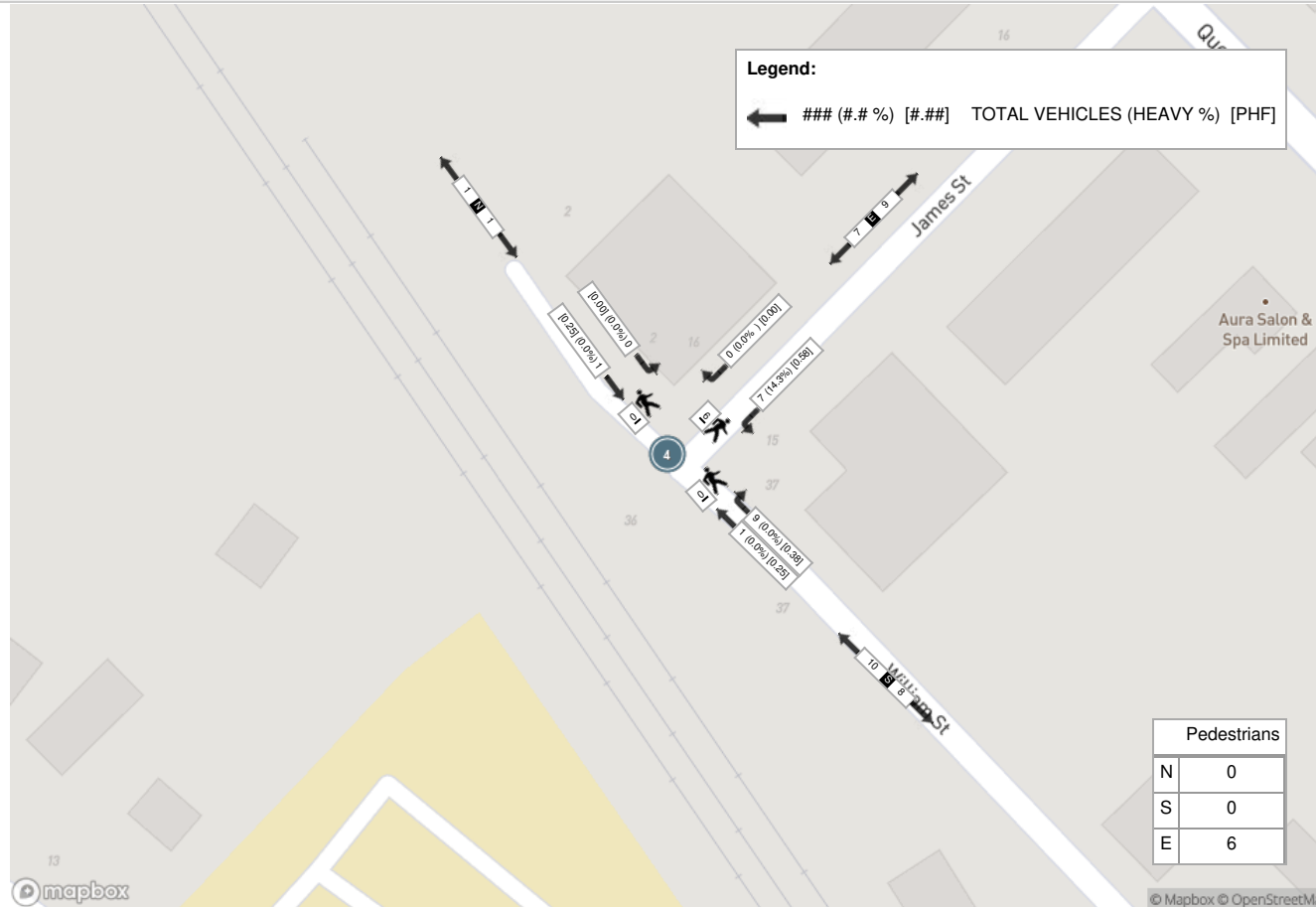



Turning Movement Count (3 . QUEEN ST S & ELLEN ST)

Start Time	N Approach QUEEN ST S					E Approach ELLEN ST					S Approach QUEEN ST S					Int. Total (15 min)	Int. Total (1 hr)
	Thru N:S	Left N:E	UTurn N:N	Peds N:	Approach Total	Right E:N	Left E:S	UTurn E:E	Peds E:	Approach Total	Right S:E	Thru S:N	UTurn S:S	Peds S:	Approach Total		
07:00:00	43	0	0	0	43	1	2	0	2	3	4	50	0	0	54	100	
07:15:00	60	1	0	0	61	1	5	0	1	6	1	59	0	1	60	127	
07:30:00	43	0	0	3	43	3	6	0	2	9	4	80	0	0	84	136	
07:45:00	73	2	0	0	75	1	8	0	0	9	1	81	0	1	82	166	529
08:00:00	80	2	1	0	83	5	4	0	2	9	9	107	0	0	116	208	637
08:15:00	101	4	0	0	105	4	8	0	0	12	6	138	0	0	144	261	771
08:30:00	115	3	0	1	118	0	7	0	6	7	5	128	0	0	133	258	893
08:45:00	116	5	0	0	121	4	3	0	2	7	8	142	0	1	150	278	1005
09:00:00	111	3	0	0	114	5	7	0	2	12	5	104	0	0	109	235	1032
09:15:00	98	2	0	0	100	2	3	0	0	5	6	90	0	0	96	201	972
09:30:00	96	4	0	0	100	1	1	0	2	2	4	77	0	0	81	183	897
09:45:00	88	0	0	0	88	4	2	0	0	6	5	61	0	0	66	160	779
BREAK																	
16:00:00	109	0	0	0	109	1	5	0	2	6	8	155	0	1	163	278	
16:15:00	110	3	0	0	113	6	8	0	1	14	8	135	0	1	143	270	
16:30:00	143	3	0	0	146	3	4	0	0	7	5	146	0	2	151	304	
16:45:00	129	0	0	0	129	3	7	0	1	10	8	164	0	1	172	311	1163
17:00:00	127	2	1	0	130	4	8	0	3	12	6	170	0	0	176	318	1203
17:15:00	130	1	0	0	131	5	9	0	5	14	5	134	0	0	139	284	1217
17:30:00	123	3	0	0	126	2	8	0	5	10	8	139	0	0	147	283	1196
17:45:00	126	3	0	0	129	5	5	0	2	10	7	132	0	0	139	278	1163
18:00:00	132	1	0	0	133	4	8	0	2	12	8	134	0	0	142	287	1132
18:15:00	128	4	0	0	132	1	7	0	5	8	5	133	0	0	138	278	1126
18:30:00	119	0	0	0	119	3	6	0	6	9	11	124	0	0	135	263	1106
18:45:00	107	3	0	0	110	2	9	0	1	11	6	154	0	0	160	281	1109
Grand Total	2507	49	2	4	2558	70	140	0	52	210	143	2837	0	8	2980	5748	-
Approach%	98%	1.9%	0.1%	-	-	33.3%	66.7%	0%	-	-	4.8%	95.2%	0%	-	-	-	-
Totals %	43.6%	0.9%	0%	-	44.5%	1.2%	2.4%	0%	-	3.7%	2.5%	49.4%	0%	-	51.8%	-	-
Heavy	54	3	0	-	-	3	3	0	-	-	1	79	0	-	-	-	-
Heavy %	2.2%	6.1%	0%	-	-	4.3%	2.1%	0%	-	-	0.7%	2.8%	0%	-	-	-	-
Bicycles	-	-	-	-	-	-	-	-	-	-	-	-	-	-	-	-	-
Bicycle %	-	-	-	-	-	-	-	-	-	-	-	-	-	-	-	-	-



Peak Hour: 08:15 AM - 09:15 AM Weather: Light Rain (16.77 °C)

Start Time	N Approach QUEEN ST S					E Approach ELLEN ST					S Approach QUEEN ST S				Int. Total (15 min)	
	Thru	Left	UTurn	Peds	Approach Total	Right	Left	UTurn	Peds	Approach Total	Right	Thru	UTurn	Peds		Approach Total
08:15:00	101	4	0	0	105	4	8	0	0	12	6	138	0	0	144	261
08:30:00	115	3	0	1	118	0	7	0	6	7	5	128	0	0	133	258
08:45:00	116	5	0	0	121	4	3	0	2	7	8	142	0	1	150	278
09:00:00	111	3	0	0	114	5	7	0	2	12	5	104	0	0	109	235
Grand Total	443	15	0	1	458	13	25	0	10	38	24	512	0	1	536	1032
Approach%	96.7%	3.3%	0%	-	-	34.2%	65.8%	0%	-	-	4.5%	95.5%	0%	-	-	-
Totals %	42.9%	1.5%	0%	44.4%	1.3%	2.4%	0%	3.7%	2.3%	49.6%	0%	51.9%	-	-	-	-
PHF	0.95	0.75	0	0.95	0.65	0.78	0	0.79	0.75	0.9	0	0.89	-	-	-	-
Heavy	17	1	0	18	1	0	0	1	1	20	0	21	-	-	-	-
Heavy %	3.8%	6.7%	0%	3.9%	7.7%	0%	0%	2.6%	4.2%	3.9%	0%	3.9%	-	-	-	-
Lights	426	14	0	440	12	25	0	37	23	492	0	515	-	-	-	-
Lights %	96.2%	93.3%	0%	96.1%	92.3%	100%	0%	97.4%	95.8%	96.1%	0%	96.1%	-	-	-	-
Single-Unit Trucks	7	1	0	8	0	0	0	0	0	3	0	3	-	-	-	-
Single-Unit Trucks %	1.6%	6.7%	0%	1.7%	0%	0%	0%	0%	0%	0.6%	0%	0.6%	-	-	-	-
Buses	8	0	0	8	1	0	0	1	1	15	0	16	-	-	-	-
Buses %	1.8%	0%	0%	1.7%	7.7%	0%	0%	2.6%	4.2%	2.9%	0%	3%	-	-	-	-
Articulated Trucks	2	0	0	2	0	0	0	0	0	2	0	2	-	-	-	-
Articulated Trucks %	0.5%	0%	0%	0.4%	0%	0%	0%	0%	0%	0.4%	0%	0.4%	-	-	-	-
Bicycles on Road	0	0	0	0	0	0	0	0	0	0	0	0	-	-	-	-
Bicycles on Road %	0%	0%	0%	0%	0%	0%	0%	0%	0%	0%	0%	0%	-	-	-	-
Pedestrians	-	-	-	1	-	-	-	10	-	-	-	-	1	-	-	-
Pedestrians%	-	-	-	8.3%	-	-	-	83.3%	-	-	-	8.3%	-	-	-	-
Bicycles on Crosswalk	-	-	-	0	-	-	-	0	-	-	-	0	-	-	-	-
Bicycles on Crosswalk%	-	-	-	0%	-	-	-	0%	-	-	-	0%	-	-	-	-



Peak Hour: 04:30 PM - 05:30 PM Weather: Light Intensity Shower Rain (19.06 °C)

Start Time	N Approach QUEEN ST S					E Approach ELLEN ST					S Approach QUEEN ST S				Int. Total (15 min)	
	Thru	Left	UTurn	Peds	Approach Total	Right	Left	UTurn	Peds	Approach Total	Right	Thru	UTurn	Peds		Approach Total
16:30:00	143	3	0	0	146	3	4	0	0	7	5	146	0	2	151	304
16:45:00	129	0	0	0	129	3	7	0	1	10	8	164	0	1	172	311
17:00:00	127	2	1	0	130	4	8	0	3	12	6	170	0	0	176	318
17:15:00	130	1	0	0	131	5	9	0	5	14	5	134	0	0	139	284
Grand Total	529	6	1	0	536	15	28	0	9	43	24	614	0	3	638	1217
Approach%	98.7%	1.1%	0.2%	-	-	34.9%	65.1%	0%	-	-	3.8%	96.2%	0%	-	-	-
Totals %	43.5%	0.5%	0.1%	-	44%	1.2%	2.3%	0%	-	3.5%	2%	50.5%	0%	-	52.4%	-
PHF	0.92	0.5	0.25	-	0.92	0.75	0.78	0	-	0.77	0.75	0.9	0	-	0.91	-
Heavy	4	0	0	-	4	0	0	0	-	0	0	10	0	-	10	-
Heavy %	0.8%	0%	0%	-	0.7%	0%	0%	0%	-	0%	0%	1.6%	0%	-	1.6%	-
Lights	525	6	1	-	532	15	27	0	-	42	24	604	0	-	628	-
Lights %	99.2%	100%	100%	-	99.3%	100%	96.4%	0%	-	97.7%	100%	98.4%	0%	-	98.4%	-
Single-Unit Trucks	1	0	0	-	1	0	0	0	-	0	0	3	0	-	3	-
Single-Unit Trucks %	0.2%	0%	0%	-	0.2%	0%	0%	0%	-	0%	0%	0.5%	0%	-	0.5%	-
Buses	3	0	0	-	3	0	0	0	-	0	0	5	0	-	5	-
Buses %	0.6%	0%	0%	-	0.6%	0%	0%	0%	-	0%	0%	0.8%	0%	-	0.8%	-
Articulated Trucks	0	0	0	-	0	0	0	0	-	0	0	2	0	-	2	-
Articulated Trucks %	0%	0%	0%	-	0%	0%	0%	0%	-	0%	0%	0.3%	0%	-	0.3%	-
Bicycles on Road	0	0	0	-	0	0	1	0	-	1	0	0	0	-	0	-
Bicycles on Road %	0%	0%	0%	-	0%	0%	3.6%	0%	-	2.3%	0%	0%	0%	-	0%	-
Pedestrians	-	-	-	0	-	-	-	-	8	-	-	-	-	3	-	-
Pedestrians%	-	-	-	0%	-	-	-	-	66.7%	-	-	-	-	25%	-	-
Bicycles on Crosswalk	-	-	-	0	-	-	-	-	1	-	-	-	-	0	-	-
Bicycles on Crosswalk%	-	-	-	0%	-	-	-	-	8.3%	-	-	-	-	0%	-	-

Peak Hour: 08:15 AM - 09:15 AM Weather: Light Rain (16.77 °C)

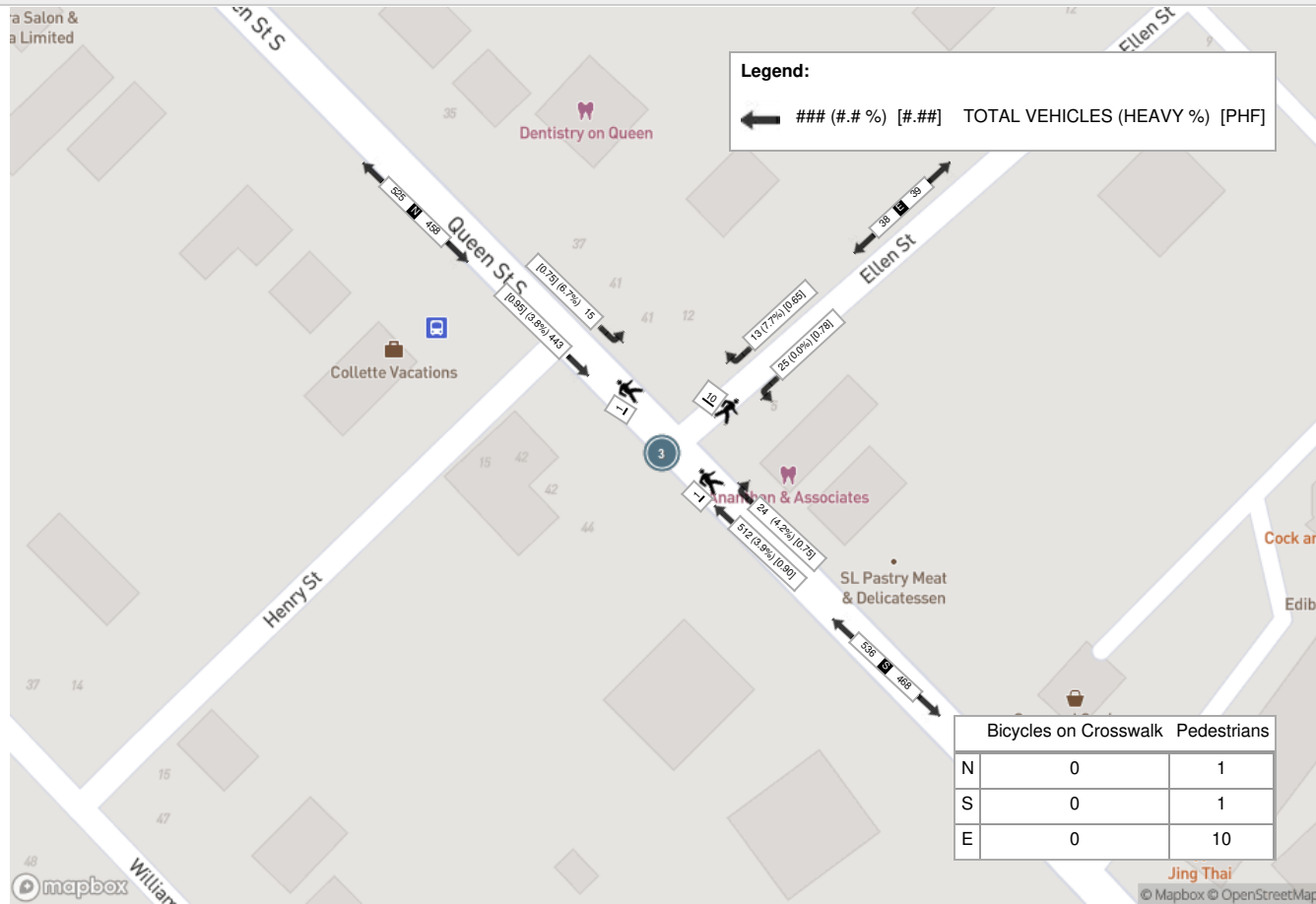

Peak Hour: 04:30 PM - 05:30 PM Weather: Light Intensity Shower Rain (19.06 °C)

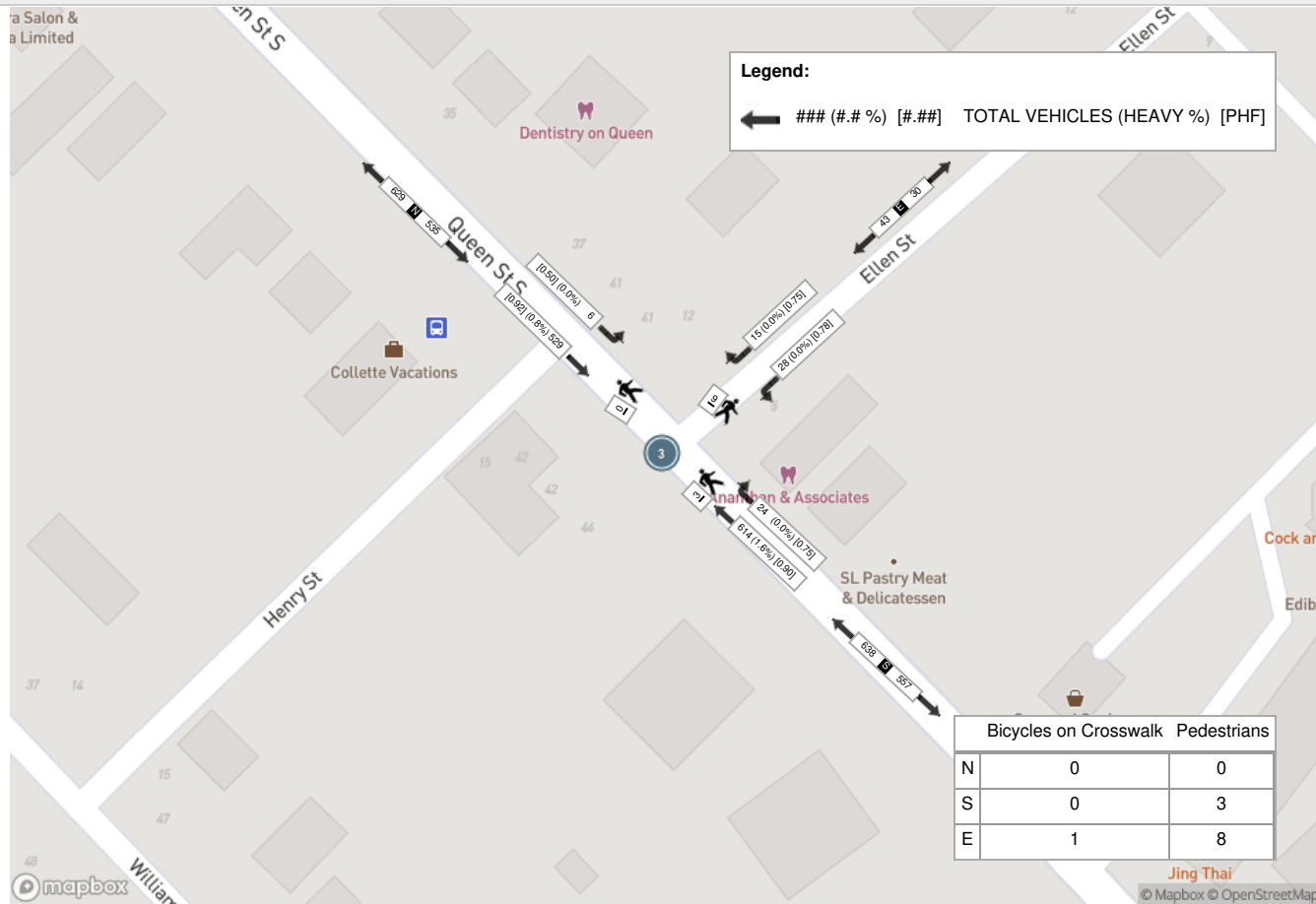



Turning Movement Count (2 . QUEEN ST S & JAMES ST)

Start Time	N Approach QUEEN ST S					S Approach QUEEN ST S					W Approach JAMES ST					Int. Total (15 min)	Int. Total (1 hr)
	Right N:W	Thru N:S	UTurn N:N	Peds N:	Approach Total	Thru S:N	Left S:W	UTurn S:S	Peds S:	Approach Total	Right W:S	Left W:N	UTurn W:W	Peds W:	Approach Total		
07:00:00	1	45	0	0	46	53	0	0	0	53	0	0	0	0	0	99	
07:15:00	2	61	0	0	63	63	0	0	0	63	0	0	0	0	0	126	
07:30:00	1	47	0	0	48	80	0	0	0	80	1	1	0	0	2	130	
07:45:00	2	75	0	1	77	85	0	0	0	85	1	0	0	1	1	163	518
08:00:00	3	85	0	0	88	109	1	0	0	110	0	3	0	2	3	201	620
08:15:00	0	98	0	0	98	144	0	1	0	145	1	3	0	0	4	247	741
08:30:00	2	120	0	0	122	122	0	0	0	122	1	0	0	1	1	245	856
08:45:00	0	120	0	0	120	151	2	0	0	153	0	2	0	3	2	275	968
09:00:00	5	120	0	0	125	114	1	0	0	115	0	2	0	0	2	242	1009
09:15:00	3	103	0	0	106	91	1	0	0	92	0	2	0	2	2	200	962
09:30:00	3	94	0	0	97	79	1	0	0	80	2	1	0	0	3	180	897
09:45:00	2	88	0	0	90	65	0	0	0	65	0	2	0	0	2	157	779
BREAK																	
16:00:00	1	108	0	0	109	149	1	0	0	150	0	1	0	4	1	260	
16:15:00	1	110	0	0	111	145	1	0	0	146	1	4	0	4	5	262	
16:30:00	1	145	0	0	146	148	1	0	0	149	0	1	0	2	1	296	
16:45:00	4	130	0	0	134	162	1	0	0	163	1	1	0	1	2	299	1117
17:00:00	2	126	0	0	128	177	0	0	0	177	0	1	0	0	1	306	1163
17:15:00	2	134	0	0	136	140	2	0	0	142	1	4	0	3	5	283	1184
17:30:00	2	124	0	0	126	143	1	0	0	144	2	0	0	1	2	272	1160
17:45:00	1	124	0	0	125	139	1	0	0	140	1	0	0	4	1	266	1127
18:00:00	1	132	0	0	133	139	2	0	0	141	1	4	0	6	5	279	1100
18:15:00	0	132	0	0	132	130	0	1	0	131	0	0	0	1	0	263	1080
18:30:00	0	118	0	0	118	126	1	0	0	127	1	1	0	2	2	247	1055
18:45:00	1	115	0	0	116	161	0	0	0	161	0	2	0	4	2	279	1068
Grand Total	40	2554	0	1	2594	2915	17	2	0	2934	14	35	0	41	49	5577	-
Approach%	1.5%	98.5%	0%	-	-	99.4%	0.6%	0.1%	-	-	28.6%	71.4%	0%	-	-	-	-
Totals %	0.7%	45.8%	0%	-	46.5%	52.3%	0.3%	0%	-	52.6%	0.3%	0.6%	0%	0.9%	-	-	-
Heavy	5	55	0	-	-	82	1	0	-	-	2	2	0	-	-	-	-
Heavy %	12.5%	2.2%	0%	-	-	2.8%	5.9%	0%	-	-	14.3%	5.7%	0%	-	-	-	-
Bicycles	-	-	-	-	-	-	-	-	-	-	-	-	-	-	-	-	-
Bicycle %	-	-	-	-	-	-	-	-	-	-	-	-	-	-	-	-	-



Peak Hour: 08:15 AM - 09:15 AM Weather: Light Rain (16.77 °C)

Start Time	N Approach QUEEN ST S					S Approach QUEEN ST S					W Approach JAMES ST					Int. Total (15 min)
	Right	Thru	UTurn	Peds	Approach Total	Thru	Left	UTurn	Peds	Approach Total	Right	Left	UTurn	Peds	Approach Total	
08:15:00	0	98	0	0	98	144	0	1	0	145	1	3	0	0	4	247
08:30:00	2	120	0	0	122	122	0	0	0	122	1	0	0	1	1	245
08:45:00	0	120	0	0	120	151	2	0	0	153	0	2	0	3	2	275
09:00:00	5	120	0	0	125	114	1	0	0	115	0	2	0	0	2	242
Grand Total	7	458	0	0	465	531	3	1	0	535	2	7	0	4	9	1009
Approach%	1.5%	98.5%	0%	-	-	99.3%	0.6%	0.2%	-	-	22.2%	77.8%	0%	-	-	-
Totals %	0.7%	45.4%	0%	46.1%	52.6%	0.3%	0.1%	53%	0.2%	0.7%	0%	0.9%	-	-	-	-
PHF	0.35	0.95	0	0.93	0.88	0.38	0.25	0.87	0.5	0.58	0	0.56	-	-	-	-
Heavy	2	19	0	21	23	0	0	23	0	1	0	1	-	-	-	-
Heavy %	28.6%	4.1%	0%	4.5%	4.3%	0%	0%	4.3%	0%	14.3%	0%	11.1%	-	-	-	-
Lights	5	439	0	444	508	3	1	512	2	6	0	8	-	-	-	-
Lights %	71.4%	95.9%	0%	95.5%	95.7%	100%	100%	95.7%	100%	85.7%	0%	88.9%	-	-	-	-
Single-Unit Trucks	1	8	0	9	4	0	0	4	0	0	0	0	-	-	-	-
Single-Unit Trucks %	14.3%	1.7%	0%	1.9%	0.8%	0%	0%	0.7%	0%	0%	0%	0%	-	-	-	-
Buses	1	9	0	10	17	0	0	17	0	1	0	1	-	-	-	-
Buses %	14.3%	2%	0%	2.2%	3.2%	0%	0%	3.2%	0%	14.3%	0%	11.1%	-	-	-	-
Articulated Trucks	0	2	0	2	2	0	0	2	0	0	0	0	-	-	-	-
Articulated Trucks %	0%	0.4%	0%	0.4%	0.4%	0%	0%	0.4%	0%	0%	0%	0%	-	-	-	-
Bicycles on Road	0	0	0	0	0	0	0	0	0	0	0	0	-	-	-	-
Bicycles on Road %	0%	0%	0%	0%	0%	0%	0%	0%	0%	0%	0%	0%	-	-	-	-
Pedestrians	-	-	-	0	-	-	-	0	-	-	-	4	-	-	-	-
Pedestrians%	-	-	-	0%	-	-	-	0%	-	-	-	100%	-	-	-	-
Bicycles on Crosswalk	-	-	-	0	-	-	-	0	-	-	-	0	-	-	-	-
Bicycles on Crosswalk%	-	-	-	0%	-	-	-	0%	-	-	-	0%	-	-	-	-



Peak Hour: 04:30 PM - 05:30 PM Weather: Light Intensity Shower Rain (19.06 °C)

Start Time	N Approach QUEEN ST S					S Approach QUEEN ST S					W Approach JAMES ST					Int. Total (15 min)
	Right	Thru	UTurn	Peds	Approach Total	Thru	Left	UTurn	Peds	Approach Total	Right	Left	UTurn	Peds	Approach Total	
16:30:00	1	145	0	0	146	148	1	0	0	149	0	1	0	2	1	296
16:45:00	4	130	0	0	134	162	1	0	0	163	1	1	0	1	2	299
17:00:00	2	126	0	0	128	177	0	0	0	177	0	1	0	0	1	306
17:15:00	2	134	0	0	136	140	2	0	0	142	1	4	0	3	5	283
Grand Total	9	535	0	0	544	627	4	0	0	631	2	7	0	6	9	1184
Approach%	1.7%	98.3%	0%		-	99.4%	0.6%	0%		-	22.2%	77.8%	0%		-	-
Totals %	0.8%	45.2%	0%		45.9%	53%	0.3%	0%		53.3%	0.2%	0.6%	0%		0.8%	-
PHF	0.56	0.92	0		0.93	0.89	0.5	0		0.89	0.5	0.44	0		0.45	-
Heavy	0	4	0		4	10	0	0		10	0	0	0		0	-
Heavy %	0%	0.7%	0%		0.7%	1.6%	0%	0%		1.6%	0%	0%	0%		0%	-
Lights	9	531	0		540	617	4	0		621	2	7	0		9	-
Lights %	100%	99.3%	0%		99.3%	98.4%	100%	0%		98.4%	100%	100%	0%		100%	-
Single-Unit Trucks	0	1	0		1	3	0	0		3	0	0	0		0	-
Single-Unit Trucks %	0%	0.2%	0%		0.2%	0.5%	0%	0%		0.5%	0%	0%	0%		0%	-
Buses	0	3	0		3	5	0	0		5	0	0	0		0	-
Buses %	0%	0.6%	0%		0.6%	0.8%	0%	0%		0.8%	0%	0%	0%		0%	-
Articulated Trucks	0	0	0		0	2	0	0		2	0	0	0		0	-
Articulated Trucks %	0%	0%	0%		0%	0.3%	0%	0%		0.3%	0%	0%	0%		0%	-
Bicycles on Road	0	0	0		0	0	0	0		0	0	0	0		0	-
Bicycles on Road %	0%	0%	0%		0%	0%	0%	0%		0%	0%	0%	0%		0%	-
Pedestrians	-	-	-	0	-	-	-	0		-	-	-	6		-	-
Pedestrians%	-	-	-	0%	-	-	-	0%		-	-	-	100%		-	-
Bicycles on Crosswalk	-	-	-	0	-	-	-	0		-	-	-	0		-	-
Bicycles on Crosswalk%	-	-	-	0%	-	-	-	0%		-	-	-	0%		-	-

Peak Hour: 08:15 AM - 09:15 AM Weather: Light Rain (16.77 °C)



Peak Hour: 04:30 PM - 05:30 PM Weather: Light Intensity Shower Rain (19.06 °C)



Appendix B

Existing Traffic Level of Service Calculations

Lanes, Volumes, Timings

















3: Queen Street S/Queen Street N & Britannia Road W

01-17-2023

Lane Group	EBL	EBT	EBR	WBL	WBT	WBR	NBL	NBT	NBR	SBL	SBT	SBR
Lane Configurations												
Traffic Volume (vph)	199	1326	109	95	675	198	96	357	85	129	261	139
Future Volume (vph)	199	1326	109	95	675	198	96	357	85	129	261	139
Ideal Flow (vphpl)	1900	1900	1900	1900	1900	1900	1900	1900	1900	1900	1900	1900
Lane Width (m)	3.5	3.5	3.5	3.5	3.5	3.5	3.5	3.5	3.5	3.5	3.5	3.5
Grade (%)		0%			0%			0%			0%	
Storage Length (m)	130.0		0.0	60.0		40.0	40.0		0.0	65.0		65.0
Storage Lanes	1		0	1		1	1		0	1		1
Taper Length (m)	7.5			7.5			7.5			7.5		
Satd. Flow (prot)	1733	3383	0	1716	3336	1483	1594	3385	0	1668	1807	1511
Flt Permitted	0.312			0.082			0.488			0.174		
Satd. Flow (perm)	567	3383	0	148	3336	1440	810	3385	0	304	1807	1470
Right Turn on Red			Yes			Yes			Yes			Yes
Satd. Flow (RTOR)		8				141		19				146
Link Speed (k/h)		50			50			40				40
Link Distance (m)		284.8			253.5			169.0				136.3
Travel Time (s)		20.5			18.3			15.2				12.3
Confl. Peds. (#/hr)	10		6	6		10	10		7	7		10
Confl. Bikes (#/hr)												
Peak Hour Factor	0.95	0.95	0.95	0.95	0.95	0.95	0.95	0.95	0.95	0.95	0.95	0.95
Growth Factor	100%	100%	100%	100%	100%	100%	100%	100%	100%	100%	100%	100%
Heavy Vehicles (%)	3%	4%	5%	4%	7%	6%	12%	1%	6%	7%	4%	4%
Bus Blockages (#/hr)	0	0	4	0	0	4	0	0	4	0	0	4
Parking (#/hr)												
Mid-Block Traffic (%)		0%			0%			0%			0%	
Adj. Flow (vph)	209	1396	115	100	711	208	101	376	89	136	275	146
Shared Lane Traffic (%)												
Lane Group Flow (vph)	209	1511	0	100	711	208	101	465	0	136	275	146
Enter Blocked Intersection	No	No	No	No	No	No	No	No	No	No	No	No
Lane Alignment	Left	Left	Right	Left	Left	Right	Left	Left	Right	Left	Left	Right
Median Width(m)		3.5			3.5			3.5			3.5	
Link Offset(m)		0.0			0.0			0.0			0.0	
Crosswalk Width(m)		4.8			4.8			4.8			4.8	
Two way Left Turn Lane												
Headway Factor	1.01	1.01	1.01	1.01	1.01	1.04	1.01	1.01	1.01	1.01	1.01	1.04
Turning Speed (k/h)	25		15	25		15	25		15	25		15
Turn Type	pm+pt	NA		pm+pt	NA	Perm	Perm	NA		pm+pt	NA	Perm
Protected Phases	5	2		1	6			4		3	8	
Permitted Phases	2			6		6	4			8		8
Detector Phase	5	2		1	6	6	4	4		3	8	8
Switch Phase												
Minimum Initial (s)	8.0	12.0		8.0	12.0	12.0	12.0	12.0		8.0	12.0	12.0
Minimum Split (s)	11.0	35.1		11.0	35.1	35.1	38.9	38.9		11.0	38.9	38.9
Total Split (s)	13.0	83.0		11.0	81.0	81.0	53.0	53.0		13.0	66.0	66.0
Total Split (%)	8.1%	51.9%		6.9%	50.6%	50.6%	33.1%	33.1%		8.1%	41.3%	41.3%
Maximum Green (s)	10.0	75.9		8.0	73.9	73.9	45.1	45.1		10.0	58.1	58.1
Yellow Time (s)	3.0	4.0		3.0	4.0	4.0	4.0	4.0		3.0	4.0	4.0
All-Red Time (s)	0.0	3.1		0.0	3.1	3.1	3.9	3.9		0.0	3.9	3.9
Lost Time Adjust (s)	-1.0	-5.0		-1.0	-5.0	-1.0	-1.0	-5.0		-1.0	-5.0	-1.0

HCM Unsignalized Intersection Capacity Analysis
 6: Queen Street S & Private Access/Ellen Street

01-17-2023

												
Movement	EBL	EBT	EBR	WBL	WBT	WBR	NBL	NBT	NBR	SBL	SBT	SBR
Lane Configurations												
Traffic Volume (veh/h)	2	0	1	25	0	13	3	519	24	15	438	7
Future Volume (Veh/h)	2	0	1	25	0	13	3	519	24	15	438	7
Sign Control		Stop			Stop			Free			Free	
Grade		0%			0%			0%			0%	
Peak Hour Factor	0.95	0.95	0.95	0.95	0.95	0.95	0.95	0.95	0.95	0.95	0.95	0.95
Hourly flow rate (vph)	2	0	1	26	0	14	3	546	25	16	461	7
Pedestrians					10			1			1	
Lane Width (m)					3.5			3.5			3.5	
Walking Speed (m/s)					1.2			1.2			1.2	
Percent Blockage					1			0			0	
Right turn flare (veh)												
Median type								None			None	
Median storage veh												
Upstream signal (m)											331	
pX, platoon unblocked	0.88	0.88	0.88	0.88	0.88		0.88					
vC, conflicting volume	1076	1084	466	1073	1074	570	468			581		
vC1, stage 1 conf vol												
vC2, stage 2 conf vol												
vCu, unblocked vol	1020	1029	330	1017	1019	570	333			581		
tC, single (s)	7.6	6.5	6.2	7.1	6.5	6.3	4.4			4.2		
tC, 2 stage (s)												
tF (s)	4.0	4.0	3.3	3.5	4.0	3.4	2.5			2.3		
p0 queue free %	99	100	100	86	100	97	100			98		
cM capacity (veh/h)	148	203	633	187	205	506	948			961		
Direction, Lane #	EB 1	WB 1	NB 1	SB 1								
Volume Total	3	40	574	484								
Volume Left	2	26	3	16								
Volume Right	1	14	25	7								
cSH	198	239	948	961								
Volume to Capacity	0.02	0.17	0.00	0.02								
Queue Length 95th (m)	0.4	4.7	0.1	0.4								
Control Delay (s)	23.4	23.0	0.1	0.5								
Lane LOS	C	C	A	A								
Approach Delay (s)	23.4	23.0	0.1	0.5								
Approach LOS	C	C										
Intersection Summary												
Average Delay			1.2									
Intersection Capacity Utilization			44.3%		ICU Level of Service				A			
Analysis Period (min)			15									

HCM Unsignalized Intersection Capacity Analysis

9: Queen Street S & James Street

01-17-2023



Movement	EBL	EBR	NBL	NBT	SBT	SBR
Lane Configurations						
Traffic Volume (veh/h)	7	2	3	529	458	7
Future Volume (Veh/h)	7	2	3	529	458	7
Sign Control	Stop			Free	Free	
Grade	0%			0%	0%	
Peak Hour Factor	0.93	0.93	0.93	0.93	0.93	0.93
Hourly flow rate (vph)	8	2	3	569	492	8
Pedestrians	4					
Lane Width (m)	3.5					
Walking Speed (m/s)	1.2					
Percent Blockage	0					
Right turn flare (veh)						
Median type				None	None	
Median storage (veh)						
Upstream signal (m)					169	
pX, platoon unblocked	0.87	0.87	0.87			
vC, conflicting volume	1075	500	504			
vC1, stage 1 conf vol						
vC2, stage 2 conf vol						
vCu, unblocked vol	1013	354	358			
tC, single (s)	6.5	6.2	4.1			
tC, 2 stage (s)						
tF (s)	3.6	3.3	2.2			
p0 queue free %	96	100	100			
cM capacity (veh/h)	218	604	1053			
Direction, Lane #	EB 1	NB 1	SB 1			
Volume Total	10	572	500			
Volume Left	8	3	0			
Volume Right	2	0	8			
cSH	250	1053	1700			
Volume to Capacity	0.04	0.00	0.29			
Queue Length 95th (m)	1.0	0.1	0.0			
Control Delay (s)	20.0	0.1	0.0			
Lane LOS	C	A				
Approach Delay (s)	20.0	0.1	0.0			
Approach LOS	C					
Intersection Summary						
Average Delay			0.2			
Intersection Capacity Utilization			40.2%	ICU Level of Service	A	
Analysis Period (min)			15			

HCM Unsignalized Intersection Capacity Analysis

10: William Street & James Street

01-17-2023

























Movement	WBL	WBR	NBT	NBR	SBL	SBT
Lane Configurations	↶		↷			↷
Traffic Volume (veh/h)	10	0	0	9	0	1
Future Volume (Veh/h)	10	0	0	9	0	1
Sign Control	Stop		Free		Free	
Grade	0%		0%		0%	
Peak Hour Factor	0.88	0.88	0.88	0.88	0.88	0.88
Hourly flow rate (vph)	11	0	0	10	0	1
Pedestrians	1					
Lane Width (m)	3.5					
Walking Speed (m/s)	1.2					
Percent Blockage	0					
Right turn flare (veh)						
Median type	None			None		
Median storage veh						
Upstream signal (m)						
pX, platoon unblocked						
vC, conflicting volume	7	6			11	
vC1, stage 1 conf vol						
vC2, stage 2 conf vol						
vCu, unblocked vol	7	6			11	
tC, single (s)	6.6	6.2			4.1	
tC, 2 stage (s)						
tF (s)	3.7	3.3			2.2	
p0 queue free %	99	100			100	
cM capacity (veh/h)	976	1082			1620	
Direction, Lane #	WB 1	NB 1	SB 1			
Volume Total	11	10	1			
Volume Left	11	0	0			
Volume Right	0	10	0			
cSH	976	1700	1620			
Volume to Capacity	0.01	0.01	0.00			
Queue Length 95th (m)	0.3	0.0	0.0			
Control Delay (s)	8.7	0.0	0.0			
Lane LOS	A					
Approach Delay (s)	8.7	0.0	0.0			
Approach LOS	A					
Intersection Summary						
Average Delay			4.4			
Intersection Capacity Utilization			13.7%	ICU Level of Service	A	
Analysis Period (min)			15			

Lanes, Volumes, Timings

3: Queen Street S/Queen Street N & Britannia Road W

01-17-2023

												
Lane Group	EBL	EBT	EBR	WBL	WBT	WBR	NBL	NBT	NBR	SBL	SBT	SBR
Lane Configurations												
Traffic Volume (vph)	117	828	129	113	1334	101	168	338	128	197	302	176
Future Volume (vph)	117	828	129	113	1334	101	168	338	128	197	302	176
Ideal Flow (vphpl)	1900	1900	1900	1900	1900	1900	1900	1900	1900	1900	1900	1900
Lane Width (m)	3.5	3.5	3.5	3.5	3.5	3.5	3.5	3.5	3.5	3.5	3.5	3.5
Grade (%)		0%			0%			0%			0%	
Storage Length (m)	130.0		0.0	60.0		40.0	40.0		0.0	65.0		65.0
Storage Lanes	1		0	1		1	1		0	1		1
Taper Length (m)	7.5			7.5			7.5			7.5		
Satd. Flow (prot)	1733	3387	0	1785	3500	1541	1750	3306	0	1750	1860	1541
Flt Permitted	0.074			0.195			0.200			0.188		
Satd. Flow (perm)	135	3387	0	366	3500	1489	365	3306	0	341	1860	1496
Right Turn on Red			Yes			Yes			Yes			Yes
Satd. Flow (RTOR)		14				74		37				142
Link Speed (k/h)		50			50			40				40
Link Distance (m)		284.8			253.5			169.0				136.3
Travel Time (s)		20.5			18.3			15.2				12.3
Confl. Peds. (#/hr)	13		11	11		13	11		28	28		11
Confl. Bikes (#/hr)												
Peak Hour Factor	0.94	0.94	0.94	0.94	0.94	0.94	0.94	0.94	0.94	0.94	0.94	0.94
Growth Factor	100%	100%	100%	100%	100%	100%	100%	100%	100%	100%	100%	100%
Heavy Vehicles (%)	3%	3%	0%	0%	2%	2%	2%	2%	2%	2%	1%	2%
Bus Blockages (#/hr)	0	0	4	0	0	4	0	0	4	0	0	4
Parking (#/hr)												
Mid-Block Traffic (%)		0%			0%			0%			0%	
Adj. Flow (vph)	124	881	137	120	1419	107	179	360	136	210	321	187
Shared Lane Traffic (%)												
Lane Group Flow (vph)	124	1018	0	120	1419	107	179	496	0	210	321	187
Enter Blocked Intersection	No	No	No	No	No	No	No	No	No	No	No	No
Lane Alignment	Left	Left	Right	Left	Left	Right	Left	Left	Right	Left	Left	Right
Median Width(m)		3.5			3.5			3.5			3.5	
Link Offset(m)		0.0			0.0			0.0			0.0	
Crosswalk Width(m)		4.8			4.8			4.8			4.8	
Two way Left Turn Lane												
Headway Factor	1.01	1.01	1.01	1.01	1.01	1.04	1.01	1.01	1.01	1.01	1.01	1.04
Turning Speed (k/h)	25		15	25		15	25		15	25		15
Turn Type	pm+pt	NA		pm+pt	NA	Perm	pm+pt	NA		pm+pt	NA	Perm
Protected Phases	5	2		1	6		7	4		3	8	
Permitted Phases	2			6		6	4			8		8
Detector Phase	5	2		1	6	6	7	4		3	8	8
Switch Phase												
Minimum Initial (s)	8.0	12.0		8.0	12.0	12.0	8.0	12.0		8.0	12.0	12.0
Minimum Split (s)	11.0	35.1		11.0	35.1	35.1	11.0	38.9		11.0	38.9	38.9
Total Split (s)	13.0	74.0		11.0	72.0	72.0	14.0	58.0		17.0	61.0	61.0
Total Split (%)	8.1%	46.3%		6.9%	45.0%	45.0%	8.8%	36.3%		10.6%	38.1%	38.1%
Maximum Green (s)	10.0	66.9		8.0	64.9	64.9	11.0	50.1		14.0	53.1	53.1
Yellow Time (s)	3.0	4.0		3.0	4.0	4.0	3.0	4.0		3.0	4.0	4.0
All-Red Time (s)	0.0	3.1		0.0	3.1	3.1	0.0	3.9		0.0	3.9	3.9
Lost Time Adjust (s)	-1.0	-5.0		-1.0	-5.0	-1.0	-1.0	-5.0		-1.0	-5.0	-1.0

Lanes, Volumes, Timings

3: Queen Street S/Queen Street N & Britannia Road W

01-17-2023



Lane Group	EBL	EBT	EBR	WBL	WBT	WBR	NBL	NBT	NBR	SBL	SBT	SBR
Total Lost Time (s)	2.0	2.1		2.0	2.1	6.1	2.0	2.9		2.0	2.9	6.9
Lead/Lag	Lead	Lag		Lead	Lag	Lag	Lead	Lag		Lead	Lag	Lag
Lead-Lag Optimize?	Yes	Yes		Yes	Yes	Yes	Yes	Yes		Yes	Yes	Yes
Vehicle Extension (s)	3.0	3.0		3.0	3.0	3.0	3.0	3.0		3.0	3.0	3.0
Minimum Gap (s)	3.0	3.0		3.0	3.0	3.0	3.0	3.0		3.0	3.0	3.0
Time Before Reduce (s)	0.0	0.0		0.0	0.0	0.0	0.0	0.0		0.0	0.0	0.0
Time To Reduce (s)	0.0	0.0		0.0	0.0	0.0	0.0	0.0		0.0	0.0	0.0
Recall Mode	None	C-Max		None	Max	Max	None	None		None	None	None
Walk Time (s)		8.0			8.0	8.0		9.0			9.0	9.0
Flash Dont Walk (s)		20.0			20.0	20.0		22.0			22.0	22.0
Pedestrian Calls (#/hr)		0			0	0		0			0	0
Act Effct Green (s)	101.8	89.4		98.3	87.2	83.2	48.5	35.6		53.5	38.6	34.6
Actuated g/C Ratio	0.64	0.56		0.61	0.54	0.52	0.30	0.22		0.33	0.24	0.22
v/c Ratio	0.57	0.54		0.37	0.74	0.13	0.84	0.65		0.85	0.72	0.43
Control Delay	29.2	24.5		15.8	32.7	9.3	71.0	55.6		70.2	64.3	16.6
Queue Delay	0.0	0.0		0.0	0.0	0.0	0.0	0.0		0.0	0.0	0.0
Total Delay	29.2	24.5		15.8	32.7	9.3	71.0	55.6		70.2	64.3	16.6
LOS	C	C		B	C	A	E	E		E	E	B
Approach Delay		25.0			29.9			59.7			53.6	
Approach LOS		C			C			E			D	
Queue Length 50th (m)	15.2	107.3		14.7	183.9	5.3	44.7	74.6		53.4	99.7	12.3
Queue Length 95th (m)	39.3	154.3		28.1	265.9	19.5	#67.1	87.5		#72.6	125.3	34.1
Internal Link Dist (m)		260.8			229.5			145.0			112.3	
Turn Bay Length (m)	130.0			60.0		40.0	40.0			65.0		65.0
Base Capacity (vph)	224	1897		322	1907	809	214	1162		246	675	599
Starvation Cap Reductn	0	0		0	0	0	0	0		0	0	0
Spillback Cap Reductn	0	0		0	0	0	0	0		0	0	0
Storage Cap Reductn	0	0		0	0	0	0	0		0	0	0
Reduced v/c Ratio	0.55	0.54		0.37	0.74	0.13	0.84	0.43		0.85	0.48	0.31

Intersection Summary

Area Type: Other
 Cycle Length: 160
 Actuated Cycle Length: 160
 Offset: 114 (71%), Referenced to phase 2:EBTL, Start of Green
 Natural Cycle: 100
 Control Type: Actuated-Coordinated
 Maximum v/c Ratio: 0.85
 Intersection Signal Delay: 37.5
 Intersection LOS: D
 Intersection Capacity Utilization 89.0%
 ICU Level of Service E
 Analysis Period (min) 15
 # 95th percentile volume exceeds capacity, queue may be longer.
 Queue shown is maximum after two cycles.

Splits and Phases: 3: Queen Street S/Queen Street N & Britannia Road W

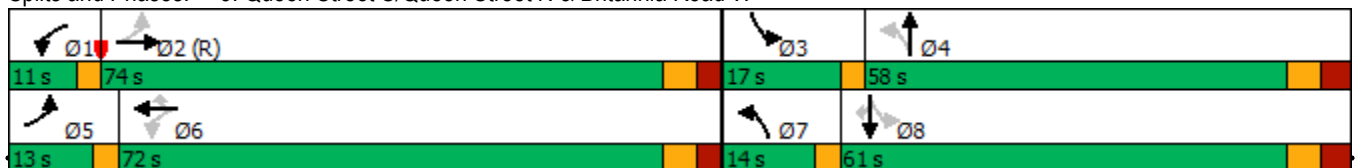

Existing PM Peak 4:44 pm 01-17-2023 Baseline

HCM Unsignalized Intersection Capacity Analysis

6: Queen Street S & Private Access/Ellen Street

01-17-2023



Movement	EBL	EBT	EBR	WBL	WBT	WBR	NBL	NBT	NBR	SBL	SBT	SBR
Lane Configurations		↕			↕			↕			↕	
Traffic Volume (veh/h)	7	0	1	28	0	15	1	609	24	6	523	8
Future Volume (Veh/h)	7	0	1	28	0	15	1	609	24	6	523	8
Sign Control		Stop			Stop			Free			Free	
Grade		0%			0%			0%			0%	
Peak Hour Factor	0.92	0.92	0.92	0.92	0.92	0.92	0.92	0.92	0.92	0.92	0.92	0.92
Hourly flow rate (vph)	8	0	1	30	0	16	1	662	26	7	568	9
Pedestrians		8			9			3				
Lane Width (m)		3.5			3.5			3.5				
Walking Speed (m/s)		1.2			1.2			1.2				
Percent Blockage		1			1			0				
Right turn flare (veh)												
Median type								None			None	
Median storage veh												
Upstream signal (m)												331
pX, platoon unblocked	0.84	0.84	0.84	0.84	0.84		0.84					
vC, conflicting volume	1288	1294	584	1276	1285	684	585			697		
vC1, stage 1 conf vol												
vC2, stage 2 conf vol												
vCu, unblocked vol	1248	1255	415	1235	1245	684	417			697		
tC, single (s)	7.2	6.5	6.2	7.1	6.5	6.2	5.1			4.1		
tC, 2 stage (s)												
tF (s)	3.6	4.0	3.3	3.5	4.0	3.3	3.1			2.2		
p0 queue free %	93	100	100	76	100	96	100			99		
cM capacity (veh/h)	113	143	537	127	145	449	643			902		
Direction, Lane #	EB 1	WB 1	NB 1	SB 1								
Volume Total	9	46	689	584								
Volume Left	8	30	1	7								
Volume Right	1	16	26	9								
cSH	123	169	643	902								
Volume to Capacity	0.07	0.27	0.00	0.01								
Queue Length 95th (m)	1.9	8.4	0.0	0.2								
Control Delay (s)	36.4	34.1	0.0	0.2								
Lane LOS	E	D	A	A								
Approach Delay (s)	36.4	34.1	0.0	0.2								
Approach LOS	E	D										
Intersection Summary												
Average Delay			1.5									
Intersection Capacity Utilization			45.1%		ICU Level of Service					A		
Analysis Period (min)			15									

HCM Unsignalized Intersection Capacity Analysis

9: Queen Street S & James Street

01-17-2023



Movement	EBL	EBR	NBL	NBT	SBT	SBR
Lane Configurations						
Traffic Volume (veh/h)	7	2	4	620	535	9
Future Volume (Veh/h)	7	2	4	620	535	9
Sign Control	Stop			Free	Free	
Grade	0%			0%	0%	
Peak Hour Factor	0.93	0.93	0.93	0.93	0.93	0.93
Hourly flow rate (vph)	8	2	4	667	575	10
Pedestrians	6					
Lane Width (m)	3.5					
Walking Speed (m/s)	1.2					
Percent Blockage	0					
Right turn flare (veh)						
Median type				None	None	
Median storage (veh)						
Upstream signal (m)					169	
pX, platoon unblocked	0.82	0.82	0.82			
vC, conflicting volume	1261	586	591			
vC1, stage 1 conf vol						
vC2, stage 2 conf vol						
vCu, unblocked vol	1210	391	397			
tC, single (s)	6.4	6.2	4.1			
tC, 2 stage (s)						
tF (s)	3.5	3.3	2.2			
p0 queue free %	95	100	100			
cM capacity (veh/h)	166	543	962			
Direction, Lane #	EB 1	NB 1	SB 1			
Volume Total	10	671	585			
Volume Left	8	4	0			
Volume Right	2	0	10			
cSH	193	962	1700			
Volume to Capacity	0.05	0.00	0.34			
Queue Length 95th (m)	1.3	0.1	0.0			
Control Delay (s)	24.7	0.1	0.0			
Lane LOS	C	A				
Approach Delay (s)	24.7	0.1	0.0			
Approach LOS	C					
Intersection Summary						
Average Delay			0.3			
Intersection Capacity Utilization			45.8%	ICU Level of Service	A	
Analysis Period (min)			15			

HCM Unsignalized Intersection Capacity Analysis

10: William Street & James Street

01-17-2023



Movement	WBL	WBR	NBT	NBR	SBL	SBT
Lane Configurations						
Traffic Volume (veh/h)	13	0	1	9	0	0
Future Volume (Veh/h)	13	0	1	9	0	0
Sign Control	Stop		Free		Free	
Grade	0%		0%		0%	
Peak Hour Factor	0.92	0.92	0.92	0.92	0.92	0.92
Hourly flow rate (vph)	14	0	1	10	0	0
Pedestrians						
Lane Width (m)						
Walking Speed (m/s)						
Percent Blockage						
Right turn flare (veh)						
Median type	None			None		
Median storage (veh)						
Upstream signal (m)						
pX, platoon unblocked						
vC, conflicting volume	6	6			11	
vC1, stage 1 conf vol						
vC2, stage 2 conf vol						
vCu, unblocked vol	6	6			11	
tC, single (s)	6.4	6.2			4.1	
tC, 2 stage (s)						
tF (s)	3.5	3.3			2.2	
p0 queue free %	99	100			100	
cM capacity (veh/h)	1021	1083			1621	
Direction, Lane #	WB 1	NB 1	SB 1			
Volume Total	14	11	0			
Volume Left	14	0	0			
Volume Right	0	10	0			
cSH	1021	1700	1700			
Volume to Capacity	0.01	0.01	0.00			
Queue Length 95th (m)	0.3	0.0	0.0			
Control Delay (s)	8.6	0.0	0.0			
Lane LOS	A					
Approach Delay (s)	8.6	0.0	0.0			
Approach LOS	A					
Intersection Summary						
Average Delay			4.8			
Intersection Capacity Utilization			13.3%		ICU Level of Service	A
Analysis Period (min)			15			

Appendix C

Background Development Traffic Volumes and Growth Rates

Nyx Capital Corp

Tannery Street Townhouse
Residential Development

TRANSPORTATION
IMPACT STUDY

18031

June 2019 Update

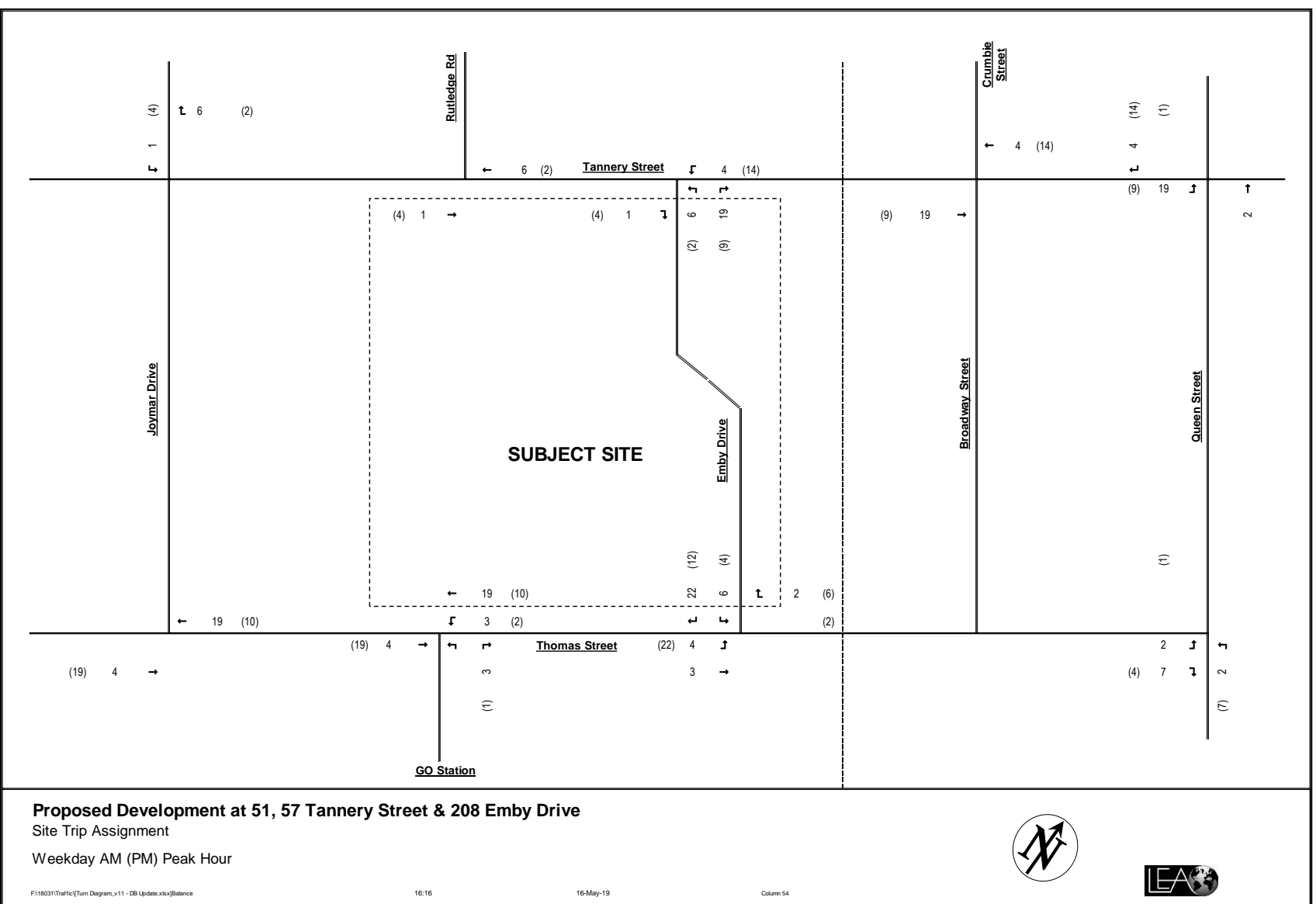
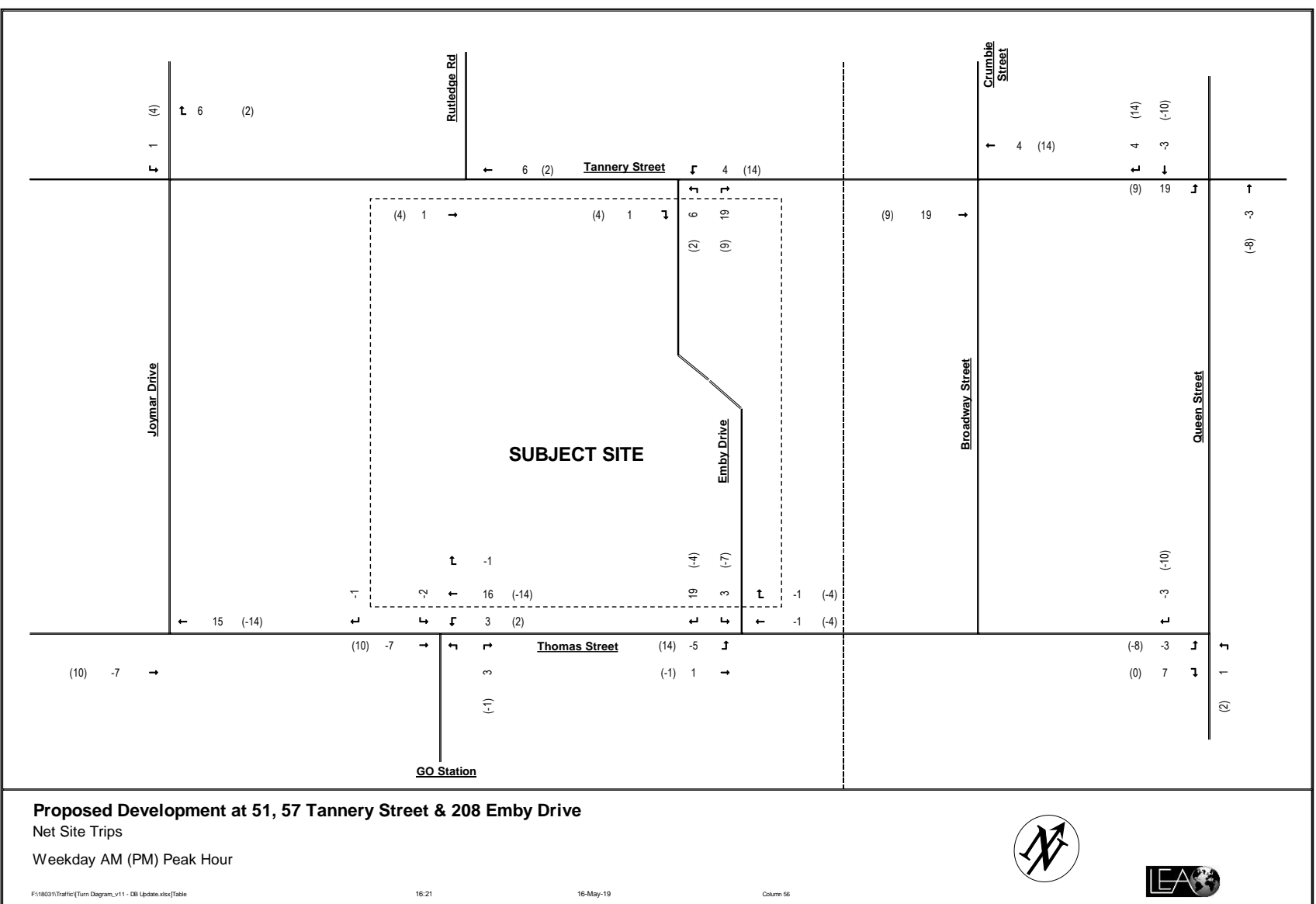

Figure 8: Peak Hour Site Trips

June 2019 Update

LEA Consulting Ltd.





June 2019 Update

LEA Consulting Ltd.



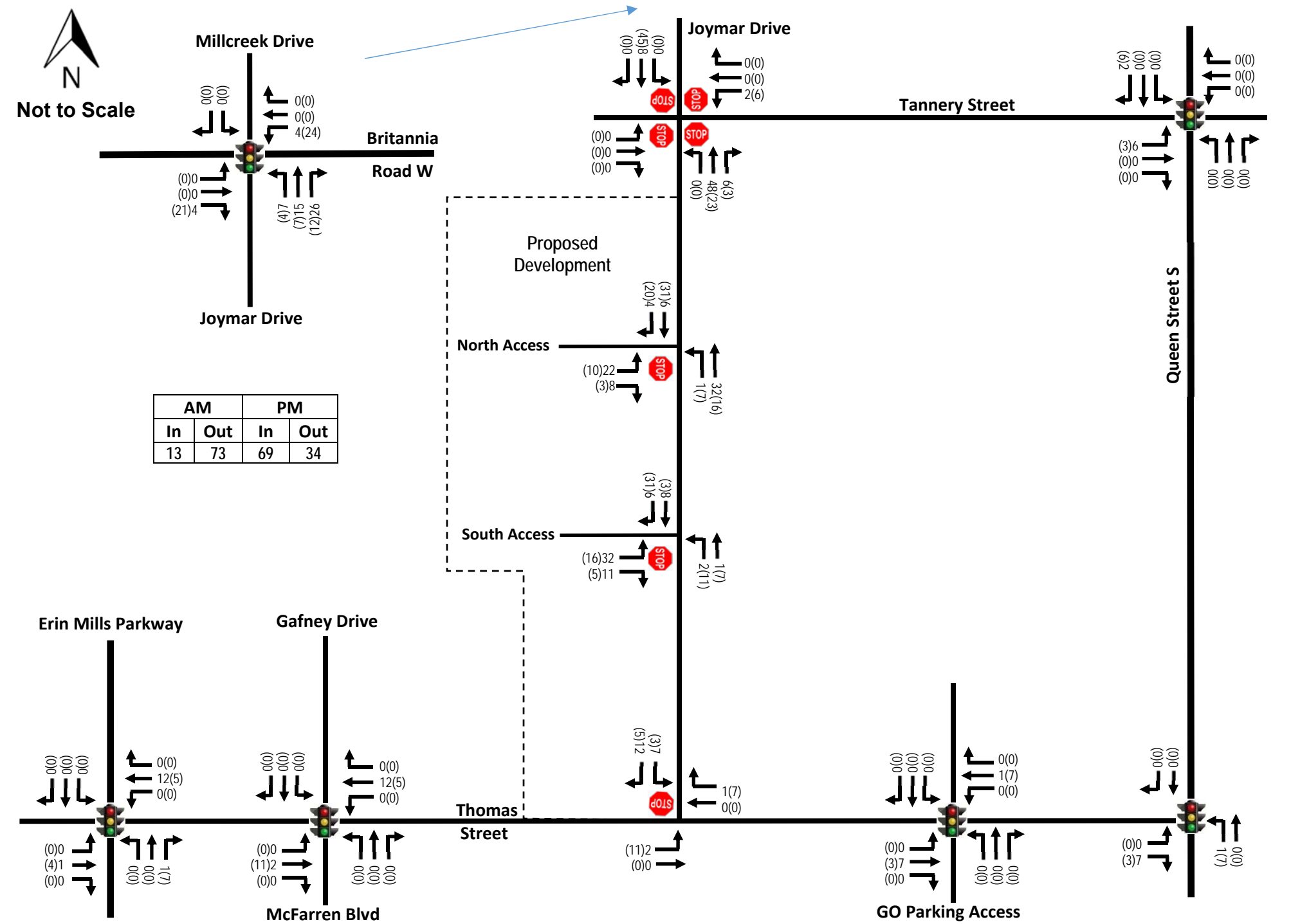

Figure 9 - Site Traffic Volumes

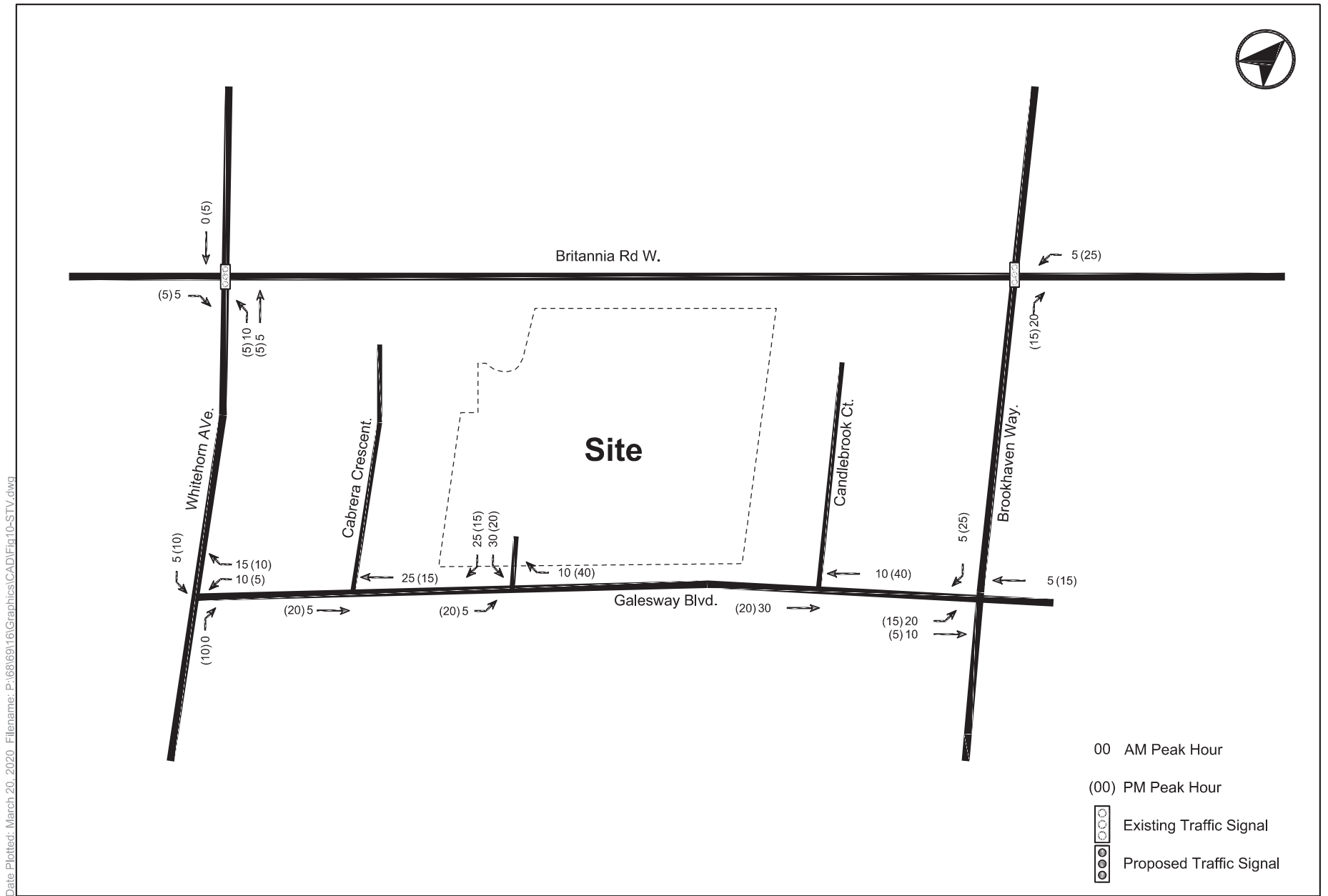
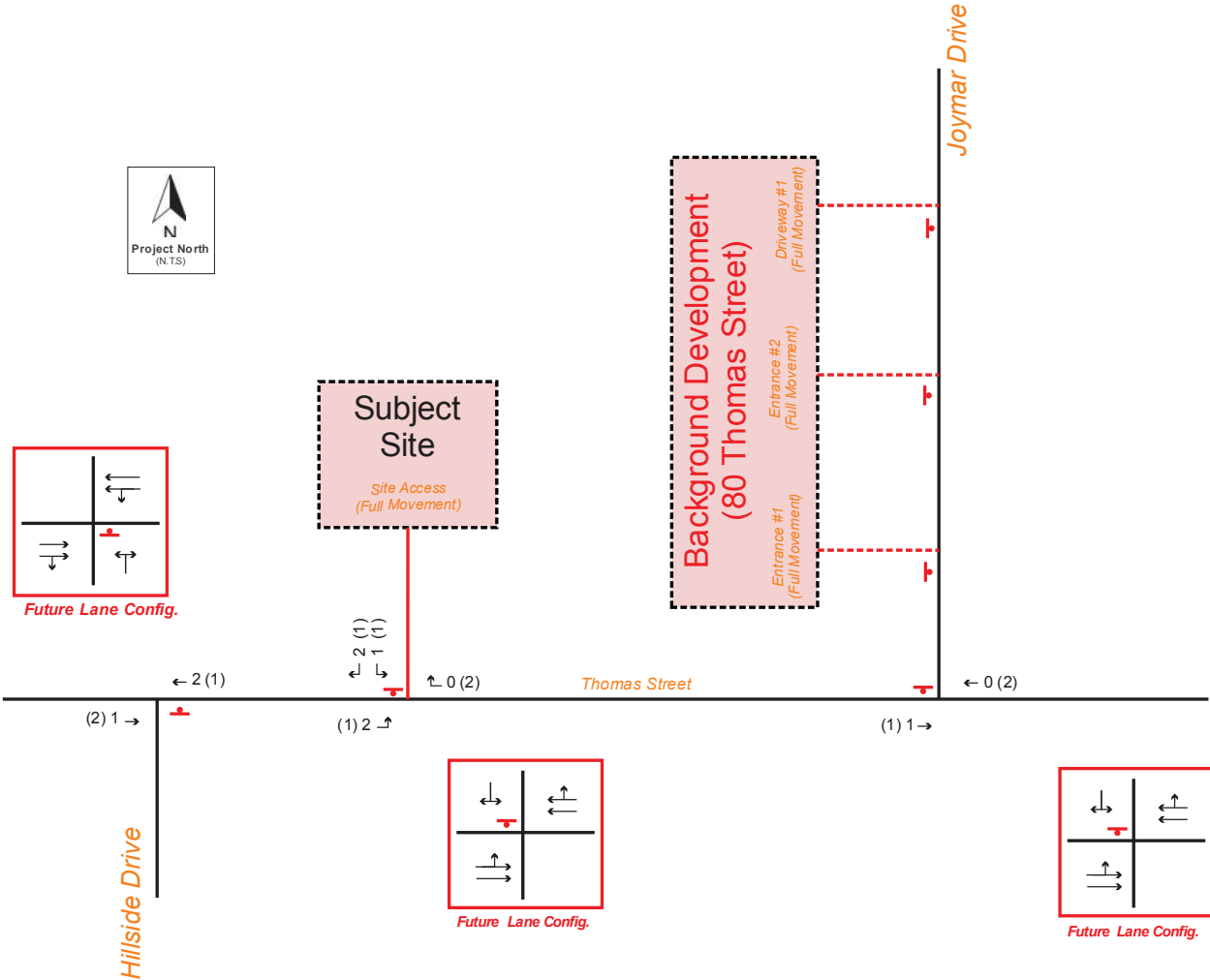

FIGURE 10 SITE TRAFFIC VOLUMES

Figure 4-1 – Site Generated Traffic Volumes



5.0 FUTURE TOTAL TRAFFIC CONDITIONS

The forecasted 2024 future total traffic volumes (future background traffic volumes plus site generated traffic volumes) are illustrated in **Figure 5-1**, and were analyzed using Synchro 10 software. The detailed calculations are provided in **Appendix F** and summarized in **Table 5.1**.

NOTE:
THIS FIGURE IS SCHEMATIC ONLY AND IS NOT TO BE SCALED.

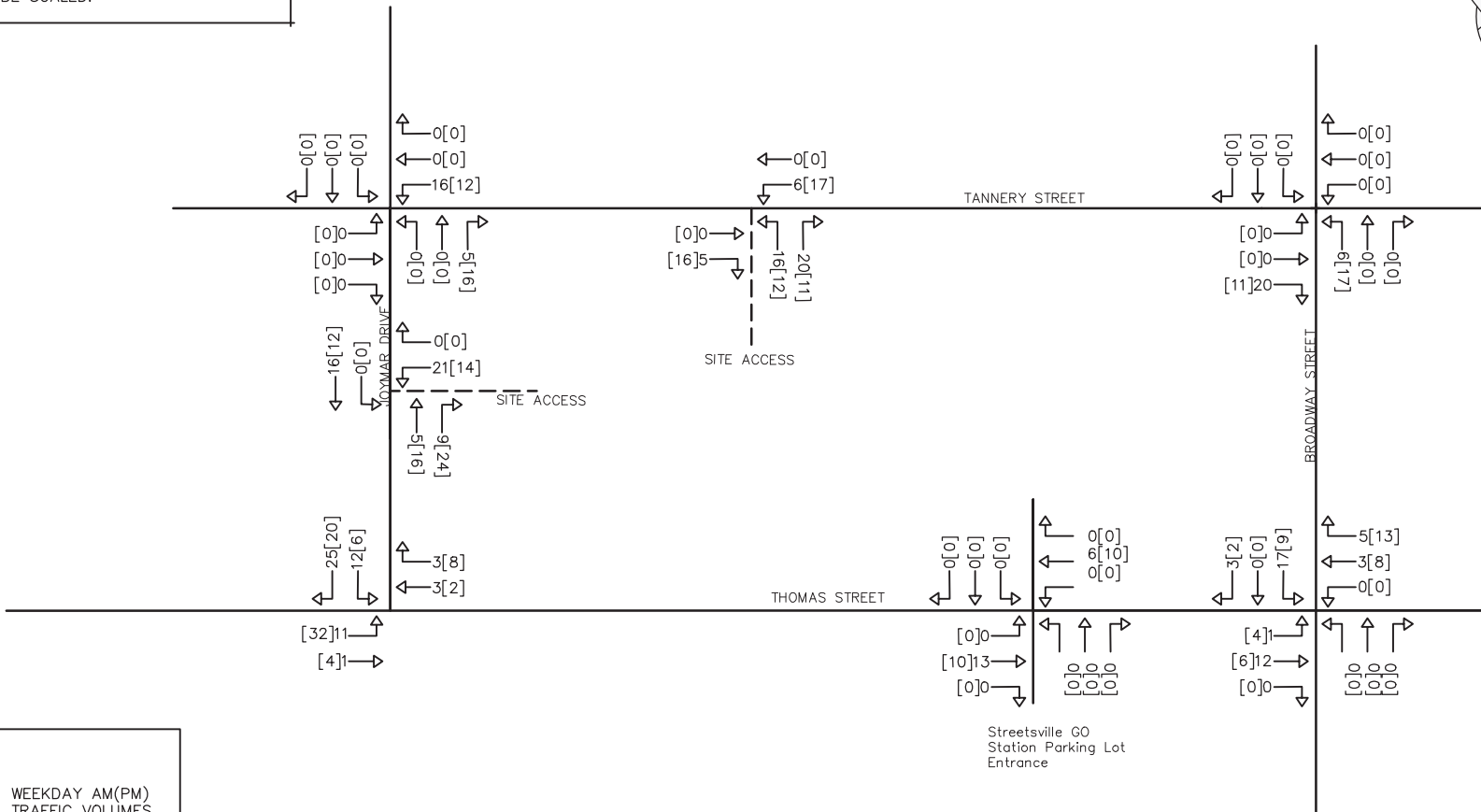
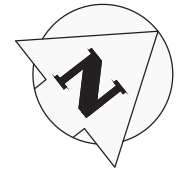

LEGEND:
XX(XX) WEEKDAY AM(PM)
TRAFFIC VOLUMES

66 THOMAS STREET CITY OF MISSISSAUGA

TRIP ASSIGNMENT



CROZIER & ASSOCIATES
Consulting Engineers

2800 HIGH POINT DRIVE
SUITE 100
MILTON, ON L9T 6P4
905 875-0026 T
905 875-4915 F
WWW.CFCROZIER.CA

Drawn	M.B.	Design	K.S.	Project No.	1419-4679
Check	K.S.	Check	K.S.	Scale	N.T.S.
				Dwg.	FIG. 07

66 Queen Street S

ITE Land Use	Magnitude (units)	Parameters	Morning Peak Hour			Afternoon Peak Hour		
			In	Out	Total	In	Out	Total
Multifamily Housing (Low-rise) LUC 220 General Urban/Suburban	10	Trip Rates AM - $\ln(T) = 0.95\ln(X) - 0.51$ PM - $\ln(T) = 0.89\ln(X) - 0.02$	0.12	0.38	0.50	0.5	0.3	0.80
		Total Trips	1	4	5	5	3	8

36, 38, 40, 44, 46 Main Street

ITE Land Use	Magnitude (units)	Parameters	Morning Peak Hour			Afternoon Peak Hour		
			In	Out	Total	In	Out	Total
Multifamily Housing (Low-rise) LUC 220 General Urban/Suburban	26	Trip Rates AM - $\ln(T) = 0.95\ln(X) - 0.51$ PM - $\ln(T) = 0.89\ln(X) - 0.02$	0.12	0.38	0.50	0.43	0.26	0.69
		Total Trips	3	10	13	11	7	18

5155 Mississauga Road

ITE Land Use	Magnitude (units)	Parameters	Morning Peak Hour			Afternoon Peak Hour		
			In	Out	Total	In	Out	Total
Multifamily Housing (Low-rise) LUC 220 General Urban/Suburban	10	Trip Rates AM - $\ln(T) = 0.95\ln(X) - 0.51$ PM - $\ln(T) = 0.89\ln(X) - 0.02$	0.12	0.38	0.50	0.5	0.3	0.80
		Total Trips	1	4	5	5	3	8

Appendix D

Future Background Level of Service Calculations

Lanes, Volumes, Timings

3: Queen Street S/Queen Street N & Britannia Road W

01-17-2023

Lane Group	EBL	EBT	EBR	WBL	WBT	WBR	NBL	NBT	NBR	SBL	SBT	SBR
Lane Configurations												
Traffic Volume (vph)	199	1371	115	100	706	198	96	387	85	129	286	139
Future Volume (vph)	199	1371	115	100	706	198	96	387	85	129	286	139
Ideal Flow (vphpl)	1900	1900	1900	1900	1900	1900	1900	1900	1900	1900	1900	1900
Lane Width (m)	3.5	3.5	3.5	3.5	3.5	3.5	3.5	3.5	3.5	3.5	3.5	3.5
Grade (%)		0%			0%			0%			0%	
Storage Length (m)	130.0		0.0	60.0		40.0	40.0		0.0	65.0		65.0
Storage Lanes	1		0	1		1	1		0	1		1
Taper Length (m)	7.5			7.5			7.5			7.5		
Satd. Flow (prot)	1733	3379	0	1716	3336	1483	1594	3395	0	1668	1807	1511
Flt Permitted	0.296			0.067			0.442			0.163		
Satd. Flow (perm)	538	3379	0	121	3336	1440	734	3395	0	285	1807	1470
Right Turn on Red			Yes			Yes			Yes			Yes
Satd. Flow (RTOR)		8				135		17				146
Link Speed (k/h)		50			50			40				40
Link Distance (m)		284.8			253.5			169.0				136.3
Travel Time (s)		20.5			18.3			15.2				12.3
Confl. Peds. (#/hr)	10		6	6		10	10		7	7		10
Confl. Bikes (#/hr)												
Peak Hour Factor	0.95	0.95	0.95	0.95	0.95	0.95	0.95	0.95	0.95	0.95	0.95	0.95
Growth Factor	100%	100%	100%	100%	100%	100%	100%	100%	100%	100%	100%	100%
Heavy Vehicles (%)	3%	4%	5%	4%	7%	6%	12%	1%	6%	7%	4%	4%
Bus Blockages (#/hr)	0	0	4	0	0	4	0	0	4	0	0	4
Parking (#/hr)												
Mid-Block Traffic (%)		0%			0%			0%			0%	
Adj. Flow (vph)	209	1443	121	105	743	208	101	407	89	136	301	146
Shared Lane Traffic (%)												
Lane Group Flow (vph)	209	1564	0	105	743	208	101	496	0	136	301	146
Enter Blocked Intersection	No	No	No	No	No	No	No	No	No	No	No	No
Lane Alignment	Left	Left	Right	Left	Left	Right	Left	Left	Right	Left	Left	Right
Median Width(m)		3.5			3.5			3.5			3.5	
Link Offset(m)		0.0			0.0			0.0			0.0	
Crosswalk Width(m)		4.8			4.8			4.8			4.8	
Two way Left Turn Lane												
Headway Factor	1.01	1.01	1.01	1.01	1.01	1.04	1.01	1.01	1.01	1.01	1.01	1.04
Turning Speed (k/h)	25		15	25		15	25		15	25		15
Turn Type	pm+pt	NA		pm+pt	NA	Perm	Perm	NA		pm+pt	NA	Perm
Protected Phases	5	2		1	6			4		3	8	
Permitted Phases	2			6		6	4			8		8
Detector Phase	5	2		1	6	6	4	4		3	8	8
Switch Phase												
Minimum Initial (s)	8.0	12.0		8.0	12.0	12.0	12.0	12.0		8.0	12.0	12.0
Minimum Split (s)	11.0	35.1		11.0	35.1	35.1	38.9	38.9		11.0	38.9	38.9
Total Split (s)	13.0	83.0		11.0	81.0	81.0	53.0	53.0		13.0	66.0	66.0
Total Split (%)	8.1%	51.9%		6.9%	50.6%	50.6%	33.1%	33.1%		8.1%	41.3%	41.3%
Maximum Green (s)	10.0	75.9		8.0	73.9	73.9	45.1	45.1		10.0	58.1	58.1
Yellow Time (s)	3.0	4.0		3.0	4.0	4.0	4.0	4.0		3.0	4.0	4.0
All-Red Time (s)	0.0	3.1		0.0	3.1	3.1	3.9	3.9		0.0	3.9	3.9
Lost Time Adjust (s)	-1.0	-5.0		-1.0	-5.0	-1.0	-1.0	-5.0		-1.0	-5.0	-1.0

Lanes, Volumes, Timings

3: Queen Street S/Queen Street N & Britannia Road W

01-17-2023



Lane Group	EBL	EBT	EBR	WBL	WBT	WBR	NBL	NBT	NBR	SBL	SBT	SBR
Total Lost Time (s)	2.0	2.1		2.0	2.1	6.1	6.9	2.9		2.0	2.9	6.9
Lead/Lag	Lead	Lag		Lead	Lag	Lag	Lag	Lag		Lead		
Lead-Lag Optimize?	Yes	Yes		Yes	Yes	Yes	Yes	Yes		Yes		
Vehicle Extension (s)	3.0	3.0		3.0	3.0	3.0	3.0	3.0		3.0	3.0	3.0
Minimum Gap (s)	3.0	3.0		3.0	3.0	3.0	3.0	3.0		3.0	3.0	3.0
Time Before Reduce (s)	0.0	0.0		0.0	0.0	0.0	0.0	0.0		0.0	0.0	0.0
Time To Reduce (s)	0.0	0.0		0.0	0.0	0.0	0.0	0.0		0.0	0.0	0.0
Recall Mode	None	C-Max		None	Max	Max	None	None		None	None	None
Walk Time (s)		8.0			8.0	8.0	9.0	9.0			9.0	9.0
Flash Dont Walk (s)		20.0			20.0	20.0	22.0	22.0			22.0	22.0
Pedestrian Calls (#/hr)		0			0	0	0	0			0	0
Act Effct Green (s)	107.9	94.0		105.4	92.7	88.7	29.5	33.5		47.4	46.5	42.5
Actuated g/C Ratio	0.67	0.59		0.66	0.58	0.55	0.18	0.21		0.30	0.29	0.27
v/c Ratio	0.45	0.79		0.51	0.38	0.24	0.75	0.69		0.76	0.57	0.29
Control Delay	13.3	30.2		26.2	20.0	8.2	92.9	61.0		69.2	52.4	7.3
Queue Delay	0.0	0.0		0.0	0.0	0.0	0.0	0.0		0.0	0.0	0.0
Total Delay	13.3	30.2		26.2	20.0	8.2	92.9	61.0		69.2	52.4	7.3
LOS	B	C		C	B	A	F	E		E	D	A
Approach Delay		28.2			18.3			66.4			45.0	
Approach LOS		C			B			E			D	
Queue Length 50th (m)	23.8	201.2		11.2	67.8	11.1	32.5	79.1		35.2	86.5	0.0
Queue Length 95th (m)	40.4	280.2		32.0	98.7	30.6	53.9	94.6		#56.3	112.1	17.1
Internal Link Dist (m)		260.8			229.5			145.0			112.3	
Turn Bay Length (m)	130.0			60.0		40.0	40.0			65.0		65.0
Base Capacity (vph)	468	1988		204	1933	858	211	1074		179	712	635
Starvation Cap Reductn	0	0		0	0	0	0	0		0	0	0
Spillback Cap Reductn	0	0		0	0	0	0	0		0	0	0
Storage Cap Reductn	0	0		0	0	0	0	0		0	0	0
Reduced v/c Ratio	0.45	0.79		0.51	0.38	0.24	0.48	0.46		0.76	0.42	0.23

Intersection Summary

Area Type: Other
 Cycle Length: 160
 Actuated Cycle Length: 160
 Offset: 155 (97%), Referenced to phase 2:EBTL, Start of Green
 Natural Cycle: 110
 Control Type: Actuated-Coordinated
 Maximum v/c Ratio: 0.79
 Intersection Signal Delay: 33.7 Intersection LOS: C
 Intersection Capacity Utilization 92.1% ICU Level of Service F
 Analysis Period (min) 15
 # 95th percentile volume exceeds capacity, queue may be longer.
 Queue shown is maximum after two cycles.

Splits and Phases: 3: Queen Street S/Queen Street N & Britannia Road W

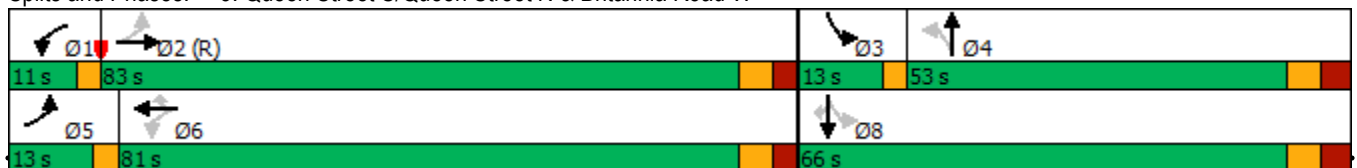

HCM Unsignalized Intersection Capacity Analysis

6: Queen Street S & Private Access/Ellen Street

01-17-2023



Movement	EBL	EBT	EBR	WBL	WBT	WBR	NBL	NBT	NBR	SBL	SBT	SBR
Lane Configurations		↕			↕			↕			↕	
Traffic Volume (veh/h)	2	0	1	25	0	13	3	549	24	15	474	7
Future Volume (Veh/h)	2	0	1	25	0	13	3	549	24	15	474	7
Sign Control		Stop			Stop			Free			Free	
Grade		0%			0%			0%			0%	
Peak Hour Factor	0.95	0.95	0.95	0.95	0.95	0.95	0.95	0.95	0.95	0.95	0.95	0.95
Hourly flow rate (vph)	2	0	1	26	0	14	3	578	25	16	499	7
Pedestrians					10			1			1	
Lane Width (m)					3.5			3.5			3.5	
Walking Speed (m/s)					1.2			1.2			1.2	
Percent Blockage					1			0			0	
Right turn flare (veh)												
Median type								None			None	
Median storage veh												
Upstream signal (m)											331	
pX, platoon unblocked	0.87	0.87	0.87	0.87	0.87		0.87					
vC, conflicting volume	1146	1154	504	1143	1144	602	506			613		
vC1, stage 1 conf vol												
vC2, stage 2 conf vol												
vCu, unblocked vol	1093	1101	353	1089	1091	602	356			613		
tC, single (s)	7.6	6.5	6.2	7.1	6.5	6.3	4.4			4.2		
tC, 2 stage (s)												
tF (s)	4.0	4.0	3.3	3.5	4.0	3.4	2.5			2.3		
p0 queue free %	98	100	100	84	100	97	100			98		
cM capacity (veh/h)	129	180	603	164	183	485	912			935		
Direction, Lane #	EB 1	WB 1	NB 1	SB 1								
Volume Total	3	40	606	522								
Volume Left	2	26	3	16								
Volume Right	1	14	25	7								
cSH	174	213	912	935								
Volume to Capacity	0.02	0.19	0.00	0.02								
Queue Length 95th (m)	0.4	5.4	0.1	0.4								
Control Delay (s)	26.0	25.8	0.1	0.5								
Lane LOS	D	D	A	A								
Approach Delay (s)	26.0	25.8	0.1	0.5								
Approach LOS	D	D										
Intersection Summary												
Average Delay			1.2									
Intersection Capacity Utilization			46.2%		ICU Level of Service					A		
Analysis Period (min)			15									

HCM Unsignalized Intersection Capacity Analysis

9: Queen Street S & James Street

01-17-2023











Movement	EBL	EBR	NBL	NBT	SBT	SBR
Lane Configurations						
Traffic Volume (veh/h)	7	2	3	559	494	7
Future Volume (Veh/h)	7	2	3	559	494	7
Sign Control	Stop			Free	Free	
Grade	0%			0%	0%	
Peak Hour Factor	0.93	0.93	0.93	0.93	0.93	0.93
Hourly flow rate (vph)	8	2	3	601	531	8
Pedestrians	4					
Lane Width (m)	3.5					
Walking Speed (m/s)	1.2					
Percent Blockage	0					
Right turn flare (veh)						
Median type				None	None	
Median storage veh						
Upstream signal (m)					169	
pX, platoon unblocked	0.86	0.86	0.86			
vC, conflicting volume	1146	539	543			
vC1, stage 1 conf vol						
vC2, stage 2 conf vol						
vCu, unblocked vol	1086	376	381			
tC, single (s)	6.5	6.2	4.1			
tC, 2 stage (s)						
tF (s)	3.6	3.3	2.2			
p0 queue free %	96	100	100			
cM capacity (veh/h)	193	575	1013			
Direction, Lane #	EB 1	NB 1	SB 1			
Volume Total	10	604	539			
Volume Left	8	3	0			
Volume Right	2	0	8			
cSH	223	1013	1700			
Volume to Capacity	0.04	0.00	0.32			
Queue Length 95th (m)	1.1	0.1	0.0			
Control Delay (s)	21.9	0.1	0.0			
Lane LOS	C	A				
Approach Delay (s)	21.9	0.1	0.0			
Approach LOS	C					
Intersection Summary						
Average Delay			0.2			
Intersection Capacity Utilization			41.8%	ICU Level of Service	A	
Analysis Period (min)			15			

HCM Unsignalized Intersection Capacity Analysis

10: William Street & James Street

01-17-2023

						
Movement	WBL	WBR	NBT	NBR	SBL	SBT
Lane Configurations						
Traffic Volume (veh/h)	10	0	0	9	0	1
Future Volume (Veh/h)	10	0	0	9	0	1
Sign Control	Stop		Free			Free
Grade	0%		0%			0%
Peak Hour Factor	0.88	0.88	0.88	0.88	0.88	0.88
Hourly flow rate (vph)	11	0	0	10	0	1
Pedestrians	1					
Lane Width (m)	3.5					
Walking Speed (m/s)	1.2					
Percent Blockage	0					
Right turn flare (veh)						
Median type			None			None
Median storage veh						
Upstream signal (m)						
pX, platoon unblocked						
vC, conflicting volume	7	6			11	
vC1, stage 1 conf vol						
vC2, stage 2 conf vol						
vCu, unblocked vol	7	6			11	
tC, single (s)	6.6	6.2			4.1	
tC, 2 stage (s)						
tF (s)	3.7	3.3			2.2	
p0 queue free %	99	100			100	
cM capacity (veh/h)	976	1082			1620	
Direction, Lane #	WB 1	NB 1	SB 1			
Volume Total	11	10	1			
Volume Left	11	0	0			
Volume Right	0	10	0			
cSH	976	1700	1620			
Volume to Capacity	0.01	0.01	0.00			
Queue Length 95th (m)	0.3	0.0	0.0			
Control Delay (s)	8.7	0.0	0.0			
Lane LOS	A					
Approach Delay (s)	8.7	0.0	0.0			
Approach LOS	A					
Intersection Summary						
Average Delay			4.4			
Intersection Capacity Utilization			13.7%		ICU Level of Service	A
Analysis Period (min)			15			

Lanes, Volumes, Timings

3: Queen Street S/Queen Street N & Britannia Road W

01-17-2023

Lane Group	EBL	EBT	EBR	WBL	WBT	WBR	NBL	NBT	NBR	SBL	SBT	SBR
Lane Configurations												
Traffic Volume (vph)	199	1371	115	100	706	198	96	387	85	129	286	139
Future Volume (vph)	199	1371	115	100	706	198	96	387	85	129	286	139
Ideal Flow (vphpl)	1900	1900	1900	1900	1900	1900	1900	1900	1900	1900	1900	1900
Lane Width (m)	3.5	3.5	3.5	3.5	3.5	3.5	3.5	3.5	3.5	3.5	3.5	3.5
Grade (%)		0%			0%			0%			0%	
Storage Length (m)	130.0		0.0	60.0		40.0	40.0		0.0	65.0		65.0
Storage Lanes	1		0	1		1	1		0	1		1
Taper Length (m)	7.5			7.5			7.5			7.5		
Satd. Flow (prot)	1733	3379	0	1716	3336	1483	1594	3395	0	1668	1807	1511
Flt Permitted	0.290			0.061			0.218			0.188		
Satd. Flow (perm)	527	3379	0	110	3336	1440	363	3395	0	329	1807	1470
Right Turn on Red			Yes			Yes			Yes			Yes
Satd. Flow (RTOR)		7				125		18				146
Link Speed (k/h)		50			50			40				40
Link Distance (m)		284.8			253.5			169.0				136.3
Travel Time (s)		20.5			18.3			15.2				12.3
Confl. Peds. (#/hr)	10		6	6		10	10		7	7		10
Confl. Bikes (#/hr)												
Peak Hour Factor	0.95	0.95	0.95	0.95	0.95	0.95	0.95	0.95	0.95	0.95	0.95	0.95
Growth Factor	100%	100%	100%	100%	100%	100%	100%	100%	100%	100%	100%	100%
Heavy Vehicles (%)	3%	4%	5%	4%	7%	6%	12%	1%	6%	7%	4%	4%
Bus Blockages (#/hr)	0	0	4	0	0	4	0	0	4	0	0	4
Parking (#/hr)												
Mid-Block Traffic (%)		0%			0%			0%			0%	
Adj. Flow (vph)	209	1443	121	105	743	208	101	407	89	136	301	146
Shared Lane Traffic (%)												
Lane Group Flow (vph)	209	1564	0	105	743	208	101	496	0	136	301	146
Enter Blocked Intersection	No	No	No	No	No	No	No	No	No	No	No	No
Lane Alignment	Left	Left	Right	Left	Left	Right	Left	Left	Right	Left	Left	Right
Median Width(m)		3.5			3.5			3.5			3.5	
Link Offset(m)		0.0			0.0			0.0			0.0	
Crosswalk Width(m)		4.8			4.8			4.8			4.8	
Two way Left Turn Lane												
Headway Factor	1.01	1.01	1.01	1.01	1.01	1.04	1.01	1.01	1.01	1.01	1.01	1.04
Turning Speed (k/h)	25		15	25		15	25		15	25		15
Turn Type	pm+pt	NA		pm+pt	NA	Perm	pm+pt	NA		pm+pt	NA	Perm
Protected Phases	5	2		1	6		7	4		3	8	
Permitted Phases	2			6		6	4			8		8
Detector Phase	5	2		1	6	6	7	4		3	8	8
Switch Phase												
Minimum Initial (s)	8.0	12.0		8.0	12.0	12.0	8.0	12.0		8.0	12.0	12.0
Minimum Split (s)	11.0	35.1		11.0	35.1	35.1	11.0	38.9		11.0	38.9	38.9
Total Split (s)	13.0	76.0		11.0	74.0	74.0	11.0	60.0		13.0	62.0	62.0
Total Split (%)	8.1%	47.5%		6.9%	46.3%	46.3%	6.9%	37.5%		8.1%	38.8%	38.8%
Maximum Green (s)	10.0	68.9		8.0	66.9	66.9	8.0	52.1		10.0	54.1	54.1
Yellow Time (s)	3.0	4.0		3.0	4.0	4.0	3.0	4.0		3.0	4.0	4.0
All-Red Time (s)	0.0	3.1		0.0	3.1	3.1	0.0	3.9		0.0	3.9	3.9
Lost Time Adjust (s)	-1.0	-5.0		-1.0	-5.0	-1.0	-1.0	-5.0		-1.0	-5.0	-1.0

Lanes, Volumes, Timings

3: Queen Street S/Queen Street N & Britannia Road W

01-17-2023

Lane Group	EBL	EBT	EBR	WBL	WBT	WBR	NBL	NBT	NBR	SBL	SBT	SBR
Lane Configurations												
Traffic Volume (vph)	117	858	133	116	1380	101	173	364	132	197	337	176
Future Volume (vph)	117	858	133	116	1380	101	173	364	132	197	337	176
Ideal Flow (vphpl)	1900	1900	1900	1900	1900	1900	1900	1900	1900	1900	1900	1900
Lane Width (m)	3.5	3.5	3.5	3.5	3.5	3.5	3.5	3.5	3.5	3.5	3.5	3.5
Grade (%)		0%			0%			0%			0%	
Storage Length (m)	130.0		0.0	60.0		40.0	40.0		0.0	65.0		65.0
Storage Lanes	1		0	1		1	1		0	1		1
Taper Length (m)	7.5			7.5			7.5			7.5		
Satd. Flow (prot)	1733	3387	0	1785	3500	1541	1750	3311	0	1750	1860	1541
Flt Permitted	0.055			0.172			0.177			0.194		
Satd. Flow (perm)	100	3387	0	323	3500	1489	323	3311	0	352	1860	1496
Right Turn on Red			Yes			Yes			Yes			Yes
Satd. Flow (RTOR)		14				74		35				137
Link Speed (k/h)		50			50			40				40
Link Distance (m)		284.8			253.5			169.0				136.3
Travel Time (s)		20.5			18.3			15.2				12.3
Confl. Peds. (#/hr)	13		11	11		13	11		28	28		11
Confl. Bikes (#/hr)												
Peak Hour Factor	0.94	0.94	0.94	0.94	0.94	0.94	0.94	0.94	0.94	0.94	0.94	0.94
Growth Factor	100%	100%	100%	100%	100%	100%	100%	100%	100%	100%	100%	100%
Heavy Vehicles (%)	3%	3%	0%	0%	2%	2%	2%	2%	2%	2%	1%	2%
Bus Blockages (#/hr)	0	0	4	0	0	4	0	0	4	0	0	4
Parking (#/hr)												
Mid-Block Traffic (%)		0%			0%			0%			0%	
Adj. Flow (vph)	124	913	141	123	1468	107	184	387	140	210	359	187
Shared Lane Traffic (%)												
Lane Group Flow (vph)	124	1054	0	123	1468	107	184	527	0	210	359	187
Enter Blocked Intersection	No	No	No	No	No	No	No	No	No	No	No	No
Lane Alignment	Left	Left	Right	Left	Left	Right	Left	Left	Right	Left	Left	Right
Median Width(m)		3.5			3.5			3.5			3.5	
Link Offset(m)		0.0			0.0			0.0			0.0	
Crosswalk Width(m)		4.8			4.8			4.8			4.8	
Two way Left Turn Lane												
Headway Factor	1.01	1.01	1.01	1.01	1.01	1.04	1.01	1.01	1.01	1.01	1.01	1.04
Turning Speed (k/h)	25		15	25		15	25		15	25		15
Turn Type	pm+pt	NA		pm+pt	NA	Perm	pm+pt	NA		pm+pt	NA	Perm
Protected Phases	5	2		1	6		7	4		3	8	
Permitted Phases	2			6		6	4			8		8
Detector Phase	5	2		1	6	6	7	4		3	8	8
Switch Phase												
Minimum Initial (s)	8.0	12.0		8.0	12.0	12.0	8.0	12.0		8.0	12.0	12.0
Minimum Split (s)	11.0	35.1		11.0	35.1	35.1	11.0	38.9		11.0	38.9	38.9
Total Split (s)	13.0	74.0		11.0	72.0	72.0	14.0	58.0		17.0	61.0	61.0
Total Split (%)	8.1%	46.3%		6.9%	45.0%	45.0%	8.8%	36.3%		10.6%	38.1%	38.1%
Maximum Green (s)	10.0	66.9		8.0	64.9	64.9	11.0	50.1		14.0	53.1	53.1
Yellow Time (s)	3.0	4.0		3.0	4.0	4.0	3.0	4.0		3.0	4.0	4.0
All-Red Time (s)	0.0	3.1		0.0	3.1	3.1	0.0	3.9		0.0	3.9	3.9
Lost Time Adjust (s)	-1.0	-5.0		-1.0	-5.0	-1.0	-1.0	-5.0		-1.0	-5.0	-1.0

Lanes, Volumes, Timings

3: Queen Street S/Queen Street N & Britannia Road W

01-17-2023



Lane Group	EBL	EBT	EBR	WBL	WBT	WBR	NBL	NBT	NBR	SBL	SBT	SBR
Total Lost Time (s)	2.0	2.1		2.0	2.1	6.1	2.0	2.9		2.0	2.9	6.9
Lead/Lag	Lead	Lag		Lead	Lag	Lag	Lead	Lag		Lead	Lag	Lag
Lead-Lag Optimize?	Yes	Yes		Yes	Yes	Yes	Yes	Yes		Yes	Yes	Yes
Vehicle Extension (s)	3.0	3.0		3.0	3.0	3.0	3.0	3.0		3.0	3.0	3.0
Minimum Gap (s)	3.0	3.0		3.0	3.0	3.0	3.0	3.0		3.0	3.0	3.0
Time Before Reduce (s)	0.0	0.0		0.0	0.0	0.0	0.0	0.0		0.0	0.0	0.0
Time To Reduce (s)	0.0	0.0		0.0	0.0	0.0	0.0	0.0		0.0	0.0	0.0
Recall Mode	None	C-Max		None	Max	Max	None	None		None	None	None
Walk Time (s)		8.0			8.0	8.0		9.0			9.0	9.0
Flash Dont Walk (s)		20.0			20.0	20.0		22.0			22.0	22.0
Pedestrian Calls (#/hr)		0			0	0		0			0	0
Act Effct Green (s)	98.6	85.8		95.7	84.2	80.2	51.7	38.8		56.7	41.8	37.8
Actuated g/C Ratio	0.62	0.54		0.60	0.53	0.50	0.32	0.24		0.35	0.26	0.24
v/c Ratio	0.64	0.58		0.42	0.80	0.14	0.87	0.64		0.82	0.74	0.41
Control Delay	43.8	27.6		18.1	36.5	9.8	74.5	53.4		62.9	63.0	16.5
Queue Delay	0.0	0.0		0.0	0.0	0.0	0.0	0.0		0.0	0.0	0.0
Total Delay	43.8	27.6		18.1	36.5	9.8	74.5	53.4		62.9	63.0	16.5
LOS	D	C		B	D	A	E	D		E	E	B
Approach Delay		29.3			33.5			58.8			51.5	
Approach LOS		C			C			E			D	
Queue Length 50th (m)	21.2	119.4		16.1	205.9	5.5	44.5	78.5		51.6	110.9	13.4
Queue Length 95th (m)	47.0	170.4		30.5	#301.3	19.9	#64.8	90.8		#72.7	137.0	34.4
Internal Link Dist (m)		260.8			229.5			145.0			112.3	
Turn Bay Length (m)	130.0			60.0		40.0	40.0			65.0		65.0
Base Capacity (vph)	199	1823		296	1842	783	211	1163		255	675	596
Starvation Cap Reductn	0	0		0	0	0	0	0		0	0	0
Spillback Cap Reductn	0	0		0	0	0	0	0		0	0	0
Storage Cap Reductn	0	0		0	0	0	0	0		0	0	0
Reduced v/c Ratio	0.62	0.58		0.42	0.80	0.14	0.87	0.45		0.82	0.53	0.31

Intersection Summary

Area Type: Other
 Cycle Length: 160
 Actuated Cycle Length: 160
 Offset: 114 (71%), Referenced to phase 2:EBTL, Start of Green
 Natural Cycle: 110
 Control Type: Actuated-Coordinated
 Maximum v/c Ratio: 0.87
 Intersection Signal Delay: 39.6
 Intersection LOS: D
 Intersection Capacity Utilization 90.6%
 ICU Level of Service E
 Analysis Period (min) 15
 # 95th percentile volume exceeds capacity, queue may be longer.
 Queue shown is maximum after two cycles.

Splits and Phases: 3: Queen Street S/Queen Street N & Britannia Road W

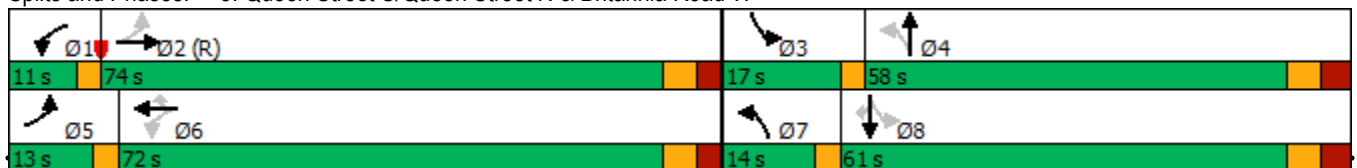

HCM Unsignalized Intersection Capacity Analysis
 6: Queen Street S & Private Access/Ellen Street

01-17-2023



Movement	EBL	EBT	EBR	WBL	WBT	WBR	NBL	NBT	NBR	SBL	SBT	SBR
Lane Configurations		↕			↕			↕			↕	
Traffic Volume (veh/h)	7	0	1	28	0	15	1	637	24	6	565	8
Future Volume (Veh/h)	7	0	1	28	0	15	1	637	24	6	565	8
Sign Control		Stop			Stop			Free			Free	
Grade		0%			0%			0%			0%	
Peak Hour Factor	0.92	0.92	0.92	0.92	0.92	0.92	0.92	0.92	0.92	0.92	0.92	0.92
Hourly flow rate (vph)	8	0	1	30	0	16	1	692	26	7	614	9
Pedestrians		8			9			3				
Lane Width (m)		3.5			3.5			3.5				
Walking Speed (m/s)		1.2			1.2			1.2				
Percent Blockage		1			1			0				
Right turn flare (veh)												
Median type								None			None	
Median storage veh												
Upstream signal (m)												331
pX, platoon unblocked	0.82	0.82	0.82	0.82	0.82		0.82					
vC, conflicting volume	1364	1370	630	1352	1361	714	631			727		
vC1, stage 1 conf vol												
vC2, stage 2 conf vol												
vCu, unblocked vol	1334	1342	443	1321	1331	714	445			727		
tC, single (s)	7.2	6.5	6.2	7.1	6.5	6.2	5.1			4.1		
tC, 2 stage (s)												
tF (s)	3.6	4.0	3.3	3.5	4.0	3.3	3.1			2.2		
p0 queue free %	92	100	100	72	100	96	100			99		
cM capacity (veh/h)	95	124	505	108	125	431	609			879		
Direction, Lane #	EB 1	WB 1	NB 1	SB 1								
Volume Total	9	46	719	630								
Volume Left	8	30	1	7								
Volume Right	1	16	26	9								
cSH	105	146	609	879								
Volume to Capacity	0.09	0.32	0.00	0.01								
Queue Length 95th (m)	2.2	10.0	0.0	0.2								
Control Delay (s)	42.5	40.6	0.0	0.2								
Lane LOS	E	E	A	A								
Approach Delay (s)	42.5	40.6	0.0	0.2								
Approach LOS	E	E										
Intersection Summary												
Average Delay			1.7									
Intersection Capacity Utilization			46.6%		ICU Level of Service					A		
Analysis Period (min)			15									

HCM Unsignalized Intersection Capacity Analysis

9: Queen Street S & James Street

01-17-2023



Movement	EBL	EBR	NBL	NBT	SBT	SBR
Lane Configurations						
Traffic Volume (veh/h)	7	2	4	655	577	9
Future Volume (Veh/h)	7	2	4	655	577	9
Sign Control	Stop			Free	Free	
Grade	0%			0%	0%	
Peak Hour Factor	0.93	0.93	0.93	0.93	0.93	0.93
Hourly flow rate (vph)	8	2	4	704	620	10
Pedestrians	6					
Lane Width (m)	3.5					
Walking Speed (m/s)	1.2					
Percent Blockage	0					
Right turn flare (veh)						
Median type				None	None	
Median storage veh						
Upstream signal (m)					169	
pX, platoon unblocked	0.80	0.80	0.80			
vC, conflicting volume	1343	631	636			
vC1, stage 1 conf vol						
vC2, stage 2 conf vol						
vCu, unblocked vol	1304	415	421			
tC, single (s)	6.4	6.2	4.1			
tC, 2 stage (s)						
tF (s)	3.5	3.3	2.2			
p0 queue free %	94	100	100			
cM capacity (veh/h)	142	511	916			
Direction, Lane #	EB 1	NB 1	SB 1			
Volume Total	10	708	630			
Volume Left	8	4	0			
Volume Right	2	0	10			
cSH	166	916	1700			
Volume to Capacity	0.06	0.00	0.37			
Queue Length 95th (m)	1.5	0.1	0.0			
Control Delay (s)	28.1	0.1	0.0			
Lane LOS	D	A				
Approach Delay (s)	28.1	0.1	0.0			
Approach LOS	D					
Intersection Summary						
Average Delay			0.3			
Intersection Capacity Utilization			47.7%	ICU Level of Service	A	
Analysis Period (min)			15			

HCM Unsignalized Intersection Capacity Analysis

10: William Street & James Street

01-17-2023



Movement	WBL	WBR	NBT	NBR	SBL	SBT
Lane Configurations						
Traffic Volume (veh/h)	13	0	1	9	0	0
Future Volume (Veh/h)	13	0	1	9	0	0
Sign Control	Stop		Free		Free	
Grade	0%		0%		0%	
Peak Hour Factor	0.92	0.92	0.92	0.92	0.92	0.92
Hourly flow rate (vph)	14	0	1	10	0	0
Pedestrians						
Lane Width (m)						
Walking Speed (m/s)						
Percent Blockage						
Right turn flare (veh)						
Median type	None			None		
Median storage veh						
Upstream signal (m)						
pX, platoon unblocked						
vC, conflicting volume	6	6			11	
vC1, stage 1 conf vol						
vC2, stage 2 conf vol						
vCu, unblocked vol	6	6			11	
tC, single (s)	6.4	6.2			4.1	
tC, 2 stage (s)						
tF (s)	3.5	3.3			2.2	
p0 queue free %	99	100			100	
cM capacity (veh/h)	1021	1083			1621	
Direction, Lane #	WB 1	NB 1	SB 1			
Volume Total	14	11	0			
Volume Left	14	0	0			
Volume Right	0	10	0			
cSH	1021	1700	1700			
Volume to Capacity	0.01	0.01	0.00			
Queue Length 95th (m)	0.3	0.0	0.0			
Control Delay (s)	8.6	0.0	0.0			
Lane LOS	A					
Approach Delay (s)	8.6	0.0	0.0			
Approach LOS	A					
Intersection Summary						
Average Delay			4.8			
Intersection Capacity Utilization			13.3%	ICU Level of Service	A	
Analysis Period (min)			15			

Lanes, Volumes, Timings

3: Queen Street S/Queen Street N & Britannia Road W

01-17-2023

Lane Group	EBL	EBT	EBR	WBL	WBT	WBR	NBL	NBT	NBR	SBL	SBT	SBR
Lane Configurations												
Traffic Volume (vph)	117	858	133	116	1380	101	173	364	132	197	337	176
Future Volume (vph)	117	858	133	116	1380	101	173	364	132	197	337	176
Ideal Flow (vphpl)	1900	1900	1900	1900	1900	1900	1900	1900	1900	1900	1900	1900
Lane Width (m)	3.5	3.5	3.5	3.5	3.5	3.5	3.5	3.5	3.5	3.5	3.5	3.5
Grade (%)		0%			0%			0%			0%	
Storage Length (m)	130.0		0.0	60.0		40.0	40.0		0.0	65.0		65.0
Storage Lanes	1		0	1		1	1		0	1		1
Taper Length (m)	7.5			7.5			7.5			7.5		
Satd. Flow (prot)	1733	3387	0	1785	3500	1541	1750	3311	0	1750	1860	1541
Flt Permitted	0.053			0.152			0.152			0.293		
Satd. Flow (perm)	97	3387	0	286	3500	1489	278	3311	0	530	1860	1496
Right Turn on Red			Yes			Yes			Yes			Yes
Satd. Flow (RTOR)		13				95		38				159
Link Speed (k/h)		50			50			40				40
Link Distance (m)		284.8			253.5			169.0				136.3
Travel Time (s)		20.5			18.3			15.2				12.3
Confl. Peds. (#/hr)	13		11	11		13	11		28	28		11
Confl. Bikes (#/hr)												
Peak Hour Factor	0.94	0.94	0.94	0.94	0.94	0.94	0.94	0.94	0.94	0.94	0.94	0.94
Growth Factor	100%	100%	100%	100%	100%	100%	100%	100%	100%	100%	100%	100%
Heavy Vehicles (%)	3%	3%	0%	0%	2%	2%	2%	2%	2%	2%	1%	2%
Bus Blockages (#/hr)	0	0	4	0	0	4	0	0	4	0	0	4
Parking (#/hr)												
Mid-Block Traffic (%)		0%			0%			0%			0%	
Adj. Flow (vph)	124	913	141	123	1468	107	184	387	140	210	359	187
Shared Lane Traffic (%)												
Lane Group Flow (vph)	124	1054	0	123	1468	107	184	527	0	210	359	187
Enter Blocked Intersection	No	No	No	No	No	No	No	No	No	No	No	No
Lane Alignment	Left	Left	Right	Left	Left	Right	Left	Left	Right	Left	Left	Right
Median Width(m)		3.5			3.5			3.5			3.5	
Link Offset(m)		0.0			0.0			0.0			0.0	
Crosswalk Width(m)		4.8			4.8			4.8			4.8	
Two way Left Turn Lane												
Headway Factor	1.01	1.01	1.01	1.01	1.01	1.04	1.01	1.01	1.01	1.01	1.01	1.04
Turning Speed (k/h)	25		15	25		15	25		15	25		15
Turn Type	pm+pt	NA		pm+pt	NA	Perm	pm+pt	NA		pm+pt	NA	Perm
Protected Phases	5	2		1	6		7	4		3	8	
Permitted Phases	2			6		6	4			8		8
Detector Phase	5	2		1	6	6	7	4		3	8	8
Switch Phase												
Minimum Initial (s)	8.0	12.0		8.0	12.0	12.0	8.0	12.0		8.0	12.0	12.0
Minimum Split (s)	11.0	35.1		11.0	35.1	35.1	11.0	38.9		11.0	38.9	38.9
Total Split (s)	11.0	67.0		11.0	67.0	67.0	23.0	66.0		16.0	59.0	59.0
Total Split (%)	6.9%	41.9%		6.9%	41.9%	41.9%	14.4%	41.3%		10.0%	36.9%	36.9%
Maximum Green (s)	8.0	59.9		8.0	59.9	59.9	20.0	58.1		13.0	51.1	51.1
Yellow Time (s)	3.0	4.0		3.0	4.0	4.0	3.0	4.0		3.0	4.0	4.0
All-Red Time (s)	0.0	3.1		0.0	3.1	3.1	0.0	3.9		0.0	3.9	3.9
Lost Time Adjust (s)	-1.0	-5.0		-1.0	-5.0	-1.0	-1.0	-5.0		-1.0	-5.0	-1.0

Lanes, Volumes, Timings

3: Queen Street S/Queen Street N & Britannia Road W

01-17-2023



Lane Group	EBL	EBT	EBR	WBL	WBT	WBR	NBL	NBT	NBR	SBL	SBT	SBR
Total Lost Time (s)	2.0	2.1		2.0	2.1	6.1	2.0	2.9		2.0	2.9	6.9
Lead/Lag	Lead	Lag		Lead	Lag	Lag	Lead	Lag		Lead	Lag	Lag
Lead-Lag Optimize?	Yes	Yes		Yes	Yes	Yes	Yes	Yes		Yes	Yes	Yes
Vehicle Extension (s)	3.0	3.0		3.0	3.0	3.0	3.0	3.0		3.0	3.0	3.0
Minimum Gap (s)	3.0	3.0		3.0	3.0	3.0	3.0	3.0		3.0	3.0	3.0
Time Before Reduce (s)	0.0	0.0		0.0	0.0	0.0	0.0	0.0		0.0	0.0	0.0
Time To Reduce (s)	0.0	0.0		0.0	0.0	0.0	0.0	0.0		0.0	0.0	0.0
Recall Mode	None	C-Max		None	Max	Max	None	None		None	None	None
Walk Time (s)		8.0			8.0	8.0		9.0			9.0	9.0
Flash Dont Walk (s)		20.0			20.0	20.0		22.0			22.0	22.0
Pedestrian Calls (#/hr)		0			0	0		0			0	0
Act Effct Green (s)	92.3	79.3		89.8	78.0	74.0	62.5	46.0		56.5	41.6	37.6
Actuated g/C Ratio	0.58	0.50		0.56	0.49	0.46	0.39	0.29		0.35	0.26	0.24
v/c Ratio	0.66	0.63		0.46	0.86	0.14	0.66	0.54		0.72	0.74	0.40
Control Delay	48.9	33.2		22.7	43.7	7.6	43.3	45.3		47.3	63.3	12.0
Queue Delay	0.0	0.0		0.0	0.0	0.0	0.0	0.0		0.0	0.0	0.0
Total Delay	48.9	33.2		22.7	43.7	7.6	43.3	45.3		47.3	63.3	12.0
LOS	D	C		C	D	A	D	D		D	E	B
Approach Delay		34.9			39.9			44.8			46.2	
Approach LOS		C			D			D			D	
Queue Length 50th (m)	23.5	134.1		18.2	230.1	2.2	41.2	72.4		47.8	111.2	7.4
Queue Length 95th (m)	#54.2	185.6		34.6	#321.2	16.1	53.4	81.9		60.8	137.3	27.8
Internal Link Dist (m)		260.8			229.5			145.0			112.3	
Turn Bay Length (m)	130.0			60.0		40.0	40.0			65.0		65.0
Base Capacity (vph)	188	1684		270	1705	739	302	1328		293	652	594
Starvation Cap Reductn	0	0		0	0	0	0	0		0	0	0
Spillback Cap Reductn	0	0		0	0	0	0	0		0	0	0
Storage Cap Reductn	0	0		0	0	0	0	0		0	0	0
Reduced v/c Ratio	0.66	0.63		0.46	0.86	0.14	0.61	0.40		0.72	0.55	0.31

Intersection Summary

Area Type: Other
 Cycle Length: 160
 Actuated Cycle Length: 160
 Offset: 114 (71%), Referenced to phase 2:EBTL, Start of Green
 Natural Cycle: 110
 Control Type: Actuated-Coordinated
 Maximum v/c Ratio: 0.86
 Intersection Signal Delay: 40.5 Intersection LOS: D
 Intersection Capacity Utilization 90.6% ICU Level of Service E
 Analysis Period (min) 15
 # 95th percentile volume exceeds capacity, queue may be longer.
 Queue shown is maximum after two cycles.

Splits and Phases: 3: Queen Street S/Queen Street N & Britannia Road W

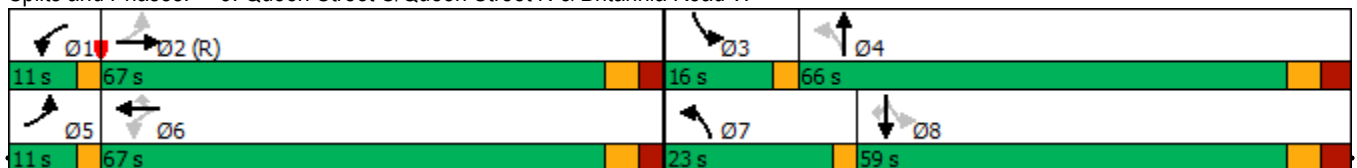

Appendix E

2016 Transportation Tomorrow Survey (TTS)

Data Analysis

Mode of Transportation - AM Peak Period

Cross Tabulation Query Form - Trip - 2016 v1.1

Row: Primary travel mode of trip - mode_prime

Column: 2006 GTA zone of household - gta06_hhld

Filters:

Primary travel mode of trip - mode_prime In B

and

2006 GTA zone of household - gta06_hhld In 3715

and

Start time of trip - start_time In 600-900

and

Type of dwelling unit - dwell_type In 1

	C	D	G	J	M	P	T	U	W
3718		3718	3836						
3		3							

Trip 2016

Table:

Mode of Transportation/Traffic Zones	3715	3718	3836	Total	Percentage
Transit excluding GO rail	102	85	10	197	4.2%
Cycle	15	0	0	15	0.3%
Auto driver	1935	1239	9	3183	68.1%
GO rail only	144	59	0	203	4.3%
Joint GO rail and local transit	84	32	10	126	2.7%
Auto passenger	235	394	0	629	13.5%
Taxi passenger	0	19	0	19	0.4%
Walk	216	85	0	301	6.4%
Total	2731	1913	29	4673	100%

Mode of Transportation - PM Peak Period

Cross Tabulation Query Form - Trip - 2016 v1.1

Row: Primary travel mode of trip - mode_prime

Column: 2006 GTA zone of household - gta06_hhld

Filters:

Primary travel mode of trip - mode_prime In B C D G J M P T U W

and

2006 GTA zone of household - gta06_hhld In 3715 3718 3836

and

Start time of trip - start_time In 1600-1900

and

Type of dwelling unit - dwell_type In 1 3

Trip 2016

Table:

Mode of Transportation/Traffic Zones	3715	3718	3836	Total	Percentage
Transit excluding GO rail	43	59	0	102	2.4%
Cycle	32	0	0	32	0.7%
Auto driver	1732	1427	39	3198	74.0%
GO rail only	123	59	0	182	4.2%
Joint GO rail and local transit	92	29	10	131	3.0%
Auto passenger	215	350	0	565	13.1%
Walk	64	45	0	109	2.5%
Total	2301	1969	49	4319	100%

Appendix F

Future Total Level of Service Calculations

Lanes, Volumes, Timings

3: Queen Street S/Queen Street N & Britannia Road W

01-17-2023

Lane Group	EBL	EBT	EBR	WBL	WBT	WBR	NBL	NBT	NBR	SBL	SBT	SBR
Lane Configurations												
Traffic Volume (vph)	199	1371	117	101	706	198	101	397	90	129	289	139
Future Volume (vph)	199	1371	117	101	706	198	101	397	90	129	289	139
Ideal Flow (vphpl)	1900	1900	1900	1900	1900	1900	1900	1900	1900	1900	1900	1900
Lane Width (m)	3.5	3.5	3.5	3.5	3.5	3.5	3.5	3.5	3.5	3.5	3.5	3.5
Grade (%)		0%			0%			0%			0%	
Storage Length (m)	130.0		0.0	60.0		40.0	40.0		0.0	65.0		65.0
Storage Lanes	1		0	1		1	1		0	1		1
Taper Length (m)	7.5			7.5			7.5			7.5		
Satd. Flow (prot)	1733	3379	0	1716	3336	1483	1594	3390	0	1668	1807	1511
Flt Permitted	0.294			0.064			0.443			0.159		
Satd. Flow (perm)	534	3379	0	116	3336	1440	736	3390	0	278	1807	1470
Right Turn on Red			Yes			Yes			Yes			Yes
Satd. Flow (RTOR)		8				135		18				146
Link Speed (k/h)		50			50			40				40
Link Distance (m)		284.8			253.5			169.0				136.3
Travel Time (s)		20.5			18.3			15.2				12.3
Confl. Peds. (#/hr)	10		6	6		10	10		7	7		10
Confl. Bikes (#/hr)												
Peak Hour Factor	0.95	0.95	0.95	0.95	0.95	0.95	0.95	0.95	0.95	0.95	0.95	0.95
Growth Factor	100%	100%	100%	100%	100%	100%	100%	100%	100%	100%	100%	100%
Heavy Vehicles (%)	3%	4%	5%	4%	7%	6%	12%	1%	6%	7%	4%	4%
Bus Blockages (#/hr)	0	0	4	0	0	4	0	0	4	0	0	4
Parking (#/hr)												
Mid-Block Traffic (%)		0%			0%			0%			0%	
Adj. Flow (vph)	209	1443	123	106	743	208	106	418	95	136	304	146
Shared Lane Traffic (%)												
Lane Group Flow (vph)	209	1566	0	106	743	208	106	513	0	136	304	146
Enter Blocked Intersection	No	No	No	No	No	No	No	No	No	No	No	No
Lane Alignment	Left	Left	Right	Left	Left	Right	Left	Left	Right	Left	Left	Right
Median Width(m)		3.5			3.5			3.5			3.5	
Link Offset(m)		0.0			0.0			0.0			0.0	
Crosswalk Width(m)		4.8			4.8			4.8			4.8	
Two way Left Turn Lane												
Headway Factor	1.01	1.01	1.01	1.01	1.01	1.04	1.01	1.01	1.01	1.01	1.01	1.04
Turning Speed (k/h)	25		15	25		15	25		15	25		15
Turn Type	pm+pt	NA		pm+pt	NA	Perm	Perm	NA		pm+pt	NA	Perm
Protected Phases	5	2		1	6			4		3	8	
Permitted Phases	2			6		6	4			8		8
Detector Phase	5	2		1	6	6	4	4		3	8	8
Switch Phase												
Minimum Initial (s)	8.0	12.0		8.0	12.0	12.0	12.0	12.0		8.0	12.0	12.0
Minimum Split (s)	11.0	35.1		11.0	35.1	35.1	38.9	38.9		11.0	38.9	38.9
Total Split (s)	13.0	83.0		11.0	81.0	81.0	53.0	53.0		13.0	66.0	66.0
Total Split (%)	8.1%	51.9%		6.9%	50.6%	50.6%	33.1%	33.1%		8.1%	41.3%	41.3%
Maximum Green (s)	10.0	75.9		8.0	73.9	73.9	45.1	45.1		10.0	58.1	58.1
Yellow Time (s)	3.0	4.0		3.0	4.0	4.0	4.0	4.0		3.0	4.0	4.0
All-Red Time (s)	0.0	3.1		0.0	3.1	3.1	3.9	3.9		0.0	3.9	3.9
Lost Time Adjust (s)	-1.0	-5.0		-1.0	-5.0	-1.0	-1.0	-5.0		-1.0	-5.0	-1.0

HCM Unsignalized Intersection Capacity Analysis
 6: Queen Street S & Private Access/Ellen Street

01-17-2023



Movement	EBL	EBT	EBR	WBL	WBT	WBR	NBL	NBT	NBR	SBL	SBT	SBR
Lane Configurations		↕			↕			↕			↕	
Traffic Volume (veh/h)	2	0	1	25	0	13	3	561	24	15	514	7
Future Volume (Veh/h)	2	0	1	25	0	13	3	561	24	15	514	7
Sign Control		Stop			Stop			Free			Free	
Grade		0%			0%			0%			0%	
Peak Hour Factor	0.95	0.95	0.95	0.95	0.95	0.95	0.95	0.95	0.95	0.95	0.95	0.95
Hourly flow rate (vph)	2	0	1	26	0	14	3	591	25	16	541	7
Pedestrians					10			1			1	
Lane Width (m)					3.5			3.5			3.5	
Walking Speed (m/s)					1.2			1.2			1.2	
Percent Blockage					1			0			0	
Right turn flare (veh)												
Median type								None			None	
Median storage veh												
Upstream signal (m)											331	
pX, platoon unblocked	0.87	0.87	0.87	0.87	0.87		0.87					
vC, conflicting volume	1201	1208	546	1198	1200	614	548			626		
vC1, stage 1 conf vol												
vC2, stage 2 conf vol												
vCu, unblocked vol	1156	1165	403	1153	1155	614	406			626		
tC, single (s)	7.6	6.5	6.2	7.1	6.5	6.3	4.4			4.2		
tC, 2 stage (s)												
tF (s)	4.0	4.0	3.3	3.5	4.0	3.4	2.5			2.3		
p0 queue free %	98	100	100	82	100	97	100			98		
cM capacity (veh/h)	116	166	567	148	168	476	873			924		
Direction, Lane #	EB 1	WB 1	NB 1	SB 1								
Volume Total	3	40	619	564								
Volume Left	2	26	3	16								
Volume Right	1	14	25	7								
cSH	157	195	873	924								
Volume to Capacity	0.02	0.20	0.00	0.02								
Queue Length 95th (m)	0.5	6.0	0.1	0.4								
Control Delay (s)	28.3	28.1	0.1	0.5								
Lane LOS	D	D	A	A								
Approach Delay (s)	28.3	28.1	0.1	0.5								
Approach LOS	D	D										
Intersection Summary												
Average Delay			1.3									
Intersection Capacity Utilization			48.3%		ICU Level of Service				A			
Analysis Period (min)			15									

HCM Unsignalized Intersection Capacity Analysis

9: Queen Street S & James Street

01-17-2023



Movement	EBL	EBR	NBL	NBT	SBT	SBR
Lane Configurations						
Traffic Volume (veh/h)	27	42	15	559	494	13
Future Volume (Veh/h)	27	42	15	559	494	13
Sign Control	Stop			Free	Free	
Grade	0%			0%	0%	
Peak Hour Factor	0.93	0.93	0.93	0.93	0.93	0.93
Hourly flow rate (vph)	29	45	16	601	531	14
Pedestrians	4					
Lane Width (m)	3.5					
Walking Speed (m/s)	1.2					
Percent Blockage	0					
Right turn flare (veh)						
Median type				None	None	
Median storage veh						
Upstream signal (m)					169	
pX, platoon unblocked	0.85	0.85	0.85			
vC, conflicting volume	1175	542	549			
vC1, stage 1 conf vol						
vC2, stage 2 conf vol						
vCu, unblocked vol	1119	377	385			
tC, single (s)	6.5	6.2	4.1			
tC, 2 stage (s)						
tF (s)	3.6	3.3	2.2			
p0 queue free %	84	92	98			
cM capacity (veh/h)	181	573	1007			
Direction, Lane #	EB 1	NB 1	SB 1			
Volume Total	74	617	545			
Volume Left	29	16	0			
Volume Right	45	0	14			
cSH	310	1007	1700			
Volume to Capacity	0.24	0.02	0.32			
Queue Length 95th (m)	7.3	0.4	0.0			
Control Delay (s)	20.2	0.4	0.0			
Lane LOS	C	A				
Approach Delay (s)	20.2	0.4	0.0			
Approach LOS	C					
Intersection Summary						
Average Delay			1.4			
Intersection Capacity Utilization			52.2%	ICU Level of Service	A	
Analysis Period (min)			15			

HCM Unsignalized Intersection Capacity Analysis

10: William Street & James Street

01-17-2023



Movement	WBL	WBR	NBT	NBR	SBL	SBT
Lane Configurations						
Traffic Volume (veh/h)	19	0	0	12	0	0
Future Volume (Veh/h)	19	0	0	12	0	0
Sign Control	Stop		Free		Free	
Grade	0%		0%		0%	
Peak Hour Factor	0.88	0.88	0.88	0.88	0.88	0.88
Hourly flow rate (vph)	22	0	0	14	0	0
Pedestrians	1					
Lane Width (m)	3.5					
Walking Speed (m/s)	1.2					
Percent Blockage	0					
Right turn flare (veh)						
Median type	None			None		
Median storage veh						
Upstream signal (m)						
pX, platoon unblocked						
vC, conflicting volume	1	1			15	
vC1, stage 1 conf vol						
vC2, stage 2 conf vol						
vCu, unblocked vol	1	1			15	
tC, single (s)	6.6	6.2			4.1	
tC, 2 stage (s)						
tF (s)	3.7	3.3			2.2	
p0 queue free %	98	100			100	
cM capacity (veh/h)	983	1089			1615	
Direction, Lane #	WB 1	NB 1	SB 1			
Volume Total	22	14	0			
Volume Left	22	0	0			
Volume Right	0	14	0			
cSH	983	1700	1700			
Volume to Capacity	0.02	0.01	0.00			
Queue Length 95th (m)	0.5	0.0	0.0			
Control Delay (s)	8.7	0.0	0.0			
Lane LOS	A					
Approach Delay (s)	8.7	0.0	0.0			
Approach LOS	A					
Intersection Summary						
Average Delay			5.3			
Intersection Capacity Utilization			13.7%	ICU Level of Service	A	
Analysis Period (min)			15			

HCM Unsignalized Intersection Capacity Analysis

13: James Street & Site Access

01-17-2023



Movement	EBL	EBT	WBT	WBR	SBL	SBR
Lane Configurations						
Traffic Volume (veh/h)	3	9	10	18	40	9
Future Volume (Veh/h)	3	9	10	18	40	9
Sign Control		Free	Free		Stop	
Grade		0%	0%		0%	
Peak Hour Factor	0.92	0.92	0.92	0.92	0.92	0.92
Hourly flow rate (vph)	3	10	11	20	43	10
Pedestrians		20	20		20	
Lane Width (m)		3.5	3.5		3.5	
Walking Speed (m/s)		1.2	1.2		1.2	
Percent Blockage		2	2		2	
Right turn flare (veh)						
Median type		None	None			
Median storage (veh)						
Upstream signal (m)						
pX, platoon unblocked						
vC, conflicting volume	51				77	61
vC1, stage 1 conf vol						
vC2, stage 2 conf vol						
vCu, unblocked vol	51				77	61
tC, single (s)	4.1				6.4	6.2
tC, 2 stage (s)						
tF (s)	2.2				3.5	3.3
p0 queue free %	100				95	99
cM capacity (veh/h)	1530				894	972
Direction, Lane #	EB 1	WB 1	SB 1			
Volume Total	13	31	53			
Volume Left	3	0	43			
Volume Right	0	20	10			
cSH	1530	1700	908			
Volume to Capacity	0.00	0.02	0.06			
Queue Length 95th (m)	0.0	0.0	1.5			
Control Delay (s)	1.7	0.0	9.2			
Lane LOS	A		A			
Approach Delay (s)	1.7	0.0	9.2			
Approach LOS			A			
Intersection Summary						
Average Delay			5.3			
Intersection Capacity Utilization			23.1%	ICU Level of Service		A
Analysis Period (min)			15			

Lanes, Volumes, Timings

3: Queen Street S/Queen Street N & Britannia Road W

01-17-2023

Lane Group	EBL	EBT	EBR	WBL	WBT	WBR	NBL	NBT	NBR	SBL	SBT	SBR
Lane Configurations												
Traffic Volume (vph)	199	1371	117	101	706	198	101	397	90	129	289	139
Future Volume (vph)	199	1371	117	101	706	198	101	397	90	129	289	139
Ideal Flow (vphpl)	1900	1900	1900	1900	1900	1900	1900	1900	1900	1900	1900	1900
Lane Width (m)	3.5	3.5	3.5	3.5	3.5	3.5	3.5	3.5	3.5	3.5	3.5	3.5
Grade (%)		0%			0%			0%			0%	
Storage Length (m)	130.0		0.0	60.0		40.0	40.0		0.0	65.0		65.0
Storage Lanes	1		0	1		1	1		0	1		1
Taper Length (m)	7.5			7.5			7.5			7.5		
Satd. Flow (prot)	1733	3379	0	1716	3336	1483	1594	3390	0	1668	1807	1511
Flt Permitted	0.289			0.060			0.218			0.177		
Satd. Flow (perm)	525	3379	0	108	3336	1440	363	3390	0	310	1807	1470
Right Turn on Red			Yes			Yes			Yes			Yes
Satd. Flow (RTOR)		7				125		19				146
Link Speed (k/h)		50			50			40				40
Link Distance (m)		284.8			253.5			169.0				136.3
Travel Time (s)		20.5			18.3			15.2				12.3
Confl. Peds. (#/hr)	10		6	6		10	10		7	7		10
Confl. Bikes (#/hr)												
Peak Hour Factor	0.95	0.95	0.95	0.95	0.95	0.95	0.95	0.95	0.95	0.95	0.95	0.95
Growth Factor	100%	100%	100%	100%	100%	100%	100%	100%	100%	100%	100%	100%
Heavy Vehicles (%)	3%	4%	5%	4%	7%	6%	12%	1%	6%	7%	4%	4%
Bus Blockages (#/hr)	0	0	4	0	0	4	0	0	4	0	0	4
Parking (#/hr)												
Mid-Block Traffic (%)		0%			0%			0%			0%	
Adj. Flow (vph)	209	1443	123	106	743	208	106	418	95	136	304	146
Shared Lane Traffic (%)												
Lane Group Flow (vph)	209	1566	0	106	743	208	106	513	0	136	304	146
Enter Blocked Intersection	No	No	No	No	No	No	No	No	No	No	No	No
Lane Alignment	Left	Left	Right	Left	Left	Right	Left	Left	Right	Left	Left	Right
Median Width(m)		3.5			3.5			3.5			3.5	
Link Offset(m)		0.0			0.0			0.0			0.0	
Crosswalk Width(m)		4.8			4.8			4.8			4.8	
Two way Left Turn Lane												
Headway Factor	1.01	1.01	1.01	1.01	1.01	1.04	1.01	1.01	1.01	1.01	1.01	1.04
Turning Speed (k/h)	25		15	25		15	25		15	25		15
Turn Type	pm+pt	NA		pm+pt	NA	Perm	pm+pt	NA		pm+pt	NA	Perm
Protected Phases	5	2		1	6		7	4		3	8	
Permitted Phases	2			6		6	4			8		8
Detector Phase	5	2		1	6	6	7	4		3	8	8
Switch Phase												
Minimum Initial (s)	8.0	12.0		8.0	12.0	12.0	6.5	12.0		8.0	12.0	12.0
Minimum Split (s)	11.0	35.1		11.0	35.1	35.1	11.0	38.9		11.0	38.9	38.9
Total Split (s)	13.0	76.0		11.0	74.0	74.0	11.0	60.0		13.0	62.0	62.0
Total Split (%)	8.1%	47.5%		6.9%	46.3%	46.3%	6.9%	37.5%		8.1%	38.8%	38.8%
Maximum Green (s)	10.0	68.9		8.0	66.9	66.9	8.0	52.1		10.0	54.1	54.1
Yellow Time (s)	3.0	4.0		3.0	4.0	4.0	3.0	4.0		3.0	4.0	4.0
All-Red Time (s)	0.0	3.1		0.0	3.1	3.1	0.0	3.9		0.0	3.9	3.9
Lost Time Adjust (s)	-1.0	-5.0		-1.0	-5.0	-1.0	-1.0	-5.0		-1.0	-5.0	-1.0

Lanes, Volumes, Timings

3: Queen Street S/Queen Street N & Britannia Road W

01-17-2023

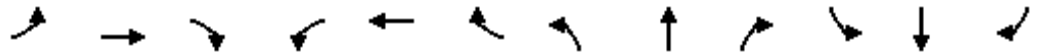

Lane Group	EBL	EBT	EBR	WBL	WBT	WBR	NBL	NBT	NBR	SBL	SBT	SBR
Total Lost Time (s)	2.0	2.1		2.0	2.1	6.1	2.0	2.9		2.0	2.9	6.9
Lead/Lag	Lead	Lag		Lead	Lag	Lag	Lead	Lag		Lead	Lag	Lag
Lead-Lag Optimize?	Yes	Yes		Yes	Yes	Yes	Yes	Yes		Yes	Yes	Yes
Vehicle Extension (s)	3.0	3.0		3.0	3.0	3.0	3.0	3.0		3.0	3.0	3.0
Minimum Gap (s)	3.0	3.0		3.0	3.0	3.0	3.0	3.0		3.0	3.0	3.0
Time Before Reduce (s)	0.0	0.0		0.0	0.0	0.0	0.0	0.0		0.0	0.0	0.0
Time To Reduce (s)	0.0	0.0		0.0	0.0	0.0	0.0	0.0		0.0	0.0	0.0
Recall Mode	None	C-Max		None	Max	Max	None	None		None	None	None
Walk Time (s)		8.0			8.0	8.0		9.0			9.0	9.0
Flash Dont Walk (s)		20.0			20.0	20.0		22.0			22.0	22.0
Pedestrian Calls (#/hr)		0			0	0		0			0	0
Act Effct Green (s)	105.7	91.4		102.5	89.8	85.8	45.9	36.0		49.9	38.0	34.0
Actuated g/C Ratio	0.66	0.57		0.64	0.56	0.54	0.29	0.22		0.31	0.24	0.21
v/c Ratio	0.46	0.81		0.54	0.40	0.25	0.61	0.66		0.72	0.71	0.34
Control Delay	14.7	32.9		32.3	22.0	10.0	55.4	57.9		61.9	64.8	8.7
Queue Delay	0.0	0.0		0.0	0.0	0.0	0.0	0.0		0.0	0.0	0.0
Total Delay	14.7	32.9		32.3	22.0	10.0	55.4	57.9		61.9	64.8	8.7
LOS	B	C		C	C	A	E	E		E	E	A
Approach Delay		30.7			20.7			57.5			50.1	
Approach LOS		C			C			E			D	
Queue Length 50th (m)	25.2	210.7		12.4	71.1	13.2	26.3	80.3		34.3	94.4	0.0
Queue Length 95th (m)	44.2	#316.3		36.2	106.6	35.6	39.4	93.6		49.0	120.4	18.1
Internal Link Dist (m)		260.8			229.5			145.0			112.3	
Turn Bay Length (m)	130.0			60.0		40.0	40.0			65.0		65.0
Base Capacity (vph)	456	1933		195	1871	829	173	1222		189	667	601
Starvation Cap Reductn	0	0		0	0	0	0	0		0	0	0
Spillback Cap Reductn	0	0		0	0	0	0	0		0	0	0
Storage Cap Reductn	0	0		0	0	0	0	0		0	0	0
Reduced v/c Ratio	0.46	0.81		0.54	0.40	0.25	0.61	0.42		0.72	0.46	0.24

Intersection Summary

Area Type: Other
 Cycle Length: 160
 Actuated Cycle Length: 160
 Offset: 2 (1%), Referenced to phase 2:EBTL, Start of Green
 Natural Cycle: 110
 Control Type: Actuated-Coordinated
 Maximum v/c Ratio: 0.81
 Intersection Signal Delay: 35.0 Intersection LOS: D
 Intersection Capacity Utilization 85.5% ICU Level of Service E
 Analysis Period (min) 15
 # 95th percentile volume exceeds capacity, queue may be longer.
 Queue shown is maximum after two cycles.

Splits and Phases: 3: Queen Street S/Queen Street N & Britannia Road W

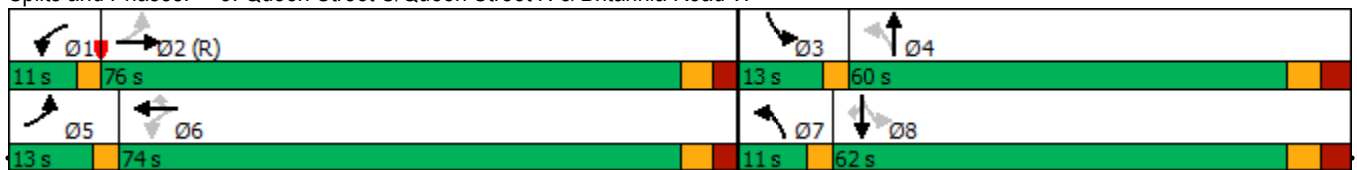

Lanes, Volumes, Timings

3: Queen Street S/Queen Street N & Britannia Road W

01-17-2023

Lane Group	EBL	EBT	EBR	WBL	WBT	WBR	NBL	NBT	NBR	SBL	SBT	SBR
Lane Configurations												
Traffic Volume (vph)	117	858	138	120	1380	101	176	369	134	197	345	176
Future Volume (vph)	117	858	138	120	1380	101	176	369	134	197	345	176
Ideal Flow (vphpl)	1900	1900	1900	1900	1900	1900	1900	1900	1900	1900	1900	1900
Lane Width (m)	3.5	3.5	3.5	3.5	3.5	3.5	3.5	3.5	3.5	3.5	3.5	3.5
Grade (%)		0%			0%			0%			0%	
Storage Length (m)	130.0		0.0	60.0		40.0	40.0		0.0	65.0		65.0
Storage Lanes	1		0	1		1	1		0	1		1
Taper Length (m)	7.5			7.5			7.5			7.5		
Satd. Flow (prot)	1733	3383	0	1785	3500	1541	1750	3311	0	1750	1860	1541
Flt Permitted	0.054			0.168			0.173			0.193		
Satd. Flow (perm)	99	3383	0	316	3500	1489	316	3311	0	350	1860	1496
Right Turn on Red			Yes			Yes			Yes			Yes
Satd. Flow (RTOR)		15				74		35				136
Link Speed (k/h)		50			50			40			40	
Link Distance (m)		284.8			253.5			169.0			136.3	
Travel Time (s)		20.5			18.3			15.2			12.3	
Confl. Peds. (#/hr)	13		11	11		13	11		28	28		11
Confl. Bikes (#/hr)												
Peak Hour Factor	0.94	0.94	0.94	0.94	0.94	0.94	0.94	0.94	0.94	0.94	0.94	0.94
Growth Factor	100%	100%	100%	100%	100%	100%	100%	100%	100%	100%	100%	100%
Heavy Vehicles (%)	3%	3%	0%	0%	2%	2%	2%	2%	2%	2%	1%	2%
Bus Blockages (#/hr)	0	0	4	0	0	4	0	0	4	0	0	4
Parking (#/hr)												
Mid-Block Traffic (%)		0%			0%			0%			0%	
Adj. Flow (vph)	124	913	147	128	1468	107	187	393	143	210	367	187
Shared Lane Traffic (%)												
Lane Group Flow (vph)	124	1060	0	128	1468	107	187	536	0	210	367	187
Enter Blocked Intersection	No	No	No	No	No	No	No	No	No	No	No	No
Lane Alignment	Left	Left	Right	Left	Left	Right	Left	Left	Right	Left	Left	Right
Median Width(m)		3.5			3.5			3.5			3.5	
Link Offset(m)		0.0			0.0			0.0			0.0	
Crosswalk Width(m)		4.8			4.8			4.8			4.8	
Two way Left Turn Lane												
Headway Factor	1.01	1.01	1.01	1.01	1.01	1.04	1.01	1.01	1.01	1.01	1.01	1.04
Turning Speed (k/h)	25		15	25		15	25		15	25		15
Turn Type	pm+pt	NA		pm+pt	NA	Perm	pm+pt	NA		pm+pt	NA	Perm
Protected Phases	5	2		1	6		7	4		3	8	
Permitted Phases	2			6		6	4			8		8
Detector Phase	5	2		1	6	6	7	4		3	8	8
Switch Phase												
Minimum Initial (s)	8.0	12.0		8.0	12.0	12.0	8.0	12.0		8.0	12.0	12.0
Minimum Split (s)	11.0	35.1		11.0	35.1	35.1	11.0	38.9		11.0	38.9	38.9
Total Split (s)	13.0	74.0		11.0	72.0	72.0	14.0	58.0		17.0	61.0	61.0
Total Split (%)	8.1%	46.3%		6.9%	45.0%	45.0%	8.8%	36.3%		10.6%	38.1%	38.1%
Maximum Green (s)	10.0	66.9		8.0	64.9	64.9	11.0	50.1		14.0	53.1	53.1
Yellow Time (s)	3.0	4.0		3.0	4.0	4.0	3.0	4.0		3.0	4.0	4.0
All-Red Time (s)	0.0	3.1		0.0	3.1	3.1	0.0	3.9		0.0	3.9	3.9
Lost Time Adjust (s)	-1.0	-5.0		-1.0	-5.0	-1.0	-1.0	-5.0		-1.0	-5.0	-1.0

Lanes, Volumes, Timings

3: Queen Street S/Queen Street N & Britannia Road W

01-17-2023



Lane Group	EBL	EBT	EBR	WBL	WBT	WBR	NBL	NBT	NBR	SBL	SBT	SBR
Total Lost Time (s)	2.0	2.1		2.0	2.1	6.1	2.0	2.9		2.0	2.9	6.9
Lead/Lag	Lead	Lag		Lead	Lag	Lag	Lead	Lag		Lead	Lag	Lag
Lead-Lag Optimize?	Yes	Yes		Yes	Yes	Yes	Yes	Yes		Yes	Yes	Yes
Vehicle Extension (s)	3.0	3.0		3.0	3.0	3.0	3.0	3.0		3.0	3.0	3.0
Minimum Gap (s)	3.0	3.0		3.0	3.0	3.0	3.0	3.0		3.0	3.0	3.0
Time Before Reduce (s)	0.0	0.0		0.0	0.0	0.0	0.0	0.0		0.0	0.0	0.0
Time To Reduce (s)	0.0	0.0		0.0	0.0	0.0	0.0	0.0		0.0	0.0	0.0
Recall Mode	None	C-Max		None	Max	Max	None	None		None	None	None
Walk Time (s)		8.0			8.0	8.0		9.0			9.0	9.0
Flash Dont Walk (s)		20.0			20.0	20.0		22.0			22.0	22.0
Pedestrian Calls (#/hr)		0			0	0		0			0	0
Act Effct Green (s)	97.9	85.1		95.2	83.7	79.7	52.4	39.5		57.4	42.5	38.5
Actuated g/C Ratio	0.61	0.53		0.60	0.52	0.50	0.33	0.25		0.36	0.27	0.24
v/c Ratio	0.65	0.59		0.44	0.80	0.14	0.89	0.64		0.82	0.74	0.40
Control Delay	45.1	28.2		18.9	37.0	9.9	77.1	53.0		61.9	62.8	16.5
Queue Delay	0.0	0.0		0.0	0.0	0.0	0.0	0.0		0.0	0.0	0.0
Total Delay	45.1	28.2		18.9	37.0	9.9	77.1	53.0		61.9	62.8	16.5
LOS	D	C		B	D	A	E	D		E	E	B
Approach Delay		30.0			34.0			59.2			51.2	
Approach LOS		C			C			E			D	
Queue Length 50th (m)	21.6	122.2		17.0	208.2	5.6	45.0	79.7		51.2	113.3	13.6
Queue Length 95th (m)	47.5	172.3		31.7	#301.3	19.9	#68.0	92.1		#71.8	139.2	34.5
Internal Link Dist (m)		260.8			229.5			145.0			112.3	
Turn Bay Length (m)	130.0			60.0		40.0	40.0			65.0		65.0
Base Capacity (vph)	197	1806		292	1830	778	210	1163		256	675	595
Starvation Cap Reductn	0	0		0	0	0	0	0		0	0	0
Spillback Cap Reductn	0	0		0	0	0	0	0		0	0	0
Storage Cap Reductn	0	0		0	0	0	0	0		0	0	0
Reduced v/c Ratio	0.63	0.59		0.44	0.80	0.14	0.89	0.46		0.82	0.54	0.31

Intersection Summary





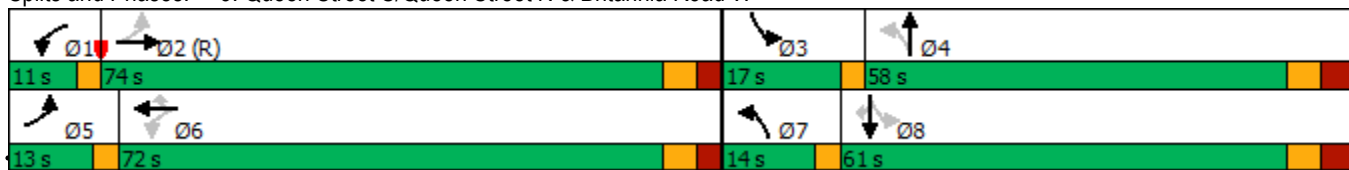











Area Type: Other
 Cycle Length: 160
 Actuated Cycle Length: 160
 Offset: 114 (71%), Referenced to phase 2:EBTL, Start of Green
 Natural Cycle: 110
 Control Type: Actuated-Coordinated
 Maximum v/c Ratio: 0.89
 Intersection Signal Delay: 40.1 Intersection LOS: D
 Intersection Capacity Utilization 90.7% ICU Level of Service E
 Analysis Period (min) 15
 # 95th percentile volume exceeds capacity, queue may be longer.
 Queue shown is maximum after two cycles.

Splits and Phases: 3: Queen Street S/Queen Street N & Britannia Road W



HCM Unsignalized Intersection Capacity Analysis
6: Queen Street S & Private Access/Ellen Street

01-17-2023

												
Movement	EBL	EBT	EBR	WBL	WBT	WBR	NBL	NBT	NBR	SBL	SBT	SBR
Lane Configurations												
Traffic Volume (veh/h)	7	0	1	28	0	15	1	671	24	6	585	8
Future Volume (Veh/h)	7	0	1	28	0	15	1	671	24	6	585	8
Sign Control		Stop			Stop			Free			Free	
Grade		0%			0%			0%			0%	
Peak Hour Factor	0.92	0.92	0.92	0.92	0.92	0.92	0.92	0.92	0.92	0.92	0.92	0.92
Hourly flow rate (vph)	8	0	1	30	0	16	1	729	26	7	636	9
Pedestrians		8			9			3				
Lane Width (m)		3.5			3.5			3.5				
Walking Speed (m/s)		1.2			1.2			1.2				
Percent Blockage		1			1			0				
Right turn flare (veh)												
Median type								None			None	
Median storage veh												
Upstream signal (m)												331
pX, platoon unblocked	0.82	0.82	0.82	0.82	0.82		0.82					
vC, conflicting volume	1422	1428	652	1412	1420	751	653			764		
vC1, stage 1 conf vol												
vC2, stage 2 conf vol												
vCu, unblocked vol	1406	1413	469	1392	1403	751	471			764		
tC, single (s)	7.2	6.5	6.2	7.1	6.5	6.2	5.1			4.1		
tC, 2 stage (s)												
tF (s)	3.6	4.0	3.3	3.5	4.0	3.3	3.1			2.2		
p0 queue free %	91	100	100	69	100	96	100			99		
cM capacity (veh/h)	85	112	488	96	113	411	593			852		
Direction, Lane #	EB 1	WB 1	NB 1	SB 1								
Volume Total	9	46	756	652								
Volume Left	8	30	1	7								
Volume Right	1	16	26	9								
cSH	93	131	593	852								
Volume to Capacity	0.10	0.35	0.00	0.01								
Queue Length 95th (m)	2.5	11.4	0.0	0.2								
Control Delay (s)	47.6	46.6	0.0	0.2								
Lane LOS	E	E	A	A								
Approach Delay (s)	47.6	46.6	0.0	0.2								
Approach LOS	E	E										
Intersection Summary												
Average Delay			1.9									
Intersection Capacity Utilization			48.4%		ICU Level of Service				A			
Analysis Period (min)			15									

HCM Unsignalized Intersection Capacity Analysis

9: Queen Street S & James Street

01-17-2023



Movement	EBL	EBR	NBL	NBT	SBT	SBR
Lane Configurations						
Traffic Volume (veh/h)	17	22	38	655	577	26
Future Volume (Veh/h)	17	22	38	655	577	26
Sign Control	Stop			Free	Free	
Grade	0%			0%	0%	
Peak Hour Factor	0.93	0.93	0.93	0.93	0.93	0.93
Hourly flow rate (vph)	18	24	41	704	620	28
Pedestrians	6					
Lane Width (m)	3.5					
Walking Speed (m/s)	1.2					
Percent Blockage	0					
Right turn flare (veh)						
Median type				None	None	
Median storage veh						
Upstream signal (m)					169	
pX, platoon unblocked	0.79	0.79	0.79			
vC, conflicting volume	1426	640	654			
vC1, stage 1 conf vol						
vC2, stage 2 conf vol						
vCu, unblocked vol	1407	417	435			
tC, single (s)	6.4	6.2	4.1			
tC, 2 stage (s)						
tF (s)	3.5	3.3	2.2			
p0 queue free %	85	95	95			
cM capacity (veh/h)	117	506	898			
Direction, Lane #	EB 1	NB 1	SB 1			
Volume Total	42	745	648			
Volume Left	18	41	0			
Volume Right	24	0	28			
cSH	208	898	1700			
Volume to Capacity	0.20	0.05	0.38			
Queue Length 95th (m)	5.9	1.1	0.0			
Control Delay (s)	26.6	1.2	0.0			
Lane LOS	D	A				
Approach Delay (s)	26.6	1.2	0.0			
Approach LOS	D					
Intersection Summary						
Average Delay			1.4			
Intersection Capacity Utilization			75.5%	ICU Level of Service	D	
Analysis Period (min)			15			

HCM Unsignalized Intersection Capacity Analysis

10: William Street & James Street

01-17-2023



Movement	WBL	WBR	NBT	NBR	SBL	SBT
Lane Configurations						
Traffic Volume (veh/h)	18	0	0	12	0	0
Future Volume (Veh/h)	18	0	0	12	0	0
Sign Control	Stop		Free		Free	
Grade	0%		0%		0%	
Peak Hour Factor	0.92	0.92	0.92	0.92	0.92	0.92
Hourly flow rate (vph)	20	0	0	13	0	0
Pedestrians						
Lane Width (m)						
Walking Speed (m/s)						
Percent Blockage						
Right turn flare (veh)						
Median type	None			None		
Median storage veh						
Upstream signal (m)						
pX, platoon unblocked						
vC, conflicting volume	0	0			13	
vC1, stage 1 conf vol						
vC2, stage 2 conf vol						
vCu, unblocked vol	0	0			13	
tC, single (s)	6.4	6.2			4.1	
tC, 2 stage (s)						
tF (s)	3.5	3.3			2.2	
p0 queue free %	98	100			100	
cM capacity (veh/h)	1029	1091			1619	
Direction, Lane #	WB 1	NB 1	SB 1			
Volume Total	20	13	0			
Volume Left	20	0	0			
Volume Right	0	13	0			
cSH	1029	1700	1700			
Volume to Capacity	0.02	0.01	0.00			
Queue Length 95th (m)	0.5	0.0	0.0			
Control Delay (s)	8.6	0.0	0.0			
Lane LOS	A					
Approach Delay (s)	8.6	0.0	0.0			
Approach LOS	A					
Intersection Summary						
Average Delay			5.2			
Intersection Capacity Utilization			6.7%	ICU Level of Service	A	
Analysis Period (min)			15			

HCM Unsignalized Intersection Capacity Analysis

13: James Street & Site Access

01-17-2023



Movement	EBL	EBT	WBT	WBR	SBL	SBR
Lane Configurations						
Traffic Volume (veh/h)	5	9	13	51	20	5
Future Volume (Veh/h)	5	9	13	51	20	5
Sign Control		Free	Free		Stop	
Grade		0%	0%		0%	
Peak Hour Factor	0.92	0.92	0.92	0.92	0.92	0.92
Hourly flow rate (vph)	5	10	14	55	22	5
Pedestrians		20	20		20	
Lane Width (m)		3.5	3.5		3.5	
Walking Speed (m/s)		1.2	1.2		1.2	
Percent Blockage		2	2		2	
Right turn flare (veh)						
Median type		None	None			
Median storage (veh)						
Upstream signal (m)						
pX, platoon unblocked						
vC, conflicting volume	89				102	82
vC1, stage 1 conf vol						
vC2, stage 2 conf vol						
vCu, unblocked vol	89				102	82
tC, single (s)	4.1				6.4	6.2
tC, 2 stage (s)						
tF (s)	2.2				3.5	3.3
p0 queue free %	100				97	99
cM capacity (veh/h)	1482				865	947
Direction, Lane #	EB 1	WB 1	SB 1			
Volume Total	15	69	27			
Volume Left	5	0	22			
Volume Right	0	55	5			
cSH	1482	1700	879			
Volume to Capacity	0.00	0.04	0.03			
Queue Length 95th (m)	0.1	0.0	0.8			
Control Delay (s)	2.5	0.0	9.2			
Lane LOS	A		A			
Approach Delay (s)	2.5	0.0	9.2			
Approach LOS			A			
Intersection Summary						
Average Delay			2.6			
Intersection Capacity Utilization			24.1%	ICU Level of Service	A	
Analysis Period (min)			15			

Lanes, Volumes, Timings

3: Queen Street S/Queen Street N & Britannia Road W

01-17-2023



Lane Group	EBL	EBT	EBR	WBL	WBT	WBR	NBL	NBT	NBR	SBL	SBT	SBR
Lane Configurations												
Traffic Volume (vph)	117	858	138	120	1380	101	176	369	134	197	345	176
Future Volume (vph)	117	858	138	120	1380	101	176	369	134	197	345	176
Ideal Flow (vphpl)	1900	1900	1900	1900	1900	1900	1900	1900	1900	1900	1900	1900
Lane Width (m)	3.5	3.5	3.5	3.5	3.5	3.5	3.5	3.5	3.5	3.5	3.5	3.5
Grade (%)		0%			0%			0%			0%	
Storage Length (m)	130.0		0.0	60.0		40.0	40.0		0.0	65.0		65.0
Storage Lanes	1		0	1		1	1		0	1		1
Taper Length (m)	7.5			7.5			7.5			7.5		
Satd. Flow (prot)	1733	3383	0	1785	3500	1541	1750	3311	0	1750	1860	1541
Flt Permitted	0.054			0.146			0.149			0.291		
Satd. Flow (perm)	99	3383	0	274	3500	1489	273	3311	0	526	1860	1496
Right Turn on Red			Yes			Yes			Yes			Yes
Satd. Flow (RTOR)		14				95		38				155
Link Speed (k/h)		50			50			40				40
Link Distance (m)		284.8			253.5			169.0				136.3
Travel Time (s)		20.5			18.3			15.2				12.3
Confl. Peds. (#/hr)	13		11	11		13	11		28	28		11
Confl. Bikes (#/hr)												
Peak Hour Factor	0.94	0.94	0.94	0.94	0.94	0.94	0.94	0.94	0.94	0.94	0.94	0.94
Growth Factor	100%	100%	100%	100%	100%	100%	100%	100%	100%	100%	100%	100%
Heavy Vehicles (%)	3%	3%	0%	0%	2%	2%	2%	2%	2%	2%	1%	2%
Bus Blockages (#/hr)	0	0	4	0	0	4	0	0	4	0	0	4
Parking (#/hr)												
Mid-Block Traffic (%)		0%			0%			0%			0%	
Adj. Flow (vph)	124	913	147	128	1468	107	187	393	143	210	367	187
Shared Lane Traffic (%)												
Lane Group Flow (vph)	124	1060	0	128	1468	107	187	536	0	210	367	187
Enter Blocked Intersection	No	No	No	No	No	No	No	No	No	No	No	No
Lane Alignment	Left	Left	Right	Left	Left	Right	Left	Left	Right	Left	Left	Right
Median Width(m)		3.5			3.5			3.5			3.5	
Link Offset(m)		0.0			0.0			0.0			0.0	
Crosswalk Width(m)		4.8			4.8			4.8			4.8	
Two way Left Turn Lane												
Headway Factor	1.01	1.01	1.01	1.01	1.01	1.04	1.01	1.01	1.01	1.01	1.01	1.04
Turning Speed (k/h)	25		15	25		15	25		15	25		15
Turn Type	pm+pt	NA		pm+pt	NA	Perm	pm+pt	NA		pm+pt	NA	Perm
Protected Phases	5	2		1	6		7	4		3	8	
Permitted Phases	2			6		6	4			8		8
Detector Phase	5	2		1	6	6	7	4		3	8	8
Switch Phase												
Minimum Initial (s)	8.0	12.0		8.0	12.0	12.0	8.0	12.0		8.0	12.0	12.0
Minimum Split (s)	11.0	35.1		11.0	35.1	35.1	11.0	38.9		11.0	38.9	38.9
Total Split (s)	11.0	67.0		11.0	67.0	67.0	23.0	66.0		16.0	59.0	59.0
Total Split (%)	6.9%	41.9%		6.9%	41.9%	41.9%	14.4%	41.3%		10.0%	36.9%	36.9%
Maximum Green (s)	8.0	59.9		8.0	59.9	59.9	20.0	58.1		13.0	51.1	51.1
Yellow Time (s)	3.0	4.0		3.0	4.0	4.0	3.0	4.0		3.0	4.0	4.0
All-Red Time (s)	0.0	3.1		0.0	3.1	3.1	0.0	3.9		0.0	3.9	3.9
Lost Time Adjust (s)	-1.0	-5.0		-1.0	-5.0	-1.0	-1.0	-5.0		-1.0	-5.0	-1.0

Lanes, Volumes, Timings

3: Queen Street S/Queen Street N & Britannia Road W

01-17-2023



Lane Group	EBL	EBT	EBR	WBL	WBT	WBR	NBL	NBT	NBR	SBL	SBT	SBR
Total Lost Time (s)	2.0	2.1		2.0	2.1	6.1	2.0	2.9		2.0	2.9	6.9
Lead/Lag	Lead	Lag		Lead	Lag	Lag	Lead	Lag		Lead	Lag	Lag
Lead-Lag Optimize?	Yes	Yes		Yes	Yes	Yes	Yes	Yes		Yes	Yes	Yes
Vehicle Extension (s)	3.0	3.0		3.0	3.0	3.0	3.0	3.0		3.0	3.0	3.0
Minimum Gap (s)	3.0	3.0		3.0	3.0	3.0	3.0	3.0		3.0	3.0	3.0
Time Before Reduce (s)	0.0	0.0		0.0	0.0	0.0	0.0	0.0		0.0	0.0	0.0
Time To Reduce (s)	0.0	0.0		0.0	0.0	0.0	0.0	0.0		0.0	0.0	0.0
Recall Mode	None	C-Max		None	Max	Max	None	None		None	None	None
Walk Time (s)		8.0			8.0	8.0		9.0			9.0	9.0
Flash Dont Walk (s)		20.0			20.0	20.0		22.0			22.0	22.0
Pedestrian Calls (#/hr)		0			0	0		0			0	0
Act Effct Green (s)	91.3	78.3		89.2	77.3	73.3	63.3	46.8		57.2	42.3	38.3
Actuated g/C Ratio	0.57	0.49		0.56	0.48	0.46	0.40	0.29		0.36	0.26	0.24
v/c Ratio	0.66	0.64		0.48	0.87	0.15	0.67	0.54		0.71	0.75	0.39
Control Delay	48.7	34.1		23.9	44.6	7.7	43.2	44.9		46.5	63.1	12.5
Queue Delay	0.0	0.0		0.0	0.0	0.0	0.0	0.0		0.0	0.0	0.0
Total Delay	48.7	34.1		23.9	44.6	7.7	43.2	44.9		46.5	63.1	12.5
LOS	D	C		C	D	A	D	D		D	E	B
Approach Delay		35.6			40.8			44.5			46.1	
Approach LOS		D			D			D			D	
Queue Length 50th (m)	23.4	137.6		19.3	233.1	2.2	41.5	73.4		47.3	113.5	8.4
Queue Length 95th (m)	#56.3	187.2		36.0	#321.2	16.1	53.9	83.0		60.2	139.5	28.8
Internal Link Dist (m)		260.8			229.5			145.0			112.3	
Turn Bay Length (m)	130.0			60.0		40.0	40.0			65.0		65.0
Base Capacity (vph)	188	1662		265	1690	733	302	1328		295	652	591
Starvation Cap Reductn	0	0		0	0	0	0	0		0	0	0
Spillback Cap Reductn	0	0		0	0	0	0	0		0	0	0
Storage Cap Reductn	0	0		0	0	0	0	0		0	0	0
Reduced v/c Ratio	0.66	0.64		0.48	0.87	0.15	0.62	0.40		0.71	0.56	0.32

Intersection Summary

Area Type: Other
 Cycle Length: 160
 Actuated Cycle Length: 160
 Offset: 114 (71%), Referenced to phase 2:EBTL, Start of Green
 Natural Cycle: 110
 Control Type: Actuated-Coordinated
 Maximum v/c Ratio: 0.87
 Intersection Signal Delay: 40.9
 Intersection LOS: D
 Intersection Capacity Utilization 90.7%
 ICU Level of Service E
 Analysis Period (min) 15

95th percentile volume exceeds capacity, queue may be longer.
 Queue shown is maximum after two cycles.

Splits and Phases: 3: Queen Street S/Queen Street N & Britannia Road W

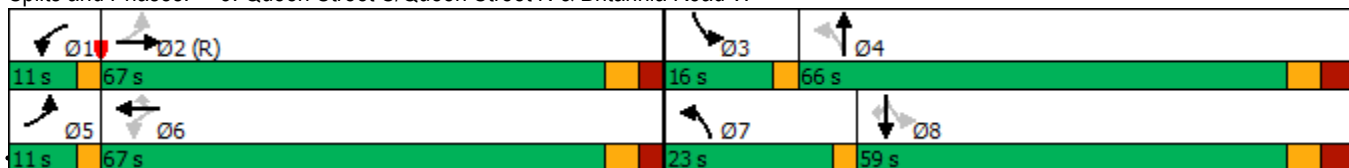

Appendix G

City of Mississauga Zoning By-Law

TABLE OF CONTENTS
Part 3: Parking, Loading, Stacking Lane and
Bicycle Parking Regulations

3.1	PARKING, LOADING, STACKING LANE AND BICYCLE PARKING REGULATIONS	3.1 ~ 1 to 24
3.1.1	Parking Regulations	3.1 ~ 1
3.1.1.1	General Parking Regulations.....	3.1 ~ 1
3.1.1.2	Location of Parking.....	3.1 ~ 1
3.1.1.3	Required Parking in a Residential Zone.....	3.1 ~ 1
3.1.1.4	Parking Space Dimensions.....	3.1 ~ 2
3.1.1.5	Aisles.....	3.1 ~ 2
3.1.1.6	Driveways	3.1 ~ 2
3.1.1.7	Surface Treatment and Drainage.....	3.1 ~ 3
3.1.1.8	Access	3.1 ~ 3
3.1.1.9	Alternative Gross Floor Area Deductions for Non-Residential Uses	3.1 ~ 3
3.1.1.10	Retail Centre.....	3.1 ~ 3
3.1.1.11	Parking for Additional Uses in a Public or Private School	3.1 ~ 3
3.1.1.11.1	Parking for a Place of Religious Assembly.....	3.1 ~ 3
3.1.1.11.2	Parking for any other Permitted Non-Residential Use.....	3.1 ~ 3
3.1.1.12	Electric Vehicle Ready Parking Spaces	3.1 ~ 4
3.1.2	Required Number of Parking Spaces	3.1 ~ 5
3.1.2.1	Required Number of Parking Spaces for Residential Uses	3.1 ~ 5
3.1.2.1.3	Shared Arrangement for Residential Visitor and Non-Residential Parking Component.....	3.1 ~ 6
3.1.2.2	Required Number of Parking Spaces for Non-Residential Uses.....	3.1 ~ 7
3.1.2.3	C4 Zone Parking Requirement.....	3.1 ~ 16
3.1.2.4	Mixed Use Development Shared Parking	3.1 ~ 16
3.1.3	Accessible Parking Spaces	3.1 ~ 17
3.1.3.1	Required Number of Accessible Parking Spaces	3.1 ~ 17
3.1.3.2	Location of Accessible Parking Spaces.....	3.1 ~ 18
3.1.3.3	<i>deleted by 0117-2022</i>	3.1 ~ 18
3.1.4	Loading Regulations.....	3.1 ~ 18
3.1.4.1	Loading Space Regulations.....	3.1 ~ 18
3.1.4.2	Required Number of Loading Spaces for Office and Medical Office Buildings	3.1 ~ 18
3.1.4.3	Required Number of Loading Spaces	3.1 ~ 19
3.1.4.4	Loading Space Dimensions.....	3.1 ~ 19
3.1.4.5	Required Number of Loading Spaces for Apartment and/or Retirement Buildings.....	3.1 ~ 19
3.1.5	Stacking Lane Regulations	3.1 ~ 19
3.1.6	Bicycle Parking Regulations	3.1 ~ 20
3.1.6.1	General Bicycle Parking Regulations.....	3.1 ~ 20
3.1.6.2	Location of Bicycle Parking.....	3.1 ~ 20
3.1.6.3	Bicycle Parking Space Dimensions.....	3.1 ~ 20
3.1.6.4	Bicycle Parking Aisles	3.1 ~ 20
3.1.6.5	Required Number of Bicycle Parking Spaces	3.1 ~ 21
3.1.6.5.1	Required Number of Bicycle Parking Spaces for Residential Uses.....	3.1 ~ 21
3.1.6.6	Required Number of Bicycle Parking Spaces for Non-Residential Uses.....	3.1 ~ 21

3.1 PARKING, LOADING, STACKING LANE AND BICYCLE PARKING REGULATIONS

3.1.1 Parking Regulations

3.1.1.1 General Parking Regulations

3.1.1.1.1 No land, **building** or **structure** shall be erected or used in any Zone, unless off-street parking, loading and **bicycle** parking is provided and maintained in accordance with the regulations contained in Part 3 - Parking, Loading, Stacking Lane and Bicycle Parking Regulations. (0118-2022)

3.1.1.1.2 Where required, **parking spaces** provided for persons with disabilities and for **electric vehicle ready parking spaces** shall be included in the total number of required **parking spaces**. (0117-2022)

3.1.1.1.3 Required **parking spaces** shall not include any **parking spaces** used or intended to be used for the storage or parking of **motor vehicles** for hire or gain, display or sale.

3.1.1.1.4 Where the number of non-residential **parking spaces** and/or **loading spaces** and/or **bicycle parking spaces** is calculated on the basis of a rate or ratio and results in a numeric fraction, fractions of less than 0.5 shall be rounded down to the nearest whole number and fractions equal to or greater than 0.5 shall be rounded up to the nearest whole number. For **accessible parking spaces**, all numeric fractions shall be rounded up to the nearest whole number. (0190-2014), (0118-2022)

3.1.1.1.5 For the calculation of required residential parking and **bicycle parking spaces**, the appropriate rate or ratio shall be calculated for each component, then rounded. Fractions of less than 0.5 shall be rounded down to the nearest whole number. Fractions equal to or greater than 0.5 shall be rounded up to the nearest whole number. (0379-2009), (0118-2022)

3.1.1.1.6 No **use** shall be located on any required **parking area** or obstruct any required **parking space**.

3.1.1.1.7 All required **parking spaces** must be available to all users participating in any shared parking arrangement and may not be reserved for specific users. (0207-2008), (0018-2021)

3.1.1.1.8 Notwithstanding Sentences 1.1.2.3.1 and 3.1.1.1.1 of this By-law, on a **lot** with an Exception Zone, or subject to area specific provisions in this By-law, or where a minor variance has been approved by the Committee of Adjustment on or before June 8, 2022, the off-street parking requirement will be calculated based on the lesser rate or ratio between the regulations contained in Part 3 of this By-law and the off-street parking requirement identified in the Exception Zone, area specific provisions or minor variance. (0117-2022)

3.1.1.1.9 The Parking Precincts are shown as an outline on the Zoning Maps which are Schedule B of Part 13 of this By-law. (0117-2022)

3.1.1.2 Location of Parking

3.1.1.2.1 All **parking, loading spaces** and **electric vehicle ready parking spaces** shall be provided, maintained and be clearly identified and marked by permanent lines and markings painted on the paved surface on the same **lot** for which the **parking, loading spaces** and **electric vehicle ready parking spaces** are required. (0117-2022)

3.1.1.2.2 Visitor **parking spaces** shall be clearly indicated by a sign at the entrance to the **parking area** and clearly identified and marked by permanent lines and markings painted on the paved surface.

3.1.1.3 Required Parking in a Residential Zone

For a residential **use** in a Residential Zone:
(0308-2011)

3.1.1.3.1 A **parking space** on a **driveway** serving as an access to a **parking space** within a **garage** may be included in the calculation of the number of **parking spaces** required.

3.1.1.3.2 Where visitor **parking spaces** are required, a **parking space** on a **driveway** shall not be used for calculating the required visitor parking.

3.1.1.4 Parking Space Dimensions

3.1.1.4.1 **Parking spaces** with a parking angle exceeding 15°, except those designated for persons with disabilities, shall have an unobstructed rectangular area with a minimum width of 2.6 m and a minimum length of 5.2 m, exclusive of any **aisle** or **driveway**.

See Illustration No. 8 - Section 1.3 - Illustrations

3.1.1.4.2 **Parallel parking spaces** with a parking angle not exceeding 15°, shall have an unobstructed rectangular area with a minimum width of 2.6 m and a minimum length of 6.7 m, exclusive of any **aisle** or **driveway**.

See Illustration No. 8 - Section 1.3 - Illustrations

3.1.1.4.3 The minimum width of a **parking space**, other than an **accessible parking space** or **parallel parking space**, shall be increased to 2.75 m where the length of one side of the **parking space** abuts a **building, structure** or part thereof, except for a **building, structure** or part thereof, that extends 1.0 m or less into the front and/or rear of the **parking space**.

See Illustration No. 13 - Section 1.3 - Illustrations

3.1.1.4.4 The minimum width of a **parking space**, other than an **accessible parking space** or **parallel parking space**, shall be increased to 2.9 m where the length of both sides of the **parking space** abuts a **building, structure** or part thereof, except for a **building, structure** or part thereof, that extends 1.0 m or less into the front and/or rear of the **parking space**.

See Illustration No. 13 - Section 1.3 - Illustrations

3.1.1.4.5 **Accessible parking spaces** are to be provided in two sizes and maintain a 1.5 m wide access **aisle** abutting the entire length of each **parking space**: (0190-2014)

- (1) Type A shall have an unobstructed rectangular area with a minimum width of 3.4 m and a minimum length of 5.2 m.
- (2) Type B shall have an unobstructed rectangular area with a minimum width of 2.4 m and a minimum length of 5.2 m.
- (3) An access **aisle** is required to abut each **accessible parking space**. Where two or more **accessible parking spaces** are required in accordance with the regulations contained in Table 3.1.3.1 of this By-law, the access **aisle** may be shared between the **accessible parking spaces**.

See Illustration No. 15 - Section 1.3 Illustrations

3.1.1.4.6 Parallel **accessible parking spaces** with a parking angle not exceeding 15°, shall have an unobstructed rectangular area with a minimum width of 4.6 m and a minimum length of 5.75 m, and maintain a 1.5 m width access **aisle** abutting the entire width of each **accessible parking space**. (0174-2017)

See Illustration No. 15 - Section 1.3 Illustrations

3.1.1.5 Aisles

3.1.1.5.1 The minimum **aisle** width shall be 7.0 m.

3.1.1.5.2 Notwithstanding Sentence 3.1.1.5.1, where a one-way **aisle** is provided for access to and from **parking spaces** with a **parking angle** not exceeding 60°, the minimum **aisle** width may be 5.5 m.

See Illustration No. 8 - Section 1.3 - Illustrations

3.1.1.6 Driveways

The minimum width of a **driveway** shall be 2.6 m.

3.1.1.7 Surface Treatment and Drainage

3.1.1.7.1 All **parking areas, driveways** and loading areas shall have a minimum overall **vertical depth** of 15.0 cm comprised of a stable surface such as asphalt, concrete, **pervious materials** or other hard-surfaced material. (0212-2015)

3.1.1.7.2 All **parking areas, driveways** and loading areas shall be drained so as to control the pooling of surface water and prevent the flow of surface water onto adjacent lands.

3.1.1.8 Access

3.1.1.8.1 Access to and from **parking and loading spaces** shall be provided by unobstructed on-site **driveways or driveways and aisles**. (0297-2013)

3.1.1.8.2 Notwithstanding the regulations of Sentence 3.1.1.8.1, an on-site **aisle** is not required for **lots used for detached dwelling, semi-detached, linked, street townhouse; detached dwelling, semi-detached and townhouse on a CEC - road; or a duplex**. (0297-2013), (0174-2017), (0181-2018/LPAT Order 2019 February 15), (0111-2019/LPAT Order 2021 March 09)

3.1.1.9 Alternative Gross Floor Area Deductions for Non-Residential Uses

For the purposes of calculating required parking for a non-residential **use, gross floor area**, as defined by this By-law, may be used instead of **gross floor area - non-residential** as contained in Table 3.1.2.2 of this By-law and the following deductions to the total **gross floor area** calculated shall apply: 2% for **manufacturing facility and warehouse/distribution facility, wholesaling facility**, 10% for **office and medical office uses** and 5% for all other non-residential **uses**.

3.1.1.10 Retail Centre

3.1.1.10.1 A retail centre shall include permitted Retail, Service, Office, Hospitality or Entertainment/Recreation **uses** identified in Table 6.2.1 of this By-law, occupying three or more separated units on one property in a C1, C2, C3 and CC1 zone, where the **gross floor area - non-residential** is primarily used for permitted **uses** that require a parking regulation of 5.4 spaces per 100 m² **GFA - non-residential** or less, as identified in Part 3 of this By-law. (0379-2009), (0212-2015)

3.1.1.10.2 For the calculation of required parking for a retail centre, in addition to any deductions permitted by the definition of **gross floor area - non-residential**, an **enclosed pedestrian mall, a food court**, and any corridor not open to the public and used by more than one tenant of the **building** may be deducted from the total **gross floor area - non-residential** prior to calculating required parking. (0379-2009), (0174-2017)

3.1.1.11 Parking for Additional Uses in a Public or Private School

3.1.1.11.1 Parking for a Place of Religious Assembly

Where any part of a **public school or private school** is used as a place of public worship or for the conduct of religious activities on a weekly or other frequent and regular basis in compliance with the provisions of this By-law, and such public worship or religious activity is not part of the school curriculum or is attended by persons not enrolled or employed in the school, the portion of the **public school or private school** used for public worship or religious activity shall be deemed to be a **place of religious assembly** for the purpose of calculating required parking. When parking for multiple **uses** is calculated, the parking regulation will not be cumulative, but the higher parking regulation will apply.

3.1.1.11.2 Parking for any other Permitted Non-Residential Use

Where any part of a **public school or private school** is shared with any other permitted non-residential land **use**, the portion of the **public school or private school** used for the said **use** shall provide the required parking in accordance with the minimum parking regulations of the respective **uses**. When parking for multiple **uses** is calculated, the parking regulation will not be cumulative, but the higher parking regulation will apply. (0325-2008)

3.1.1.12 Electric Vehicle Ready Parking Spaces

3.1.1.12.1 **Electric vehicle ready parking spaces** shall be provided in accordance with Table 3.1.1.12 - Minimum Required Number of Electric Vehicle Ready Parking Spaces. (0117-2022)

Table 3.1.1.12 - Minimum Required Number of Electric Vehicle Ready Parking Spaces

Column A		B
Line 1.0	TYPE OF USE	MINIMUM NUMBER OF REQUIRED ELECTRIC VEHICLE READY PARKING SPACES
2.0	Detached Dwelling, Linked Dwelling, Semi-Detached, Street Townhouse, Duplex, Triplex, Back to Back and Stacked Townhouse	1.0 of the required parking spaces with an exclusive use garage
3.0	Condominium and Rental Apartment , resident parking	20% of the total required parking spaces or 1.0 space, whichever is greater
4.0	Condominium and Rental Apartment , visitor parking	10% of the total required parking spaces or 1.0 space, whichever is greater
5.0	Back to back and stacked townhouse , without exclusive use garage and/or driveway	20% of the total required parking spaces or 1.0 space, whichever is greater
6.0	Non-residential uses identified in Table 3.1.2.2 of this By-law, with a parking structure with 10 or more parking spaces	10% of the total required parking spaces or 1.0 space, whichever is greater

3.1.1.12.2 Notwithstanding Sentence 3.1.1.12.1 of this By-law, required **electric vehicle ready parking spaces** shall only be required for the construction of new **buildings**, or portions thereof, effective June 8, 2023.

3.1.1.12.3 Notwithstanding Sentence 3.1.1.12.1 of this By-law, **electric vehicle ready parking spaces** shall not be required for **transitional housing**.

3.1.1.12.4 Notwithstanding Sentence 3.1.1.12.2 of this By-law, **electric vehicle ready parking spaces** shall not be required for any additions to an **existing building** that adds three or less **dwelling units**.

3.1.2 Required Number of Parking Spaces

3.1.2.1 Required Number of Parking Spaces for Residential Uses

3.1.2.1.1 Off-street **parking spaces** for residential **uses** shall be provided in accordance with Table 3.1.2.1 - Required Number of Off-Street Parking Spaces for Residential Uses. (0117-2022)

Table 3.1.2.1 - Required Number of Off-Street Parking Spaces for Residential Uses
(0207-2008), (0297-2013), (0174-2017), (0179-2018), (0181-2018/LPAT Order 2019 February 15), (0111-2019/LPAT Order 2021 March 09), (0018-2021), (0117-2022)

Column A		B	C	D	E	F
Line 1.0	TYPE OF USE	UNIT OF MEASUREMENT	PRECINCT 1	PRECINCT 2	PRECINCT 3	PRECINCT 4
2.0	Condominium Apartment	resident spaces per unit	0.8	0.9	1.0	1.1
		visitor spaces per unit	0.2	0.2	0.2	0.2
3.0	Rental Apartment	resident spaces per unit	0.8	0.8	0.9	1.0
		visitor spaces per unit	0.2	0.2	0.2	0.2
4.0	Public authority dwelling unit or dwelling unit provided by a not-for profit housing provider in a rental apartment	resident spaces per unit	0.4	0.6	0.65	0.7
		visitor spaces per unit	0.2	0.2	0.2	0.2
5.0	Apartment (within CC1 to CC4 zones)	0.8 resident spaces per unit 0.15 visitor spaces per unit ⁽¹⁾				
6.0	Detached Dwelling, Linked Dwelling, Semi-Detached, Street Townhouse	spaces per unit	2.0	2.0	2.0	2.0
7.0	Condominium Detached Dwelling, Condominium Semi-Detached, Condominium Townhouse, Detached Dwelling on a CEC - Road, Semi-Detached on a CEC - Road, Townhouse on a CEC - Road	resident spaces per unit	2.0	2.0	2.0	2.0
		visitor spaces per unit	0.25	0.25	0.25	0.25
8.0	Duplex, Triplex	spaces per unit	1.25	1.25	1.25	1.25
9.0	Dwelling units located above a commercial development with a maximum height of three storeys	spaces per unit	1.0	1.0	1.0	1.0
10.0	Group Home	spaces per unit	2.0	2.0	2.0	2.0
11.0	Back to Back and Stacked Townhouse without exclusive use garage and driveway	resident spaces per unit	1.0	1.1	1.3	1.5
		visitor spaces per unit	0.25	0.25	0.25	0.25

Table 3.1.2.1 continued on next page

Part 3 - Parking, Loading and Stacking Lane Regulations

Column	A	B	C	D	E	F
Line 1.0	TYPE OF USE	UNIT OF MEASUREMENT	PRECINCT 1	PRECINCT 2	PRECINCT 3	PRECINCT 4
Table 3.1.2.1 continued from previous page						
12.0	Back to Back and Stacked Townhouse with exclusive use garage and driveway	resident spaces per unit	2.0	2.0	2.0	2.0
		visitor spaces per unit	0.25	0.25	0.25	0.25
13.0	Long-Term Care Building	spaces per bed	0.33	0.33	0.33	0.33
14.0	Retirement Building	spaces per unit	0.5	0.5	0.5	0.5
15.0	Public authority dwelling unit or dwelling unit provided by a not-for profit housing provider in a retirement building	spaces per unit	0.25	0.35	0.35	0.35
16.0	Transitional Housing	spaces per unit or sleeping rooms, whichever is greater	0.1	0.1	0.1	0.1
17.0	All other housing forms not identified above with more than two dwelling units	resident spaces per unit	2.0	2.0	2.0	2.0
		visitor spaces per unit	0.25	0.25	0.25	0.25

NOTES: (1) See Sentence 3.1.2.1.2 of this By-law.
(2) *deleted by 0117-2022*

3.1.2.1.2 Visitor **parking spaces** shall not be required for an **apartment** legally **existing** within CC1 to CC4 zones for which a building permit has been issued on or before May 29, 2009. *(0207-2008), (0174-2017), (0018-2021), (0117-2022)*

3.1.2.1.3 Shared Arrangement for Residential Visitor and Non-Residential Parking Component

For the purpose of Article 3.1.2.1 of this By-law, a shared parking arrangement may be used for the calculation of required residential visitor/non-residential parking in accordance with the following:
(0117-2022)

the greater of

- (1) Visitor spaces per unit in accordance with applicable regulations contained in Table 3.1.2.1 of this By-law;
- or
- (2) Parking required for all non-residential **uses**, located in the same **building** or on the same **lot** as the residential **use**, except **banquet hall/conference centre/convention centre, entertainment establishment, overnight accommodation, place of religious assembly, recreational establishment and restaurant over 220 m² GFA - non-residential.**

Parking for **banquet hall/conference centre/convention centre, entertainment establishment, overnight accommodation, place of religious assembly, recreational establishment and restaurant over 220 m² GFA - non-residential** shall not be included in the above shared parking arrangement and shall be provided in accordance with applicable regulations contained in Table 3.1.2.2 of this By-law.

3.1.2.2 Required Number of Parking Spaces for Non-Residential Uses

Off-street **parking spaces** for non-residential **uses** shall be provided in accordance with Table 3.1.2.2. - Required Number of Off-Street Parking Spaces for Non-Residential Uses. (0117-2022)

Table 3.1.2.2 - Required Number of Off-Street Parking Spaces for Non-Residential Uses
(0358-2007), (0207-2008), (0325-2008), (0379-2009), (0308-2011), (0190-2014), (0050-2013/LPAT Order 2020 June 08), (0018-2015), (0055-2015), (0212-2015), (0111-2019/LPAT Order 2021 March 09), (0018-2021), (0117-2022)

Column A		B	C	D	E	F
Line 1.0	TYPE OF USE	UNIT OF MEASUREMENT	PRECINCT 1	PRECINCT 2	PRECINCT 3	PRECINCT 4
2.0	Active Recreational Use	spaces per 100 m ² GFA - non-residential , except for an arena or a marina	4.5	4.5	4.5	4.5
3.0	Adult Entertainment Establishment	spaces per 100 m ² GFA - non-residential	16.3	16.3	16.3	16.3
4.0	Animal Services:					
4.1	Animal Boarding Establishment	spaces per 100 m ² GFA - non-residential	3.0	3.0	3.6	3.6
4.2	Animal Care Establishment	spaces per 100 m ² GFA - non-residential	3.0	3.0	4.0	5.0
5.0	Arena	space per four seats of permanent fixed seating ⁽¹⁾	1.0	1.0	1.0	1.0
6.0	Art Gallery, Museum	spaces per 100 m ² GFA - non-residential	3.0	3.0	3.6	3.6
7.0	Banquet Hall/ Conference Centre/ Convention Centre	spaces per 100 m ² GFA - non-residential	10.8	10.8	10.8	10.8
8.0	Commercial School	spaces per 100 m ² GFA - non-residential	5.0	5.0	5.0	5.0
9.0	Community Centre	spaces per 100 m ² GFA - non-residential , except for an arena	4.5	4.5	4.5	4.5
10.0	Composting Facility	spaces per 100 m ² GFA - non-residential up to 2 325 m ² GFA - non-residential ;	1.6	1.6	1.6	1.6
		and				
		spaces per 100 m ² GFA - non-residential between 2 325 m ² and 9 300 m ² GFA - non-residential ;	1.1	1.1	1.1	1.1
		and				
		spaces per 100 m ² GFA - non-residential over 9 300 m ² GFA - non-residential .	0.6	0.6	0.6	0.6

Table 3.1.2.2 continued on next page

Part 3 - Parking, Loading and Stacking Lane Regulations

Column A		B	C	D	E	F
Line 1.0	TYPE OF USE	UNIT OF MEASUREMENT	PRECINCT 1	PRECINCT 2	PRECINCT 3	PRECINCT 4
Table 3.1.2.2 continued from previous page						
11.0	Contractor Service Shop	spaces per 100 m ² GFA - non-residential	1.1	1.1	1.1	1.1
12.0	Contractor's Yard	spaces per 100 m ² GFA - non-residential	0.6	0.6	0.6	0.6
13.0	Convenience Retail and Service Kiosk	spaces per 100 m ² GFA - non-residential plus a stacking lane where a drive-through is provided ⁽²⁾	3.0	3.0	4.0	5.0
14.0	Day Care	spaces per 100 m ² GFA - non-residential	2.5	2.5	2.5	2.5
15.0	Education and Training Facility	spaces per 100 m ² GFA - non-residential	5.0	5.0	5.0	5.0
16.0	Entertainment Establishment	space per five seats of permanent fixed seating ⁽¹⁾ ;	1.0	1.0	1.0	1.0
		or spaces per 100 m ² GFA - non-residential , whichever is greater.	10.0	10.0	10.0	10.0
17.0	Essential Emergency Service	space per staff on duty with a minimum of 2.0 spaces	1.0	1.0	1.0	1.0
18.0	Financial Institution	spaces per 100 m ² GFA - non-residential plus a stacking lane where a drive-through is provided ⁽²⁾	3.0	3.0	4.0	5.0
19.0	Food Bank	spaces per 100 m ² GFA - non-residential	3.0	3.0	3.0	3.0
20.0	Funeral Establishment	spaces per 100 m ² GFA - non-residential for the area accessible to the public	7.5	7.5	7.5	7.5
21.0	Garden Centre	spaces per 100 m ² GFA - non-residential used for retail sales and display of products and/or office ;	2.0	2.5	2.8	3.0
		and spaces per 100 m ² GFA - non-residential used for warehousing and/or wholesaling.	1.1	1.1	1.1	1.1

Table 3.1.2.2 continued on next page

Part 3 - Parking, Loading and Stacking Lane Regulations

Column A		B	C	D	E	F
Line 1.0	TYPE OF USE	UNIT OF MEASUREMENT	PRECINCT 1	PRECINCT 2	PRECINCT 3	PRECINCT 4
Table 3.1.2.2 continued from previous page						
22.0	Golf Course	spaces per hole	10.0	10.0	10.0	10.0
23.0	Hospital	spaces per 100 m ² GFA - non-residential	2.5	2.5	2.5	2.5
24.0	Library	spaces per 100 m ² GFA - non-residential	3.2	3.2	3.2	3.2
25.0	Manufacturing Facility (Single-Occupancy Building) ⁽⁶⁾	spaces per 100 m ² GFA - non-residential up to 2 325 m² GFA - non-residential;	1.6	1.6	1.6	1.6
		and				
		spaces per 100 m ² GFA - non-residential between 2 325 m² and 9 300 m² GFA - non-residential;	1.1	1.1	1.1	1.1
		and				
		spaces per 100 m ² GFA - non-residential over 9 300 m² GFA - non-residential.	0.6	0.6	0.6	0.6
26.0	Manufacturing Facility (Multiple-Occupancy Mixed Use Building) ⁽⁴⁾	spaces per 100 m ² GFA - non-residential	1.6	1.6	1.6	1.6
		<p>Parking for restaurant, convenience restaurant, banquet hall/conference centre/convention centre, night club, and adult entertainment establishment will be provided in accordance with the applicable regulations contained in Table 3.1.2.2 of this By-law.</p> <p>Parking for individual manufacturing occupancies which exceed a GFA - non-residential of 2 325 m² shall be calculated in accordance with the provisions applicable to manufacturing facility (Single-Occupancy Building).</p> <p>Parking for individual warehouse/ distribution occupancies, and wholesaling occupancies which exceed a GFA - non-residential of 6 975 m² shall be calculated in accordance with the regulations applicable to warehouse/ distribution facilities, wholesaling facilities (Single-Occupancy Building).</p>				
27.0	Marina	spaces per slip or berth	0.6	0.6	0.6	0.6

Table 3.1.2.2 continued on next page

Part 3 - Parking, Loading and Stacking Lane Regulations

Column	A	B	C	D	E	F
Line 1.0	TYPE OF USE	UNIT OF MEASUREMENT	PRECINCT 1	PRECINCT 2	PRECINCT 3	PRECINCT 4
Table 3.1.2.2 continued from previous page						
28.0	Medicinal Product Manufacturing Facility Medicinal Product Manufacturing Facility - Restricted	spaces per 100 m ² GFA - non-residential up to 2 325 m ² GFA - non-residential ;	1.6	1.6	1.6	1.6
		and				
		spaces per 100 m ² GFA - non-residential between 2 325 m ² and 9 300 m ² GFA - non-residential ;	1.1	1.1	1.1	1.1
		and				
		spaces per 100 m ² GFA - non-residential over 9 300 m ² GFA - non residential .	0.6	0.6	0.6	0.6
29.0	Motor Vehicle Body Repair Facility, Motor Vehicle Repair Facility - Commercial Motor Vehicle, Motor Vehicle Repair Facility - Restricted	spaces per 100 m ² GFA - non-residential , of which 50% of the required spaces may be tandem parking spaces	4.3	4.3	4.3	4.3
30.0	Motor Vehicle Sales, Leasing and/or Rental Facility - Commercial Motor Vehicles; Motor Vehicle Sales, Leasing and/or Rental Facility - Restricted	spaces per 100 m ² GFA - non-residential (exclusive of display and storage parking)	4.3	4.3	4.3	4.3
31.0	Motor Vehicle Service Station	spaces per 100 m ² GFA - non-residential	3.0	3.0	4.0	5.0
32.0	Motor Vehicle Wash Facility - Commercial Motor Vehicle, Motor Vehicle Wash Facility - Restricted	spaces per wash bay, of which 2.0 spaces can be located at vacuum stations, plus a stacking lane ⁽²⁾	4.0	4.0	4.0	4.0
33.0	Night Club:					
33.1	Night Club	spaces per 100 m ² GFA - non-residential	25.2	25.2	25.2	25.2
33.2	Night Club (in CC1, CC2, CCO zones)	spaces per 100 m ² GFA - non-residential	9.0	n/a	n/a	n/a

Table 3.1.2.2 continued on next page

Part 3 - Parking, Loading and Stacking Lane Regulations

Column A		B	C	D	E	F
Line 1.0	TYPE OF USE	UNIT OF MEASUREMENT	PRECINCT 1	PRECINCT 2	PRECINCT 3	PRECINCT 4
Table 3.1.2.2 continued from previous page						
34.0	Office:					
34.1	Office ⁽⁶⁾	spaces per 100 m ² GFA - non-residential	2.0	2.5	2.8	3.0
		Where the non-office uses, including medical office , in an office building , are greater than 10% of the total GFA - non-residential of the office building , separate parking will be required for all of such uses in accordance with the regulations contained in Table 3.1.2.2 of this By-law.				
34.2	Medical Office, Medical Office - Restricted	spaces per 100 m ² GFA - non-residential	3.8	4.0	4.5	5.5
35.0	Overnight Accommodation	space per guest room;	0.8	0.8	0.8	0.8
		plus spaces per 100 m ² GFA - non-residential used for public use areas including meeting rooms, conference rooms, recreational facilities, dining and lounge areas and other commercial facilities, but excluding bedrooms, kitchens, laundry rooms, washrooms, lobbies, hallways, elevators, stairways and recreational facilities directly related to the function of the overnight accommodation .	10.0	10.0	10.0	10.0
36.0	Pilot Plant, Prototype Production Facility	spaces per 100 m ² GFA - non-residential up to 2 325 m ² GFA - non-residential ;	1.6	1.6	1.6	1.6
		and spaces per 100 m ² GFA - non-residential between 2 325 m ² and 9 300 m ² GFA - non-residential ;	1.1	1.1	1.1	1.1
		and spaces per 100 m ² GFA - non-residential over 9 300 m ² GFA - non-residential .	0.6	0.6	0.6	0.6

Table 3.1.2.2 continued on next page

Part 3 - Parking, Loading and Stacking Lane Regulations

Column A		B	C	D	E	F
Line 1.0	TYPE OF USE	UNIT OF MEASUREMENT	PRECINCT 1	PRECINCT 2	PRECINCT 3	PRECINCT 4
Table 3.1.2.2 continued from previous page						
37.0	Place of Religious Assembly	space per 4.5 seats for permanent fixed seating ⁽¹⁾ ;	1.0	1.0	1.0	1.0
		plus				
		spaces for any non-fixed moveable seating per 100 m ² GFA - non-residential , all in the worship area ;	27.1	27.1	27.1	27.1
		or				
		spaces for all non-fixed moveable seating per 100 m ² GFA - non-residential , in the worship area ;	27.1	27.1	27.1	27.1
		or				
		spaces per 100 m ² GFA - non-residential , whichever is greater.	10.0	10.0	10.0	10.0
		Where the worship area of a place of religious assembly includes permanent fixed seating or non-fixed moveable seating for clergy, leaders, choirs, or musicians, such seating or area shall be included in the calculation of seating for the purpose of calculating required parking.				
		Where a community/multi-use hall is equal to or less than the gross floor area of the worship area , no additional parking shall be required for that use.				
38.0	Power Generating Facility	space per staff on duty with a minimum of 2.0 spaces	1.0	1.0	1.0	1.0
39.0	Private Club	spaces per 100 m ² GFA - non-residential	4.5	4.5	4.5	4.5
40.0	Recreational Establishment	spaces per 100 m ² GFA - non-residential , except for an arena	4.5	4.5	4.5	4.5
41.0	Repair Establishment	spaces per 100 m ² GFA - non-residential	3.0	3.0	4.0	5.0
42.0	Retail Centre:					
42.1	Retail Centre (Less than or equal to 2 000 m ² GFA - non-residential)	spaces per 100 m ² GFA - non-residential	3.0	3.0	3.5	4.3
		Parking for restaurant and convenience restaurant over 220 m ² GFA - non-residential , place of religious assembly , funeral establishment , overnight accommodation , banquet hall/ conference centre/convention centre and entertainment establishment uses will be provided in accordance with the applicable regulations contained in Table 3.1.2.2 of this By-law.				
42.2	Retail Centre (Greater than 2 000 m ² GFA - non-residential)	spaces per 100 m ² GFA - non-residential	3.8	3.8	4.5	5.4

Table 3.1.2.2 continued on next page

Part 3 - Parking, Loading and Stacking Lane Regulations

Column A		B	C	D	E	F
Line 1.0	TYPE OF USE	UNIT OF MEASUREMENT	PRECINCT 1	PRECINCT 2	PRECINCT 3	PRECINCT 4
Table 3.1.2.2 continued from previous page						
43.0	Retail Store	spaces per 100 m ² GFA - non-residential	3.0	3.0	4.0	5.0
44.0	Restaurants:					
44.1	Convenience Restaurant	spaces per 100 m ² GFA - non-residential				
		Less than or equal to 220 m ² GFA - non-residential	3.0	3.0	4.0	5.0
		Over 220 m ² GFA - non-residential plus a stacking lane ⁽²⁾	6.0	6.0	9.0	9.0
44.2	Restaurant	spaces per 100 m ² GFA - non-residential				
		Less than or equal to 220 m ² GFA - non-residential	3.0	3.0	4.0	5.0
		Over 220 m ² GFA - non-residential	6.0	6.0	9.0	9.0
44.3	Take-out Restaurant	spaces per 100 m ² GFA - non-residential	3.0	3.0	4.0	5.0
45.0	Schools:					
45.1	College, University	spaces per 100 m ² GFA - non-residential used for academic purposes; plus spaces per resident student and/or staff.	1.1	1.1	1.1	1.1
			0.15	0.15	0.15	0.15
45.2	Public/Private School (up to and including Grade 8)	space per 100 m ² GFA - non-residential (excluding portables) plus spaces per portable classroom ⁽³⁾	1.0	1.0	1.0	1.0
			1.0	1.0	1.0	1.0
45.3	Public/Private School (Grade 9 and above)	spaces per 100 m ² GFA - non-residential (excluding portables) plus spaces per portable classroom ⁽³⁾	1.5	1.5	1.5	1.5
			1.0	1.0	1.0	1.0
46.0	Science and Technology Facility	spaces per 100 m ² GFA - non-residential	2.0	2.5	2.8	3.0
47.0	Self Storage Facility	spaces per 100 m ² GFA - non-residential (exclusive of storage parking)	0.25	0.25	0.25	0.25

Table 3.1.2.2 continued on next page

Part 3 - Parking, Loading and Stacking Lane Regulations

Column A		B	C	D	E	F
Line 1.0	TYPE OF USE	UNIT OF MEASUREMENT	PRECINCT 1	PRECINCT 2	PRECINCT 3	PRECINCT 4
Table 3.1.2.2 continued from previous page						
48.0	Service Establishment	spaces per 100 m ² GFA - non-residential	3.0	3.0	4.0	5.0
49.0	Transit Terminal	space per staff on duty with a minimum of 2.0 spaces	1.0	1.0	1.0	1.0
50.0	Truck Terminal	spaces per 100 m ² GFA - non-residential used for office purposes;	2.0	2.5	2.8	3.0
		and/or spaces per 100 m ² GFA - non-residential used for warehouse/distribution facility	1.1	1.1	1.1	1.1
51.0	Utility:					
51.1	Utility Building	space per staff on duty with a minimum of 2.0 spaces	1.0	1.0	1.0	1.0
51.2	Water Treatment Facility	space per staff on duty with a minimum of 2.0 spaces	1.0	1.0	1.0	1.0
51.3	Sewage Treatment Plant	space per staff on duty with a minimum of 2.0 spaces	1.0	1.0	1.0	1.0
51.4	Electric Transformer and Distribution Facility	space per staff on duty with a minimum of 2.0 spaces	1.0	1.0	1.0	1.0
52.0	Vehicle Pound Facility	spaces per 100 m ² GFA - non-residential used for office , with a minimum of 4.0 spaces	2.0	2.5	2.8	3.0
53.0	Veterinary Clinic	spaces per 100 m ² GFA - non-residential	3.0	3.0	3.6	3.6
54.0	Warehouse/ Distribution Facility, Wholesaling Facility (Single-Occupancy Building) ⁽⁶⁾	spaces per 100 m ² GFA - non-residential up to 6 975 m ² GFA - non-residential ;	1.1	1.1	1.1	1.1
		and spaces per 100 m ² GFA - non-residential over 6 975 m ² GFA - non-residential .	0.6	0.6	0.6	0.6

Table 3.1.2.2 continued on next page

Part 3 - Parking, Loading and Stacking Lane Regulations

Column A		B	C	D	E	F
Line 1.0	TYPE OF USE	UNIT OF MEASUREMENT	PRECINCT 1	PRECINCT 2	PRECINCT 3	PRECINCT 4
Table 3.1.2.2 continued from previous page						
55.0	Warehouse/ Distribution Facility, Wholesaling Facility (Multiple-Occupancy Building) ⁽⁵⁾	spaces per 100 m ² GFA - non-residential	1.1	1.1	1.1	1.1
Parking for individual warehouse/distribution occupancies and wholesaling occupancies which exceed a GFA - non-residential of 6 975 m ² shall be calculated in accordance with the regulations applicable to warehouse/distribution facilities, wholesaling facilities (Single-Occupancy Building) .						
56.0	Waste Processing Station	spaces per 100 m ² GFA - non-residential up to 2 325 m ² GFA - non-residential ;	1.6	1.6	1.6	1.6
and		1.1	1.1	1.1	1.1	
spaces per 100 m ² GFA - non-residential between 2 325 m ² and 9 300 m ² GFA - non-residential ;		0.6	0.6	0.6	0.6	
and spaces per 100 m ² GFA - non-residential over 9 300 m ² GFA - non-residential .						
57.0	Waste Transfer Station	spaces per 100 m ² GFA - non-residential up to 6 975 m ² GFA - non-residential ;	1.1	1.1	1.1	1.1
and spaces per 100 m ² GFA - non-residential over 6 975 m ² GFA - non-residential .		0.6	0.6	0.6	0.6	
58.0	Other Non-Residential Uses Not Specified Above	spaces per 100 m ² GFA - non-residential	5.4	5.4	5.4	5.4

- NOTES:** (1) See Sentence 3.1.2.2.1 of this By-law.
(2) See also Subsection 3.1.5 of this By-law.
(3) See also Article 3.1.1.11 of this By-law.
(4) See Sentence 3.1.2.2.2 of this By-law.
(5) See Sentence 3.1.2.2.3 of this By-law.
(6) See Sentence 3.1.2.2.4 of this By-law.

3.1.2.2.1 Where permanent fixed seating in an arena, **entertainment establishment** or **place of religious assembly** is an open-style bench, each 0.5 m of bench is equal to one seat for the purpose of calculating required parking. (0018-2021)

3.1.2.2.2 For the purpose of Article 3.1.2.2 of this By-law, a **manufacturing facility** (multiple-occupancy mixed use **building**) is a **building(s)**, occupied by more than one occupant located on one **lot**, primarily used for **manufacturing, warehouse/distribution** and/or **wholesaling facilities**, but may contain other non-manufacturing, non-warehouse/distribution and/or non-wholesaling facilities. Where the non-manufacturing, non-warehouse/distribution and/or non-wholesaling facilities exceed 50% of the total **gross floor area - non-residential** of the site, separate parking will be required for all **uses** in accordance with the regulations contained in Table 3.1.2.2 of this By-law. (0325-2008), (0379-2009), (0190-2014), (0018-2021)

Part 3 - Parking, Loading and Stacking Lane Regulations

3.1.2.2.3 For the purpose of Article 3.1.2.2 of this By-law, a **warehouse/distribution facility, wholesaling facility** (multiple-occupancy **building**) is a **building(s)** occupied by more than one occupant located on one **lot**, where the primary function of all occupants is warehousing, distribution or wholesaling. (0379-2009), (0018-2021)

3.1.2.2.4 For the purpose of Article 3.1.2.2 of this By-law, where a single occupant **office building** includes a **manufacturing, warehouse/distribution and/or wholesaling facility** component and the **GFA - non-residential** of the **manufacturing, warehouse/distribution and/or wholesaling facility** component is greater than 10% of the total **GFA - non-residential** of the **building**, parking for the **manufacturing, warehouse/distribution and/or wholesaling facility** component shall be calculated in accordance with the applicable **manufacturing, warehouse/distribution and/or wholesaling facility** (single occupancy) regulations contained in Table 3.1.2.2 of this By-law. (0308-2011), (0018-2021)

3.1.2.3 C4 Zone Parking Requirement

For the purpose of Article 3.1.2.2 of this By-law, off-street **parking spaces** for non-residential **uses** in C4 zones shall be provided in accordance with Precinct 1 requirements in Table 3.1.2.2 of this By-law. (0117-2022)

3.1.2.4 Mixed Use Development Shared Parking

A shared parking formula may be used for the calculation of required parking for a mixed use development. A mixed use development means the following: (0379-2009), (0174-2017), (0018-2021), (0117-2022)

- (1) Non-office **uses** in an **office or medical office building** or group of **buildings** on the same **lot**;
- (2) **Office or medical office** space in a **building** or group of **buildings** on the same **lot** primarily occupied by retail **uses**;
- (3) A **building** or group of **buildings** on the same **lot** containing a mix of **office or medical office, commercial uses and dwelling units**;
- (4) Non-residential **uses** in an **apartment**.

Shared parking is to be calculated in compliance with Table 3.1.2.4 - Mixed Use Development Shared Parking Formula.

The initial step in determining required parking for a mixed use development is to calculate the parking requirement for each **use** in the development as if these **uses** were free-standing **buildings**. The parking requirement for each **use** is then multiplied by the percent of the peak period for each time period (i.e. noon), contained in Table 3.1.2.4 - Mixed Use Development Shared Parking Formula. Each column is totalled for weekday and weekend. The highest figure obtained from all time periods shall become the required parking for the mixed use development.

Table 3.1.2.4 - Mixed Use Development Shared Parking Formula ⁽²⁾
(0379-2009), (0111-2019/LPAT Order 2021 March 09), (0018-2021), (0117-2022)

Column A		B	C	D	E
Line 1.0	TYPE OF USE	PERCENTAGE OF PEAK PERIOD (WEEKDAY)			
		Morning	Noon	Afternoon	Evening
1.1	Office/Medical Office/Financial Institution	100	90	95	10
1.2	Retail Centre/ Retail Store/Service Establishment	80	90	90	90
1.3	Restaurant/ Convenience Restaurant/ Take-out Restaurant	20	100	30	100
1.4	Overnight Accommodation	70	70	70	100
1.5	Residential - Resident ⁽¹⁾ Residential - Visitor	90 20	65 20	90 60	100 100

Table 3.1.2.4 continued on next page

Part 3 - Parking, Loading and Stacking Lane Regulations

Column	A	B	C	D	E
Line 1.0	TYPE OF USE	PERCENTAGE OF PEAK PERIOD (WEEKDAY)			
Table 3.1.2.4 continued from previous page					
2.0	TYPE OF USE	PERCENTAGE OF PEAK PERIOD (SATURDAY)			
		Morning	Noon	Afternoon	Evening
2.1	Office/Medical Office/Financial Institution	10	10	10	10
2.2	Retail Centre/ Retail Store/Service Establishment	80	100	100	70
2.3	Restaurant/ Convenience Restaurant/ Take-out Restaurant	20	100	50	100
2.4	Overnight Accommodation	70	70	70	100
2.5	Residential - Resident ⁽¹⁾ Residential - Visitor	90 20	65 20	90 60	100 100

NOTES: (1) See Sentence 3.1.2.4.1 of this By-law.
(2) See Sentence 3.1.1.1.7 of this By-law.

3.1.2.4.1 For the purpose of Article 3.1.2.4 of this By-law, the calculation for residential **uses** shall exclude **retirement buildings** and **long-term care buildings**. (0174-2017), (0111-2019/ LPAT Order 2021 March 09), (0117-2022)

3.1.3 Accessible Parking Spaces

3.1.3.1 Required Number of Accessible Parking Spaces

3.1.3.1A **Accessible parking spaces** for non-residential **uses** shall be provided in compliance with Table 3.1.3.1 - Accessible Parking Regulations. (0144-2016)

3.1.3.1B **Accessible parking spaces** for residential **uses** shall only apply to the total number of visitor **parking spaces** required and shall be provided in compliance with Table 3.1.3.1 - Accessible Parking Regulations. (0144-2016)

Table 3.1.3.1 - Accessible Parking Regulations
(0190-2014), (0144-2016), (0018-2021)

Column	A	B	C
Line 1.0	TOTAL NUMBER OF REQUIRED NON-RESIDENTIAL PARKING SPACES	TOTAL NUMBER OF REQUIRED VISITOR PARKING SPACES	MINIMUM NUMBER OF REQUIRED ACCESSIBLE PARKING SPACES
2.0	1-12	1-12	1.0 space ⁽¹⁾
3.0	13-100	13-100	4% of the total ⁽¹⁾⁽²⁾
4.0	101-200	101-200	1.0 space plus 3% of the total ⁽²⁾
5.0	201-1 000	201-1 000	2.0 spaces plus 2% of the total ⁽²⁾
6.0	1 001 and greater	1 001 and greater	11.0 spaces plus 1% of the total ⁽²⁾

NOTES: (1) See Sentence 3.1.3.1.1 of this By-law.
(2) See Sentence 3.1.3.1.2 of this By-law.
(3) *deleted by 0018-2021.*

3.1.3.1.1 Where only one **accessible parking space** is required, a Type A **accessible parking space** shall be provided. (0018-2021)

3.1.3.1.2 Where more than one **accessible parking space** is required:
(0018-2021)

- (1) if an even number of **accessible parking spaces** is required, an equal number of Type A and Type B **accessible parking spaces** must be provided;
- (2) if an odd number of **accessible parking spaces** is required, an equal number of Type A and Type B **accessible parking spaces** must be provided and the odd space may be a Type B **accessible parking space**.

See Illustration No. 15 - Section 1.3 - Illustrations

3.1.3.1.3 Where a shared parking arrangement is used for the calculation of required visitor/ non-residential parking, the required **accessible parking space** requirement will be calculated on either the visitor component or non-residential component. (0144-2016), (0018-2021)

3.1.3.2 Location of Accessible Parking Spaces

Accessible parking spaces shall be provided and maintained on the same **lot** in proximity to the main entrances to a **building** or **structure**.

3.1.3.3 *deleted by 0117-2022*

3.1.4 Loading Regulations

3.1.4.1 Loading Space Regulations

Loading spaces shall be required for the following **uses**:

- (1) **Retail Store**
- (2) Retail Centre (0379-2009)
- (3) **Office**
- (4) **Medical Office**
- (5) **Overnight Accommodation**
- (6) **Restaurant**
- (7) **Convenience Restaurant**
- (8) **Manufacturing Facility**
- (9) **Warehouse/Distribution Facility**
- (10) **Wholesaling Facility**

3.1.4.2 Required Number of Loading Spaces for Office and/or Medical Office Buildings

Where required for **office** and/or **medical office uses**, **loading spaces** shall be provided in accordance with Table 3.1.4.2 - Required Number of Loading Spaces for Office and/or Medical Office Buildings.

Table 3.1.4.2 - Required Number of Loading Spaces for Office and/or Medical Office Buildings
(0297-2013)

Column A		Column B
Line	GROSS FLOOR AREA - NON-RESIDENTIAL OF BUILDING	MINIMUM NUMBER OF OFF - STREET LOADING SPACES
1.0	Less than or equal to 2 350 m ²	None Required
2.0	Greater than 2 350 m ² but less than or equal to 11 600 m ²	1.0 space
3.0	Greater than 11 600 m ²	1.0 space plus 1.0 additional space for each 9 300 m ² gross floor area - non-residential or portion thereof
4.0		

3.1.4.3 Required Number of Loading Spaces

Where required, **loading spaces** for **uses** other than **office** and/or **medical office uses**, shall be provided in accordance with Table 3.1.4.3 - Required Number of Loading Spaces.

Table 3.1.4.3 - Required Number of Loading Spaces
(0297-2013)

Column A		B
Line 1.0	GROSS FLOOR AREA - NON-RESIDENTIAL OF BUILDING	MINIMUM NUMBER OF OFF-STREET LOADING SPACES
2.0	Less than or equal to 250 m ²	None required
3.0	Greater than 250 m ² but less than or equal to 2 350 m ²	1.0 space
4.0	Greater than 2 350 m ² but less than or equal to 7 500 m ²	2.0 spaces
5.0	Greater than 7 500 m ² but less than or equal to 14 000 m ²	3.0 spaces
6.0	Greater than 14 000 m ²	3.0 spaces plus 1.0 additional space for each 9 300 m ² GFA - non-residential or portion thereof

3.1.4.4 Loading Space Dimensions

Required **loading spaces** shall have an unobstructed rectangular area with a minimum width of 3.5 m and a minimum length of 9.0 m.

3.1.4.5 Required Number of Loading Spaces for Apartment and/or Retirement Buildings

One **loading space** per **apartment** and/or **retirement building** containing a minimum of 30 **dwelling units**, shall be required. (0174-2017)

3.1.5 Stacking Lane Regulations

3.1.5.1 The following regulations shall apply to **uses** that have a **stacking lane** component:

3.1.5.1.1 A **stacking lane** associated with a **convenience restaurant, convenience retail and service kiosk, financial institution, motor vehicle wash facility - commercial motor vehicle** or a **motor vehicle wash facility - restricted** shall be provided in accordance with Table 3.1.5.1.1 - Required Number of Stacking Lane Parking Spaces. (0379-2009)

Table 3.1.5.1.1 - Required Number of Stacking Lane Parking Spaces

Column A		B
Line 1.0	TYPE OF USE	MINIMUM NUMBER OF STACKING LANE TANDEM PARKING SPACES REQUIRED
2.0	Convenience Restaurant	10.0 spaces
3.0	Convenience Retail and Service Kiosk	5.0 spaces
4.0	Financial Institution	5.0 spaces
5.0	Motor Vehicle Wash Facility - Commercial Motor Vehicle (0379-2009)	10.0 spaces per wash bay
6.0	Motor Vehicle Wash Facility - Restricted	10.0 spaces per wash bay

3.1.5.1.2 A **stacking lane** associated with a **convenience restaurant** or **convenience retail and service kiosk** shall be measured from a point located 2.0 m beyond the middle of the drive-through window used for the receipt of goods.

3.1.5.1.3 A **stacking lane** associated with a **financial institution** shall be measured from a point located 2.0 m beyond the middle of the drive-through bank machine.

3.1.5.1.4 A **stacking lane** associated with a **motor vehicle wash facility - commercial motor vehicle** or **motor vehicle wash facility - restricted** shall be measured from the entrance to the wash bay. (0379-2009)

3.1.6 Bicycle Parking Regulations (0118-2022)

3.1.6.1 General Bicycle Parking Regulations

3.1.6.1.1 Notwithstanding Articles 3.1.6.5 and 3.1.6.6 of this By-law, required off-street **bicycle parking spaces** shall only be required for the construction of new **buildings** or portions thereof, effective June 8, 2023.

3.1.6.1.2 Notwithstanding Article 3.1.6.5 of this By-law, **bicycle parking spaces** shall not be required for residential **uses** with less than 20 **dwelling units**.

3.1.6.1.3 Notwithstanding Article 3.1.6.6 of this By-law, **bicycle parking spaces** shall not be required for non-residential **uses** with less than 1 000 m² of **gross floor area - non-residential**.

3.1.6.2 Location of Bicycle Parking

3.1.6.2.1 A **bicycle parking space** shall be located on the same **lot** as the **use** for which it is required.

3.1.6.2.2 Required **bicycle parking spaces** shall not be located in a **dwelling unit**, storage locker or on a **balcony**.

3.1.6.3 Bicycle Parking Space Dimensions

3.1.6.3.1 A **bicycle parking space** is to be provided in either the following sizes:

- (1) minimum length of 1.8 m, a minimum width of 0.6 m, and a minimum vertical clearance from the ground of 1.9 m; or,
- (2) minimum clearance from the wall of 1.2 m, minimum width of 0.6 m, and a minimum vertical clearance from the ground of 1.9 m.

See Illustration No. 18 - Section 1.3 Illustrations

3.1.6.3.2 Notwithstanding Sentence 3.1.6.3.1 of this By-law, a **bicycle parking space - stacked** shall have a minimum vertical clearance of 1.2 m.

3.1.6.4 Bicycle Parking Aisles

3.1.6.4.1 The minimum **bicycle parking aisle** width shall be 1.5 m.

3.1.6.4.2 Access to and from **bicycle parking spaces** shall be provided by unobstructed on-site **driveways** or **bicycle parking aisles**.

3.1.6.5 Required Number of Bicycle Parking Spaces

3.1.6.5.1 Required Number of Bicycle Parking Spaces for Residential Uses

Off-street **bicycle parking spaces** for residential **uses** shall be provided in accordance with Table 3.1.6.5.1 - Required Number of Bicycle Parking Spaces for Residential Uses.

Table 3.1.6.5.1 - Required Number of Bicycle Parking Spaces for Residential Uses

Column A		B	C
Line 1.0	TYPE OF USE	BICYCLE PARKING - CLASS A	BICYCLE PARKING - CLASS B
2.0	Apartment and stacked townhouse without exclusive garages	0.6 spaces per unit	The greater of 0.05 spaces per unit or 6.0 spaces
3.0	Apartment and stacked townhouse without exclusive garages (within CC1 to CC4 and CCO zones)	0.8 spaces per unit	The greater of 0.1 spaces per unit or 6.0 spaces
4.0	Long-Term Care Building	0.2 spaces per 100 m ² GFA - residential	0.2 spaces per 100 m ² GFA - residential
5.0	Long-Term Care Building (within CC1 to CC4 and CCO zones)	0.3 spaces per 100 m ² GFA - residential	0.3 spaces per 100 m ² GFA - residential
6.0	Retirement Building	0.3 spaces per unit	The greater of 0.03 spaces per unit or 6.0 spaces
7.0	Retirement Building (within CC1 to CC4 and CCO zones)	0.4 spaces per unit	The greater of 0.05 spaces per unit or 6.0 spaces

3.1.6.6 Required Number of Bicycle Parking Spaces for Non-Residential Uses

Off-street **bicycle parking spaces** for non-residential **uses** shall be provided in accordance with Table 3.1.6.6 - Required Number of Bicycle Parking Spaces for Non-Residential Uses.

Table 3.1.6.6 - Required Number of Bicycle Parking Spaces for Non-Residential Uses

Column A		B	C
Line 1.0	TYPE OF USE	BICYCLE PARKING - CLASS A	BICYCLE PARKING - CLASS B
2.0	Active Recreational Use, Community Centre, Hospital, Library, Place of Religious Assembly, and Recreational Establishment	0.1 spaces per 100 m ² GFA - non-residential	0.1 spaces per 100 m ² GFA - non-residential
3.0	Active Recreational Use, Community Centre, Hospital, Library, Place of Religious Assembly, and Recreational Establishment (within CC1 to CC4 and CCO zones)	0.3 spaces per 100 m ² GFA - non-residential	0.3 spaces per 100 m ² GFA - non-residential

Table 3.1.6.6 continued on next page

Part 3 - Parking, Loading and Stacking Lane Regulations

Column A		B	C
Line 1.0	TYPE OF USE	BICYCLE PARKING - CLASS A	BICYCLE PARKING - CLASS B
Table 3.1.6.6 continued from previous page			
4.0	College, University	1.0 spaces per 100 m ² GFA - non-residential	1.2 spaces per 100 m ² GFA - non-residential
5.0	College, University (within CC1 to CC4 and CCO zones)	1.0 spaces per 100 m ² GFA - non-residential	1.2 spaces per 100 m ² GFA - non-residential
6.0	Contractor's Yard, Essential Emergency Service, Power Generating Facility , Self Storage Facility, Utilities (Electric Transformer and Distribution Facility, Sewage Treatment Plant, Utility Building, Water Treatment Facility) and Waste Transfer Station	n/a	2.0 spaces
7.0	Education and Training Facility, Financial Institution, Manufacturing Facility, Science and Technology Facility, Warehouse/Distribution Facility, and Wholesaling Facility	0.1 spaces per 100 m ² GFA - non-residential	2.0 spaces
8.0	Education and Training Facility, Financial Institution, Manufacturing Facility, Science and Technology Facility, Warehouse/Distribution Facility, and Wholesaling Facility (within CC1 to CC4 and CCO zones)	0.15 spaces per 100 m ² GFA - non-residential	0.15 spaces per 100 m ² GFA - non-residential
9.0	Entertainment Establishment, Restaurant, Convenience Restaurant, Take-out Restaurant Retail Centre, Retail Store, and Service Establishment	0.15 spaces per 100 m ² GFA - non-residential	0.2 spaces per 100 m ² GFA - non-residential
10.0	Entertainment Establishment, Restaurant, Convenience Restaurant, Take-out Restaurant, Retail Centre, Retail Store, and Service Establishment (within CC1 to CC4 and CCO zones)	0.15 spaces per 100 m ² GFA - non-residential	0.3 spaces per 100 m ² GFA - non-residential
11.0	Medical Office and Medical Office - Restricted	0.1 spaces per 100 m ² GFA - non-residential	0.1 spaces per 100 m ² GFA - non-residential
12.0	Medical Office and Medical Office - Restricted (within CC1 to CC4 and CCO zones)	0.15 spaces per 100 m ² GFA - non-residential	0.2 spaces per 100 m ² GFA - non-residential
13.0	Office	0.1 spaces per 100 m ² GFA - non-residential	0.1 spaces per 100 m ² GFA - non-residential
14.0	Office (within CC1 to CC4 and CCO zones)	0.2 spaces per 100 m ² GFA - non-residential	0.15 spaces per 100 m ² GFA - non-residential
15.0	Public/Private School	0.1 spaces per 100 m ² GFA - non-residential	0.4 spaces per 100 m ² GFA - non-residential
16.0	Public/Private School (within CC1 to CC4 and CCO zones)	0.1 spaces per 100 m ² GFA - non-residential	0.4 spaces per 100 m ² GFA - non-residential

Table 3.1.6.6 continued on next page

Part 3 - Parking, Loading and Stacking Lane Regulations

Column A		B	C
Line 1.0	TYPE OF USE	BICYCLE PARKING - CLASS A	BICYCLE PARKING - CLASS B
Table 3.1.6.6 continued from previous page			
17.0	All other non-residential uses	0.05 spaces per 100 m ² GFA - non-residential	0.1 spaces per 100 m ² GFA - non-residential
18.0	All other non-residential uses (within CC1 to CC4 and CCO zones)	0.05 spaces per 100 m ² GFA - non-residential	0.1 spaces per 100 m ² GFA - non-residential

Official Plan Amendment indicated that, given the growth pressures in Uptown Node, road improvements alone will not be enough to alleviate expected traffic congestion by 2041. By reducing parking rates it is anticipated that the modal split towards non-auto modes of transportation, including transit, will be encouraged.

- **Refinement to Precinct 3:** It is proposed to include the area west of Port Credit Community Node and areas adjacent to the 403 BRT corridor, west of the Downtown Core, in Precinct 3.

Figure 1: Map of Proposed Parking Precincts, March 2022

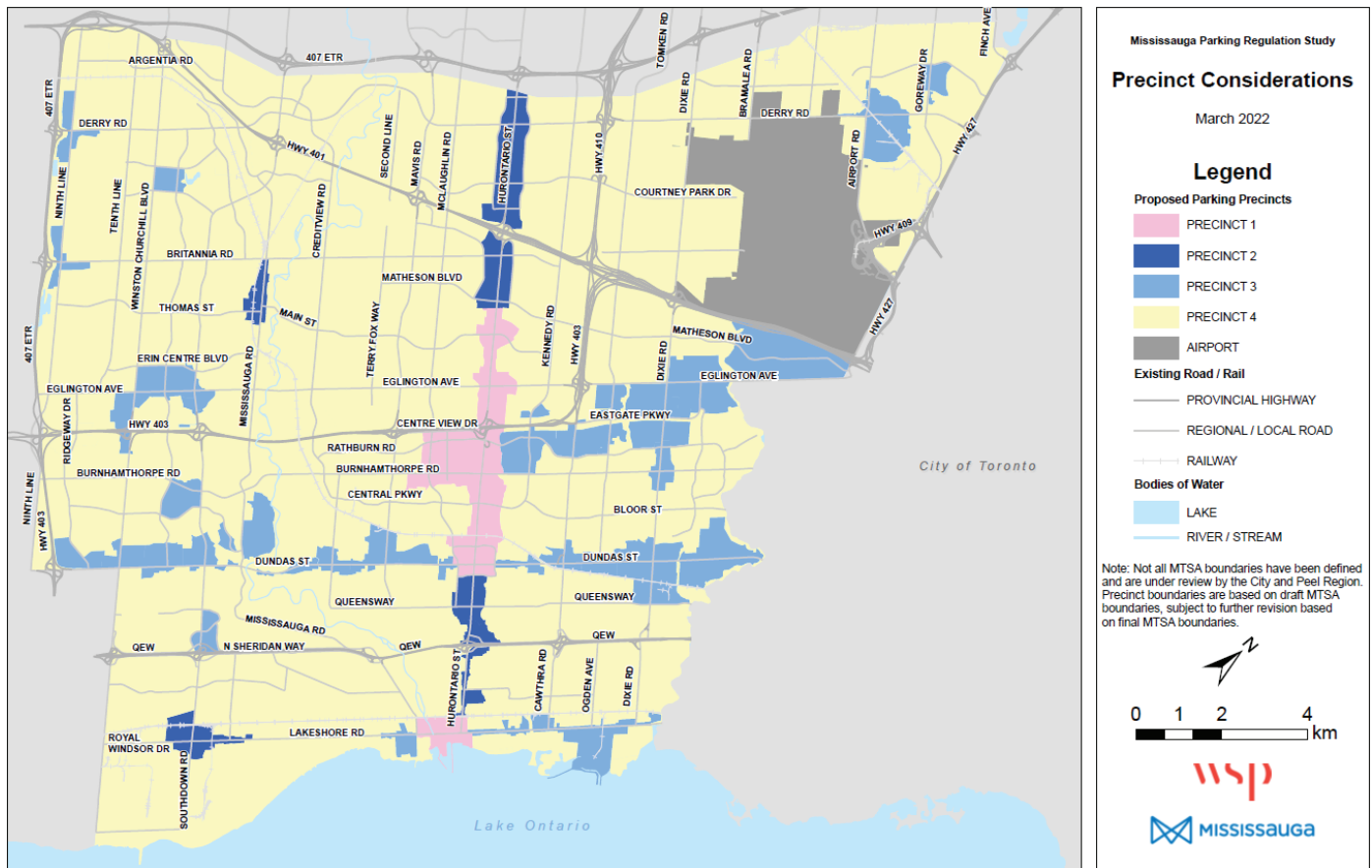

b) Changes to Residential Parking Rates

The following highlights any changes since the December 6, 2021 PDC meeting:

- **Maintain existing visitor parking requirements:** Staff reviewed existing developments and confirmed a high number of parking complaints regarding inadequate visitor parking.
- **Transitional Housing:** It is proposed to lower the parking requirement for transitional or emergency housing given most of the occupants typically do not have a car.

Column	A	B	<u>C</u>	<u>D</u>	<u>E</u>	<u>F</u>
Line	TYPE OF USE	MINIMUM OFF-STREET PARKING REGULATION UNIT OF MEASUREMENT	<u>PRECINCT 1</u>	<u>PRECINCT 2</u>	<u>PRECINCT 3</u>	<u>PRECINCT 4</u>
2.0	Condominium Apartment (0207-2008), (0174-2017), (0179-2018),	1.00 resident space per studio unit 1.25 resident spaces per one bedroom unit 1.40 resident spaces per two bedroom unit 1.75 resident spaces per three bedroom unit <u>resident spaces per unit</u> 0.20 visitor spaces per unit	<u>0.8</u> 0.20	<u>0.9</u> 0.20	<u>1.0</u> 0.20	<u>1.1</u> 0.20
3.0	Rental Apartment (0207-2008), (0174-2017), (0179-2018),	1.00 resident space per studio unit 1.18 resident spaces per one bedroom unit 1.36 resident spaces per two bedroom unit 1.50 resident spaces per three bedroom unit <u>resident spaces per unit</u> 0.20 visitor spaces per unit	<u>0.8</u> 0.20	<u>0.8</u> 0.20	<u>0.9</u> 0.20	<u>1.0</u> 0.20
<u>4.0</u>	<u>Public Authority Dwelling Unit in a Rental Apartment</u>	<u>resident spaces per unit</u> <u>visitor spaces per unit</u>	<u>0.4</u> 0.20	<u>0.6</u> 0.20	<u>0.65</u> 0.20	<u>0.7</u> 0.20
<u>5.0</u> 4.0	Apartment (within CC1 to CC4 zones) (0207-2008), (0174-2017)	1.0 resident spaces per unit 0.15 visitor spaces per unit ⁽¹⁾	<u>0.8</u> 0.15			

Column A	B	<u>C</u>	<u>D</u>	<u>E</u>	<u>F</u>	
Line 1.0	TYPE OF USE	<u>MINIMUM OFF-STREET PARKING REGULATION UNIT OF MEASUREMENT</u>	<u>PRECINCT 1</u>	<u>PRECINCT 2</u>	<u>PRECINCT 3</u>	<u>PRECINCT 4</u>
		<p>For the visitor component, a shared parking arrangement may be used for the calculation of required visitor/non-residential parking in accordance with the following: the greater of 0.15 visitor spaces per unit ⁽¹⁾⁽²⁾ or Parking required for all non-residential uses, located in the same building or on the same lot as the residential use, except banquet hall/conference centre/convention centre, entertainment establishment, overnight accommodation, place of religious assembly, recreational establishment and restaurant. ⁽¹⁾⁽²⁾ Parking for banquet hall/conference centre/convention centre, entertainment establishment, overnight accommodation, place of religious assembly, recreational establishment and restaurant shall not be included in the above shared parking arrangement and shall be provided in accordance with applicable regulations contained in Table 3.1.2.2 of this By-law.</p>				
5.0 <u>6.0</u>	Detached Dwelling, Linked Dwelling, Semi-Detached, Street Townhouse (0297-2013), (0174-2017), (0181-2018/LPAT Order 2019 February 15)	2.0 spaces per unit	2.0	2.0	2.0	2.0
6.0 <u>7.0</u>	Condominium Detached Dwelling, Condominium Semi-Detached, Condominium Townhouse, Detached Dwelling on a CEC - Road, Semi-Detached on a CEC - Road, Townhouse on a CEC - Road (0174-2017), (0181-2018/LPAT Order 2019 February 15)	2.0 resident spaces per unit 0.25 visitor spaces per unit	2.0 0.25	2.0 0.25	2.0 0.25	2.0 0.25
7.0 <u>8.0</u>	Duplex, Triplex (0174-2017)	1.25 spaces per unit	1.25	1.25	1.25	1.25
8.0 <u>9.0</u>	Dwelling units located above a commercial development with a maximum height of three storeys	1.25 spaces per unit	<u>1.0</u>	<u>1.0</u>	<u>1.0</u>	<u>1.0</u>
9.0 <u>10.0</u>	Group Home	2.0 spaces	2.0	2.0	2.0	2.0

Column	A	B	C	D	E	F
Line 1.0	TYPE OF USE	MINIMUM OFF-STREET PARKING REGULATION UNIT OF MEASUREMENT	<u>PRECINCT 1</u>	<u>PRECINCT 2</u>	<u>PRECINCT 3</u>	<u>PRECINCT 4</u>
11.0 10.0	Condominium Back to Back and Stacked Townhouse <u>Without exclusive use garage and driveway</u> (0179-2018), (0181-2018/LPAT Order 2019 February 15) (0XXX-2022)	Without exclusive use garage and driveway: 1.10 resident spaces per studio/one-bedroom unit 1.5 resident spaces per two bedroom unit 1.75 resident spaces per three bedroom unit 2.0 resident spaces per four bedroom unit <u>resident spaces per unit</u> 0.25 visitor spaces per unit	<u>1.0</u> 0.25	<u>1.1</u> 0.25	<u>1.3</u> 0.25	<u>1.5</u> 0.25
<u>12.0</u>	<u>Back to Back and Stacked Townhouse</u> <u>With exclusive use garage and driveway</u>	With exclusive use garage and driveway: 2.0 resident spaces per unit 0.25 visitor spaces per unit	2.0 0.25	2.0 0.25	2.0 0.25	2.0 0.25
<u>13.0</u> 11.0	<u>Rental Back to Back and Stacked Townhouse, Rental Townhouse</u> (0179-2018), (0181-2018/LPAT Order 2019 February 15)	Without exclusive use garage and driveway: 1.10 resident spaces per studio/one bedroom unit 1.25 resident spaces per two bedroom unit 1.41 resident spaces per three bedroom unit 1.95 resident spaces per four bedroom unit 0.25 visitor spaces per unit With exclusive use garage and driveway: 2.0 resident spaces per unit 0.25 visitor spaces per unit				
<u>14.0</u> 12.0	<u>Long-Term Care Building</u> (0174-2017)	0.33 spaces per bed	0.33	0.33	0.33	0.33
13.0	<i>Deleted by (0111-2019)</i>					
14.0	<u>Retirement Building</u> (0174-2017)	0.50 spaces per unit	0.50	0.50	0.50	0.50
<u>15.0</u>	<u>Public Authority Dwelling Unit in a Retirement Building</u>	spaces per unit	<u>0.25</u>	<u>0.35</u>	<u>0.35</u>	<u>0.35</u>
<u>16.0</u>	<u>Transitional Housing</u>	spaces per unit or sleeping rooms, <u>whichever is greater</u>	<u>0.1</u>	<u>0.1</u>	<u>0.1</u>	<u>0.1</u>
<u>17.0</u> 15.0	All other housing forms not identified above with more than two dwelling units	2.0 resident spaces per unit 0.25 visitor spaces per unit	2.0 0.25	2.0 0.25	2.0 0.25	2.0 0.25

NOTES: (1) See Sentence 3.1.2.1.1 of this By-law.
(2) See Sentence 3.1.1.1.7 of this By-law.

- 3.1.2.1.2 Visitor **parking spaces** shall not be required for an **apartment** legally **existing** within CC1 to CC4 zones for which a building permit has been issued on or before May 29, 2009. (0207-2008), (0174-2017)

3.1.2.1.3 Shared Arrangement for Residential Visitor and Non-Residential Parking Component

For the purpose of Article 3.1.2.1 of this By-law, a shared parking arrangement may be used for the calculation of required residential visitor/ non-residential parking in accordance with the following:

the greater of

(1) visitor spaces per unit in accordance with applicable regulations contained in Table 3.1.2.1 of this By-law

or

(2) Parking required for all non-residential **uses**, located in the same **building** or on the same **lot** as the residential **use**, except **banquet hall/conference centre/convention centre, entertainment establishment, overnight accommodation, place of religious assembly, recreational establishment and restaurant over 220 m² GFA - non-residential**.

Parking for **banquet hall/conference centre/convention centre, entertainment establishment, overnight accommodation, place of religious assembly, recreational establishment and restaurant over 220 m² GFA - non-residential** shall not be included in the above shared parking arrangement and shall be provided in accordance with applicable regulations contained in Table 3.1.2.2 of this By-law.

3.1.2.2 Required Number of Parking Spaces for Non-Residential Uses

Off-street **parking spaces** for non-residential **uses** shall be provided in accordance with Table 3.1.2.2. –Required Number of Off-Street Parking Spaces for Non-Residential Uses.

Table 3.1.2.2 - Required Number of Off-Street Parking Spaces for Non-Residential Uses

(note to reviewers: only categories in red underline have revised parking requirements; existing parking requirement in black font will remain across all precincts)

Column	A	B	<u>C</u>	<u>D</u>	<u>E</u>	<u>F</u>
Line 1.0	TYPE OF USE	<u>MINIMUM OFF-STREET PARKING REGULATION UNIT OF MEASUREMENT</u>	<u>PRECINCT 1</u>	<u>PRECINCT 2</u>	<u>PRECINCT 3</u>	<u>PRECINCT 4</u>
2.0	Active Recreational Use	4.5 spaces per 100 m ² GFA - non-residential, except for an arena or a marina	4.5	4.5	4.5	4.5
3.0	Adult Entertainment Establishment	16.3 spaces per 100 m ² GFA - non-residential	16.3	16.3	16.3	16.3
4.0	Animal Services:					
4.1	Animal Boarding Establishment	3.6 spaces per 100 m ² GFA - non-residential	<u>3.0</u>	<u>3.0</u>	3.6	3.6
4.2	Animal Care Establishment	5.4 spaces per 100 m ² GFA - non-residential	<u>3.0</u>	<u>3.0</u>	<u>4.0</u>	<u>5.0</u>
4.3	Animal Care Establishment (in a C4 zone)	4.0 spaces per 100 m² GFA - non-residential				
5.0	Arena	1.0 space per 4 seats of permanent fixed seating ⁽¹⁾	1.0	1.0	1.0	1.0
6.0	Art Gallery, Museum	3.6 spaces per 100 m ² GFA - non-residential	<u>3.0</u>	<u>3.0</u>	3.6	3.6
7.0	Banquet Hall/Conference Centre/ Convention Centre	10.8 spaces per 100 m ² GFA - non-residential	10.8	10.8	10.8	10.8
8.0	Commercial School	5.0 spaces per 100 m ² GFA - non-residential	5.0	5.0	5.0	5.0
9.0	Community Centre	4.5 spaces per 100 m ² GFA - non-residential, except for an arena	4.5	4.5	4.5	4.5
10.0	Composting Facility	1.6 spaces per 100 m ² GFA - non-residential up to 2 325 m ² GFA - non-residential; and 1.1 spaces per 100 m ² GFA - non-residential between 2 325 m ² and 9 300 m ² GFA - non-residential; and 0.6 spaces per 100 m ² GFA - non-residential over 9 300 m ² GFA - non-residential	1.6 and 1.1 and 0.6	1.6 and 1.1 and 0.6	1.6 and 1.1 and 0.6	1.6 and 1.1 and 0.6
10A.0 <u>11.0</u>	Contractor Service Shop (0190-2014)	1.1 spaces per 100 m ² GFA - non-residential	1.1	1.1	1.1	1.1
10B.0 <u>12.0</u>	Contractor's Yard (0190-2014)	spaces per 100 m ² GFA - non-residential	0.6	0.6	0.6	0.6

Column	A	B	<u>C</u>	<u>D</u>	<u>E</u>	<u>F</u>
Line 1.0	TYPE OF USE	MINIMUM OFF-STREET PARKING REGULATION <u>UNIT OF MEASUREMENT</u>	<u>PRECINCT 1</u>	<u>PRECINCT 2</u>	<u>PRECINCT 3</u>	<u>PRECINCT 4</u>
11.0 <u>13.0</u>	Convenience Retail and Service Kiosk (0018-2015)	5.4 spaces per 100 m ² GFA - non-residential plus a stacking lane where a drive-through is provided ⁽²⁾	<u>3.0</u>	<u>3.0</u>	<u>4.0</u>	<u>5.0</u>
12.0 <u>14.0</u>	Day Care	2.5 spaces per 100m ² GFA - non-residential	2.5	2.5	2.5	2.5
13.0 <u>15.0</u>	Education and Training Facility	5.0 spaces per 100 m ² GFA - non-residential	5.0	5.0	5.0	5.0
14.0 <u>16.0</u>	Entertainment Establishment	1.0 space per 5 seats of permanent fixed seating ⁽¹⁾ or 10.0 spaces per 100 m ² GFA - non-residential, whichever is greater	1.0 or 10.0	1.0 or 10.0	1.0 or 10.0	1.0 or 10.0
15.0 <u>17.0</u>	Essential Emergency Service	1.0 space per staff on duty with a minimum of 2.0 spaces	1.0	1.0	1.0	1.0
16.0 <u>18.0</u>	Financial Institution (0018-2015)	5.5 spaces per 100 m ² GFA - non-residential plus a stacking lane where a drive-through is provided ⁽²⁾	<u>3.0</u>	<u>3.0</u>	<u>4.0</u>	<u>5.0</u>
16A.0 <u>19.0</u>	Food Bank (0325-2008)	3.0 spaces per 100 m ² GFA - non-residential	3.0	3.0	3.0	3.0
17.0 <u>20.0</u>	Funeral Establishment	7.5 spaces per 100 m ² GFA - non-residential for the area accessible to the public	7.5	7.5	7.5	7.5
18.0 <u>21.0</u>	Garden Centre	3.2 spaces per 100 m ² GFA - non-residential used for retail sales and display of products and/or office ; and spaces per 100 m ² GFA - non-residential used for warehousing and/or wholesaling	<u>2.0</u> and 1.1	<u>2.5</u> and 1.1	<u>2.8</u> and 1.1	<u>3.0</u> and 1.1
19.0 <u>22.0</u>	Golf Course	10.0 spaces per hole	10.0	10.0	10.0	10.0
20.0	<i>deleted by 0212-2015</i>					
21.0 <u>23.0</u>	Hospital	2.5 spaces per 100 m ² GFA - non-residential	2.5	2.5	2.5	2.5
22.0 <u>24.0</u>	Library	3.2 spaces per 100 m ² GFA - non-residential	3.2	3.2	3.2	3.2

Column	A	B	<u>C</u>	<u>D</u>	<u>E</u>	<u>F</u>
Line 1.0	TYPE OF USE	MINIMUM OFF-STREET PARKING REGULATION <u>UNIT OF MEASUREMENT</u>	<u>PRECINCT 1</u>	<u>PRECINCT 2</u>	<u>PRECINCT 3</u>	<u>PRECINCT 4</u>
23.0 <u>25.0</u>	Manufacturing Facility (Single-Occupancy Building) ⁽⁶⁾ (0308-2011)	1.6 spaces per 100 m ² GFA - non-residential up to 2 325 m ² GFA - non-residential ; and 1.1 spaces per 100 m ² GFA - non-residential between 2 325 m ² and 9 300 m ² GFA - non-residential ; and 0.6 spaces per 100 m ² GFA - non-residential over 9 300 m ² GFA - non-residential	1.6 and 1.1 and 0.6	1.6 and 1.1 and 0.6	1.6 and 1.1 and 0.6	1.6 and 1.1 and 0.6
24.0 <u>26.0</u>	Manufacturing Facility (Multiple-Occupancy Mixed Use Building) ⁽⁴⁾	1.6 spaces per 100 m ² GFA - non-residential Parking for restaurant, convenience restaurant, banquet hall/conference centre/convention centre, night club, and adult entertainment establishment will be provided in accordance with the applicable regulations contained in Table 3.1.2.2 of this By-law. Parking for individual manufacturing occupancies which exceed a GFA - non-residential of 2 325 m ² shall be calculated in accordance with the provisions applicable to manufacturing facility (Single-Occupancy Building). Parking for individual warehouse/distribution occupancies, and wholesaling occupancies which exceed a GFA - non-residential of 6 975 m ² shall be calculated in accordance with the regulations applicable to warehouse/distribution facilities, wholesaling facilities (Single-Occupancy Building).	1.6	1.6	1.6	1.6
25.0 <u>27.0</u>	Marina	0.6 spaces per slip or berth	0.6	0.6	0.6	0.6

Column	A	B	<u>C</u>	<u>D</u>	<u>E</u>	<u>F</u>
Line 1.0	TYPE OF USE	MINIMUM OFF-STREET PARKING REGULATION <u>UNIT OF MEASUREMENT</u>	<u>PRECINCT 1</u>	<u>PRECINCT 2</u>	<u>PRECINCT 3</u>	<u>PRECINCT 4</u>
25A.0 <u>28.0</u>	Medicinal Product Manufacturing Facility (0055-2015) Medicinal Product Manufacturing Facility - Restricted (0055-2015)	1.6 spaces per 100 m² GFA - non-residential up to 2 325 m² GFA - non-residential; and 1.1 spaces per 100 m² GFA - non-residential between 2 325 m² and 9 300 m² GFA - non-residential; and 0.6 spaces per 100 m² GFA - non-residential over 9 300 m² GFA - non-residential	1.6 and 1.1 and 0.6	1.6 and 1.1 and 0.6	1.6 and 1.1 and 0.6	1.6 and 1.1 and 0.6
25B.0	Medicinal Product Manufacturing Facility - Restricted (0055-2015)	1.6 spaces per 100 m² GFA - non-residential up to 2 325 m² GFA - non-residential; and 1.1 spaces per 100 m² GFA - non-residential between 2 325 m² and 9 300 m² GFA - non-residential; and 0.6 spaces per 100 m² GFA - non-residential over 9 300 m² GFA - non-residential	1.6 and 1.1 and 0.6	1.6 and 1.1 and 0.6	1.6 and 1.1 and 0.6	1.6 and 1.1 and 0.6
26.0 <u>29.0</u>	Motor Vehicle Body Repair Facility, Motor Vehicle Repair Facility - Commercial Motor Vehicle, Motor Vehicle Repair Facility - Restricted (0379-2009)	4.3 spaces per 100 m² GFA - non-residential, of which 50% of the required spaces may be tandem parking spaces	4.3	4.3	4.3	4.3
27.0 <u>30.0</u>	Motor Vehicle Sales, Leasing and/or Rental Facility - Commercial Motor Vehicles; Motor Vehicle Sales, Leasing and/or Rental Facility - Restricted	4.3 spaces per 100 m² GFA - non-residential (exclusive of display and storage parking)	4.3	4.3	4.3	4.3
28.0 <u>31.0</u>	Motor Vehicle Service Station	5.4 spaces per 100 m² GFA - non-residential	<u>3.0</u>	<u>3.0</u>	<u>4.0</u>	<u>5.0</u>
29.0 <u>32.0</u>	Motor Vehicle Wash Facility - Commercial Motor Vehicle, Motor Vehicle Wash Facility - Restricted (0379-2009)	4.0 spaces per wash bay, of which 2.0 spaces can be located at vacuum stations, plus a stacking lane ⁽²⁾	4.0	4.0	4.0	4.0

Column	A	B	C	D	E	F
Line 1.0	TYPE OF USE	MINIMUM OFF-STREET PARKING REGULATION UNIT OF MEASUREMENT	PRECINCT 1	PRECINCT 2	PRECINCT 3	PRECINCT 4
<u>33.0</u>	<u>Night Club</u>					
30.1 <u>33.1</u>	Night Club	25.2 spaces per 100 m ² GFA - non-residential	25.2	25.2	25.2	25.2
30.2 <u>33.2</u>	Night Club (in CC1, CC2, CCO zones)	9.0 spaces per 100 m ² GFA - non-residential	9.0			
31.0 <u>34.0</u>	Office:					
31.1 <u>34.1</u>	Office ⁽⁶⁾ (0308-2011) (0111-2019)	3.2 spaces per 100 m ² GFA - non-residential Where the non-office uses, including medical office, in an office building, are greater than 10% of the total GFA - non-residential of the office building, separate parking will be required for all of such uses in accordance with the regulations contained in Table 3.1.2.2 of this By-law	<u>2.0</u>	<u>2.5</u>	<u>2.8</u>	<u>3.0</u>
31.2 <u>34.2</u>	Medical Office, <u>Medical Office-Restricted</u>	6.5 spaces per 100 m ² GFA - non-residential	<u>3.8</u>	<u>4.0</u>	<u>4.5</u>	<u>5.5</u>
31.3	Medical Office-Restricted	6.5 spaces per 100 m ² GFA - non-residential				
31.4	deleted by 0111-2019					
32.0 <u>35.0</u>	Overnight Accommodation (0379-2009)	0.8 space per guest room; plus 10.0 spaces per 100 m ² GFA - non-residential used for public use areas including meeting rooms, conference rooms, recreational facilities, dining and lounge areas and other commercial facilities, but excluding bedrooms, kitchens, laundry rooms, washrooms, lobbies, hallways, elevators, stairways and recreational facilities directly related to the function of the overnight accommodation	0.8 plus 10.0	0.8 plus 10.0	0.8 plus 10.0	0.8 plus 10.0
34.0 <u>36.0</u>	Pilot Plant, Prototype Production Facility (0325-2008)	1.6 spaces per 100 m ² GFA - non-residential up to 2 325 m ² GFA - non-residential; and 1.1 spaces per 100 m ² GFA - non-residential between 2 325 m ² and 9 300 m ² GFA - non-residential; and 0.6 spaces per 100 m ² GFA - non-residential over 9 300 m ² GFA - non-residential	1.6 and 1.1 and 0.6	1.6 and 1.1 and 0.6	1.6 and 1.1 and 0.6	1.6 and 1.1 and 0.6

Column	A	B	<u>C</u>	<u>D</u>	<u>E</u>	<u>F</u>
Line 1.0	TYPE OF USE	MINIMUM OFF-STREET PARKING REGULATION <u>UNIT OF MEASUREMENT</u>	<u>PRECINCT 1</u>	<u>PRECINCT 2</u>	<u>PRECINCT 3</u>	<u>PRECINCT 4</u>
35.0 <u>37.0</u>	Place of Religious Assembly	1.0 space per 4.5 seats for permanent fixed seating ⁽¹⁾ ; plus 27.1 spaces for any non-fixed moveable seating per 100 m ² GFA - non-residential, all in the worship area or 27.1 spaces for all non-fixed moveable seating per 100 m ² GFA - non-residential, in the worship area or 10.0 spaces per 100 m ² GFA - non-residential, whichever is greater Where the worship area of a place of religious assembly includes permanent fixed seating or non-fixed moveable seating for clergy, leaders, choirs, or musicians, such seating or area shall be included in the calculation of seating for the purpose of calculating required parking. Where a community/multi use hall is equal to or less than the gross floor area of the worship area , no additional parking shall be required for that use.	1.0 plus 27.1 or 27.1 or 10.0	1.0 plus 27.1 or 27.1 or 10.0	1.0 plus 27.1 or 27.1 or 10.0	1.0 plus 27.1 or 27.1 or 10.0
36.0 <u>38.0</u>	Power Generating Facility	1.0 space per staff on duty with a minimum of 2.0 spaces	1.0	1.0	1.0	1.0
37.0 <u>39.0</u>	Private Club	4.5 spaces per 100 m ² GFA - non-residential	4.5	4.5	4.5	4.5
38.0 <u>40.0</u>	Recreational Establishment	4.5 spaces per 100 m ² GFA - non-residential, except for an arena	4.5	4.5	4.5	4.5
39.0 <u>41.0</u>	Repair Establishment:	spaces per 100 m² GFA - non-residential	<u>3.0</u>	<u>3.0</u>	<u>4.0</u>	<u>5.0</u>
39.1	Repair Establishment	5.4 spaces per 100 m² GFA - non-residential				
39.2	Repair Establishment (in a C4 zone)	4.0 spaces per 100 m² GFA - non-residential				
40.0 <u>42.0</u>	Retail Centre:					

Column	A	B	<u>C</u>	<u>D</u>	<u>E</u>	<u>F</u>
Line 1.0	TYPE OF USE	MINIMUM OFF-STREET PARKING REGULATION <u>UNIT OF MEASUREMENT</u>	<u>PRECINCT 1</u>	<u>PRECINCT 2</u>	<u>PRECINCT 3</u>	<u>PRECINCT 4</u>
40.1 <u>42.0</u>	Retail Centre (Less than or equal to 2 000 m ² GFA - non-residential) (0325-2008), (0379-2009)	4.3 spaces per 100 m ² GFA - non-residential Parking for restaurant <u>and</u> convenience restaurant <u>over</u> <u>220 m² GFA - non-residential</u> , place of religious assembly, funeral establishment, overnight accommodation, banquet hall/conference centre/convention centre and entertainment establishment uses will be provided in accordance with the applicable regulations contained in Table 3.1.2.2 of this By-law	<u>3.0</u>	<u>3.0</u>	<u>3.5</u>	4.3
40.2 <u>42.2</u>	Retail Centre (Greater than 2 000 m ² GFA - non-residential) (0379-2009)	5.4 spaces per 100 m ² GFA - non-residential	<u>3.8</u>	<u>3.8</u>	<u>4.5</u>	5.4
40.3	CC1 - Retail Core Commercial (lands bounded by City Centre Drive, Duke of York Boulevard and Rathburn Road West)	4.57 spaces per 100 m ² GFA - non-residential				
41.0 <u>43.0</u>	Retail Store:	spaces per 100 m ² GFA - non-residential	<u>3.0</u>	<u>3.0</u>	<u>4.0</u>	<u>5.0</u>
41.1	Retail Store	5.4 spaces per 100 m ² GFA - non-residential				
41.2	Retail Store (in a C4 zone)	4.0 spaces per 100 m ² GFA - non-residential				
41.3	Retail Store (in a CC2 to CC4 zones) (0207-2008)	4.3 spaces per 100 m ² GFA - non-residential				
42.0 <u>44.0</u>	Restaurants:					
42.1 <u>44.1</u>	Convenience Restaurant (0212-2015)	16.0 spaces per 100 m ² GFA - non-residential <u>Up to 220 m² GFA - non-residential</u> <u>Over 220 m² GFA - non-residential</u> plus a stacking lane ⁽²⁾	<u>3.0</u> <u>6.0</u>	<u>3.0</u> <u>6.0</u>	<u>4.0</u> <u>9.0</u>	<u>5.0</u> <u>9.0</u>
42.2 <u>44.2</u>	Restaurant (0212-2015)	16.0 spaces per 100 m ² GFA - non-residential <u>Up to 220 m² GFA - non-residential</u> <u>Over 220 m² GFA - non-residential</u>	<u>3.0</u> <u>6.0</u>	<u>3.0</u> <u>6.0</u>	<u>4.0</u> <u>9.0</u>	<u>5.0</u> <u>9.0</u>

Column	A	B	<u>C</u>	<u>D</u>	<u>E</u>	<u>F</u>
Line 1.0	TYPE OF USE	MINIMUM OFF-STREET PARKING REGULATION <u>UNIT OF MEASUREMENT</u>	<u>PRECINCT 1</u>	<u>PRECINCT 2</u>	<u>PRECINCT 3</u>	<u>PRECINCT 4</u>
42.3 <u>44.3</u>	Take-out Restaurant <i>(0212-2015)</i>	6.0 spaces per 100 m² GFA - non-residential	<u>3.0</u>	<u>3.0</u>	<u>4.0</u>	<u>5.0</u>
42.4	Restaurant (in a C4 zone) <i>(0308-2011); (0212-2015)</i>	9.0 spaces per 100 m² GFA - non-residential				
43.0 <u>45.0</u>	Schools:					
43.1 <u>45.1</u>	College, University	1.1 spaces per 100 m² GFA - non-residential used for academic purposes; plus 0.15 spaces per resident student and/or staff	1.1 plus 0.15	1.1 plus 0.15	1.1 plus 0.15	1.1 plus 0.15
43.2 <u>45.2</u>	Public/Private School (up to and including Grade 8)	1.0 space per 100 m² GFA - non-residential (excluding portables) plus 1.0 spaces per portable classroom ⁽³⁾	1.0 plus 1.0	1.0 plus 1.0	1.0 plus 1.0	1.0 plus 1.0
43.3 <u>45.3</u>	Public/Private School (Grade 9 and above)	1.5 spaces per 100 m² GFA - non-residential (excluding portables) plus 1.0 spaces per portable classroom ⁽³⁾	1.5 plus 1.0	1.5 plus 1.0	1.5 plus 1.0	1.5 plus 1.0
43A.0 <u>46.0</u>	Science and Technology Facility <i>(0325-2008)</i>	3.2 spaces per 100 m² GFA - non residential	<u>2.0</u>	<u>2.5</u>	<u>2.8</u>	<u>3.0</u>
43B.0 <u>47.0</u>	Self Storage Facility <i>(0308-2011)</i>	0.6 spaces per 100 m² GFA - non-residential (exclusive of storage parking)	<u>0.25</u>	<u>0.25</u>	<u>0.25</u>	<u>0.25</u>
33.0 <u>48.0</u>	Personal Service Establishment	spaces per 100 m² GFA - non-residential	<u>3.0</u>	<u>3.0</u>	<u>4.0</u>	<u>5.0</u>
33.1	Personal Service Establishment <i>deleted by (0XXX-2022)</i>	5.4 spaces per 100 m² GFA - non-residential				
33.2	Personal Service Establishment (in C4 zone)	4.0 spaces per 100 m² GFA - non-residential				
33.3	Personal Service Establishment (in CC2 to CC4 zones) <i>(0207-2008)</i>	4.3 spaces per 100 m² GFA - non-residential				

Column	A	B	<u>C</u>	<u>D</u>	<u>E</u>	<u>F</u>
Line 1.0	TYPE OF USE	MINIMUM OFF-STREET PARKING REGULATION <u>UNIT OF MEASUREMENT</u>	<u>PRECINCT 1</u>	<u>PRECINCT 2</u>	<u>PRECINCT 3</u>	<u>PRECINCT 4</u>
44.0 <u>49.0</u>	Transit Terminal	1.0 space per staff on duty with a minimum of 2.0 spaces	1.0	1.0	1.0	1.0
45.0 <u>50.0</u>	Truck Terminal	3.2 spaces per 100 m ² GFA - non-residential used for office purposes, and/or 1.1 spaces per 100 m ² GFA - non-residential used for warehouse/distribution facility	<u>2.0</u> and/or 1.1	<u>2.5</u> and/or 1.1	<u>2.8</u> and/or 1.1	<u>3.0</u> and/or 1.1
46.0 <u>51.0</u>	Utility:					
46.1 <u>51.1</u>	Utility Building	1.0 space per staff on duty with a minimum of 2.0 spaces	1.0	1.0	1.0	1.0
46.2 <u>51.2</u>	Water Treatment Facility	1.0 space per staff on duty with a minimum of 2.0 spaces	1.0	1.0	1.0	1.0
46.3 <u>51.3</u>	Sewage Treatment Plant	1.0 space per staff on duty with a minimum of 2.0 spaces	1.0	1.0	1.0	1.0
46.4 <u>51.4</u>	Electric Transformer and Distribution Facility	1.0 space per staff on duty with a minimum of 2.0 spaces	1.0	1.0	1.0	1.0
46A.0 <u>52.0</u>	Vehicle Pound Facility (0358-2007)	3.2 spaces per 100 m ² GFA - non-residential used for office, with a minimum of 4 spaces	<u>2.0</u>	<u>2.5</u>	<u>2.8</u>	<u>3.0</u>
47.0 <u>53.0</u>	Veterinary Clinic	3.6 spaces per 100 m ² GFA - non-residential	<u>3.0</u>	<u>3.0</u>	3.6	3.6
48.0 <u>54.0</u>	Warehouse/Distribution Facility, Wholesaling Facility (Single-Occupancy Building) ⁽⁶⁾ (0308-2011)	1.1 spaces per 100 m ² GFA - non-residential up to 6 975 m ² GFA - non-residential ; and 0.6 spaces per 100 m ² GFA - non-residential over 6 975 m ² GFA - non-residential	1.1 and 0.6	1.1 and 0.6	1.1 and 0.6	1.1 and 0.6
49.0 <u>55.0</u>	Warehouse/Distribution Facility, Wholesaling Facility (Multiple-Occupancy Building) ⁽⁵⁾	1.1 spaces per 100 m ² GFA - non-residential Parking for individual warehouse/distribution occupancies and wholesaling occupancies which exceed a GFA - non-residential of 6 975 m ² shall be calculated in accordance with the regulations applicable to warehouse/distribution facilities, wholesaling facilities (Single-Occupancy Building).	1.1	1.1	1.1	1.1

Column	A	B	<u>C</u>	<u>D</u>	<u>E</u>	<u>F</u>
Line 1.0	TYPE OF USE	MINIMUM OFF-STREET PARKING REGULATION <u>UNIT OF MEASUREMENT</u>	<u>PRECINCT 1</u>	<u>PRECINCT 2</u>	<u>PRECINCT 3</u>	<u>PRECINCT 4</u>
50.0 <u>56.0</u>	Waste Processing Station	1.6 spaces per 100 m ² GFA - non-residential up to 2 325 m ² GFA - non-residential; and 1.1 spaces per 100 m ² GFA - non-residential between 2 325 m ² and 9 300 m ² GFA - non-residential; and 0.6 spaces per 100 m ² GFA - non-residential over 9 300 m ² GFA - non-residential	1.6 and 1.1 and 0.6	1.6 and 1.1 and 0.6	1.6 and 1.1 and 0.6	1.6 and 1.1 and 0.6
51.0 <u>57.0</u>	Waste Transfer Station	1.1 spaces per 100 m ² GFA - non-residential up to 6 975 m ² GFA - non-residential; and 0.6 spaces per 100 m ² GFA - non-residential over 6 975 m ² GFA - non-residential	1.1 and 0.6	1.1 and 0.6	1.1 and 0.6	1.1 and 0.6
52.0 <u>58.0</u>	Other Non-Residential Uses Not Specified Above	5.4 spaces per 100 m ² GFA - non-residential	5.4	5.4	5.4	5.4

- NOTES: (1) See Sentence 3.1.2.2.1 of this By-law. (0018-2021)
(2) See also Subsection 3.1.5 of this By-law.
(3) See also Article 3.1.1.11 of this By-law.
(4) See Sentence 3.1.2.2.2 of this By-law. (0018-2021)
(5) See Sentence 3.1.2.2.3 of this By-law. (0018-2021)
(6) See Sentence 3.1.2.2.4 of this By-law. (0018-2021)

3.1.2.3 C4 Zone Parking Requirement

For the purpose of Article 3.1.2.2, off-street parking spaces for non-residential uses in C4 zones shall be provided in accordance with Precinct 1 requirements in Table 3.1.2.2.

3.1.2.34 Mixed Use Development Shared Parking

A shared parking formula may be used for the calculation of required parking for a mixed use development. A mixed use development means the following:

- (1) Non-office uses in an office or medical office building or group of buildings on the same lot;
- (2) Office or medical office space in a building or group of buildings on the same lot primarily occupied by retail uses;
- (3) A building or group of buildings on the same lot containing a mix of office or medical office, commercial uses and dwelling units;
- (4) Non-residential uses in an apartment (0174-2017)

Shared parking is to be calculated in compliance with Table 3.1.2.4 3 - Mixed Use Development Shared Parking Formula. (0018-2021)

The initial step in determining required parking for a mixed use development is to calculate the parking requirement for each use in the development as if these uses were free-standing buildings. The parking requirement for each use is then multiplied by the percent of the peak period for each time period (i.e. noon), contained in Table 3.1.2.43 - Mixed Use Development Shared Parking Formula. Each column is totalled for weekday and weekend. The highest figure obtained from all time periods shall become the required parking for the mixed use development.

3.1.3 Accessible Parking Spaces

~~3.1.3.3 C4 Zone Exception~~

~~Accessible parking spaces shall not be required in C4 zones where the required number of on-site parking spaces is 15 or less.~~

Part 4: Residential Zones

4.1 General Provisions for Residential Zones

4.1.20.9 ~~In addition to the required number of parking spaces for the dwelling, one parking space shall be required for a second unit;~~ Additional parking spaces shall not be required for a second unit.