



# Updated Environmental Impact Study

**2935 & 2955 Mississauga Road, City of Mississauga**

**590816 Ontario Inc.**

2616 Cynara Road  
Mississauga, ON, L5B 2R7

Prepared by:

**SLR Consulting (Canada) Ltd.**

300 Town Centre Blvd., Suite 200, Markham, ON L3R 5Z6

SLR Project No.: 209.065271.00001

Client Reference No: 1903701

April 28, 2026

Revision: G

## Revision Record

<b>Revision</b>	<b>Date</b>	<b>Prepared By</b>	<b>Checked By</b>	<b>Authorized By</b>
F	December 18, 2025	AA	DJ	DJ
G	April 28, 2026	AA	DJ	DJ



## Statement of Limitations

This report has been prepared by SLR Consulting (Canada) Ltd. (SLR) for 590816 Ontario Inc. (Client) in accordance with the scope of work and all other terms and conditions of the agreement between such parties. SLR acknowledges and agrees that the Client may provide this report to government agencies, interest holders, and/or Indigenous communities as part of project planning or regulatory approval processes. Copying or distribution of this report, in whole or in part, for any other purpose other than as aforementioned is not permitted without the prior written consent of SLR.

Any findings, conclusions, recommendations, or designs provided in this report are based on conditions and criteria that existed at the time work was completed and the assumptions and qualifications set forth herein.

This report may contain data or information provided by third party sources on which SLR is entitled to rely without verification and SLR does not warranty the accuracy of any such data or information.

Nothing in this report constitutes a legal opinion nor does SLR make any representation as to compliance with any laws, rules, regulations, or policies established by federal, provincial territorial, or local government bodies, other than as specifically set forth in this report. Revisions to legislative or regulatory standards referred to in this report may be expected over time and, as a result, modifications to the findings, conclusions, or recommendations may be necessary.



# Table of Contents

<b>Statement of Limitations</b> .....	<b>ii</b>
<b>Table of Contents</b> .....	<b>iii</b>
<b>Acronyms and Abbreviations</b> .....	<b>vi</b>
<b>1.0 Introduction</b> .....	<b>1</b>
<b>2.0 Environmental Policy</b> .....	<b>1</b>
2.1 Migratory Birds Convention Act (1994) .....	1
2.2 Species Conservation Act (2025) .....	1
2.3 Provincial Planning Statement (2024).....	4
2.4 Greenbelt Plan (2017) .....	4
2.5 Peel Region Official Plan (2022).....	5
2.6 City of Mississauga Official Plan (2011) .....	6
2.7 Credit Valley Conservation Policies and Regulations .....	7
<b>3.0 Study Approach</b> .....	<b>8</b>
3.1 Planning Context .....	8
3.2 Natural Heritage Information .....	8
3.3 Agency Consultation .....	9
3.4 Field Investigations.....	9
3.5 Species at Risk Habitat Screening .....	10
3.5.1 Bat Habitat Tree (Snag) Surveys.....	11
3.6 Significant Wildlife Habitat Screening .....	11
<b>4.0 Existing Conditions</b> .....	<b>11</b>
4.1 Site Description .....	11
4.2 Physiography, Geography, and Hydrology .....	12
4.3 Environmental Designations .....	13
4.4 Vegetation Communities .....	13
4.5 Flora .....	17
4.6 Breeding Birds.....	18
4.7 Breeding Amphibians .....	18
4.8 Incidental Wildlife Observations.....	18
4.9 Aquatic Assessment.....	18
<b>5.0 Assessment of Significance</b> .....	<b>19</b>
5.1 Significant Woodland.....	19
5.2 Significant Valleyland .....	19



5.3	Species at Risk Screening.....	20
5.3.1	SAR Birds.....	20
5.3.2	SAR Bats.....	20
5.3.3	SAR Fish.....	21
5.3.4	Snapping Turtle.....	21
5.4	Significant Wildlife Habitat.....	22
<b>6.0</b>	<b>Proposed Development.....</b>	<b>22</b>
<b>7.0</b>	<b>Impact Assessment and Mitigation Measures.....</b>	<b>25</b>
7.1	Vegetation Removal.....	25
7.2	Variable Buffer and Additional Restoration Areas.....	25
7.2.1	Net Gain in Buffer Area.....	26
7.2.2	Native Species Restoration.....	26
7.2.3	Buffer Function Effectiveness.....	26
7.3	Woodland Connectivity and the Reinstated Site Access.....	27
7.3.1	Wildlife Connectivity – Culvert Design.....	28
7.4	Artificial Pool Removal.....	29
7.5	Aquatic Species Mitigation.....	29
7.6	Bat Habitat Potential.....	30
7.7	Bird Friendly Design.....	31
7.8	Invasive Species Management Plan.....	31
7.8.1	Construction Equipment.....	32
7.8.2	Equipment Cleaning Stations.....	32
<b>8.0</b>	<b>Policy Conformity.....</b>	<b>32</b>
<b>9.0</b>	<b>Conclusions.....</b>	<b>34</b>
<b>10.0</b>	<b>Closure.....</b>	<b>34</b>
<b>11.0</b>	<b>References.....</b>	<b>35</b>

## Tables in Text

Table 1:	Field Investigations.....	9
Table 2:	Vegetation Community Descriptions.....	14
Table 3:	Locally Rare or Uncommon Native Species in the Subject Site.....	17
Table 4:	Potential Bat Habitat Trees $\geq 25$ cm DBH Adjacent to Proposed Development.....	21
Table 5:	Policy Conformity.....	32



## Figures in Text

Figure 1: Site Location.....	3
Figure 2: Existing Conditions .....	16
Figure 3: Constraints and Opportunities .....	24

## Maps in Text

Map A: Greenbelt (dark green outline) with Urban River Valley (blue shading) (MNRF, 2020). .....	5
Map B: Core Area in green present within and adjacent to the Subject Site (Peel Region OP, Schedule A).....	6
Map C: Significant Natural Areas and Natural Green Spaces (light green shading) (City of Mississauga OP, Schedule 3).....	7
Map D: CVC Regulation Limits in the vicinity of the Subject Site (cvc.ca).....	7
Map E: Significant Natural Area (CRR7) (City of Mississauga, 2017).....	13

## Appendices

<b>Appendix A</b>	<b>Agency Correspondence</b>
<b>Appendix B</b>	<b>Flora List and Air Photo Review</b>
<b>Appendix C</b>	<b>Breeding Bird Survey Results</b>
<b>Appendix D</b>	<b>Species at Risk Screening</b>
<b>Appendix E</b>	<b>Significant Wildlife Habitat Screening</b>
<b>Appendix F</b>	<b>Bat Rocket Box Plans</b>



## Acronyms and Abbreviations

COSSARO	Committee on the Status of Species at Risk in Ontario
CVC	Credit Valley Conservation Authority
EIS	Environmental Impact Study
ESA	Endangered Species Act
ha	Hectares
m	Metre(s)
MBCA	Migratory Birds Convention Act
MBR	Migratory Birds Regulation
NHF	Natural Heritage Features
NHS	Natural Heritage System
OLT	Ontario Land Tribunal
OP	Official Plan
PPS	Provincial Planning Statement
SAR	Species at Risk
SARA	Species at Risk Act
SARO	Species at Risk in Ontario
SCA	Species Conservation Act
SLR	SLR Consulting (Canada) Ltd.



## 1.0 Introduction

SLR Consulting (Canada) Ltd. (SLR) was retained to complete this updated Environmental Impact Study (EIS) for 2935 & 2955 Mississauga Road, City of Mississauga, Regional Municipality of Peel (**Figure 1**). SLR issued a previous version of this EIS under the firm of Palmer Environmental Consulting Group Ltd., which was acquired by SLR in 2024. This updated EIS is based on works completed by SLR and a previous EIS Report prepared by Dougan and Associates' (Dougan) in 2017 (Dougan and Associates, 2017). Additional project review comments provided by City of Mississauga (the City) and the Credit Valley Conservation Authority (CVC) through the development application process have also been addressed and incorporated into this update.

The Subject Site is composed of two properties (2935 and 2955 Mississauga Road) adjacent to each other that combined are 2.13 hectares (ha). The Subject Site comprises a largely open meadow central area and is surrounded by naturalized treed areas to the east, south and west. The northern limit of the Subject Site is directly adjacent to the Credit River. No structures, with the exception of an abandoned swimming pool, exist on the property. The proposed development consists of a multi-story apartment building and a group of mid-density stacked townhouses.

The objectives of this EIS are to evaluate the existing natural heritage features and ecological functions associated with the site, identifying development constraints and restoration opportunities, assessing the impacts of the proposed development, and recommending suitable mitigation measures.

## 2.0 Environmental Policy

### 2.1 Migratory Birds Convention Act (1994)

The Federal *Migratory Birds Convention Act*, MBCA (1994) and Migratory Birds Regulations, MBR (2014) protect most species of migratory birds and their nests and eggs anywhere they are found in Canada. General prohibitions under the MBCA and MBR protect migratory birds, their nests and eggs and prohibit the deposit of harmful substances in waters / areas frequented by them. The MBR includes an additional prohibition against incidental take, which is the inadvertent harming or destruction of birds, nests or eggs.

Compliance with the MBCA and MBR is best achieved through a due diligence approach, which identifies potential risk, based on a site-specific analysis in consideration of the Avoidance Guidelines and Best Management Practices information on the Environment Canada website (Government of Canada, 2023).

### 2.2 Species Conservation Act (2025)

On June 5, 2025, the Province of Ontario passed Bill 5: *Protect Ontario by Unleashing Our Economy Act, 2025*, which involved amendments to the Endangered Species Act (ESA) and enacted the *Species Conservation Act, 2025* (SCA) (Government of Ontario, 2026).

The SCA came into effect on March 30, 2026; it replaces the *Endangered Species Act* (2007), which was repealed on the same date. This *Act* is administered by the Ministry of Environment, Conservation and Parks (MECP), as was the previous ESA. The SCA protects Endangered and Threatened Species in Ontario that are listed in the *O. Reg. 60/26: Protected Species in Ontario List* (PSO). This list excludes formerly listed migratory birds and aquatic species (potentially



protected through the federal *Species at Risk Act*) as well as all previously listed Special Concern species that are not protected through the SCA. For most listed species, where impacts to the protected species are anticipated, a registry and Conservation Plan approach is taken whereby mitigation measures are expected to be taken.

Species listed as Special Concern may be afforded protection through policy instruments respecting significant wildlife habitat (e.g., the PPS) as defined by the Province, other relevant authority, or other protections contained in Official Plans.

Associated regulations include the following:

#### *Species Protection*

- Undertaking an activity that results in harassment of a species is no longer prohibited under the SCA and therefore does not require you to seek a permit or make use of an exemption.

#### *Habitat Protection*

- The new definition of 'habitat' does not include indirect habitat used exclusively for foraging or for travelling between dwelling places.
- Under the SCA, habitat is defined as:
  - For animals, the dwelling place and immediate surrounding area.
  - For plants, 'habitat' is defined as the critical root zone.
  - For all other species (for example, lichens), an area on which any member of the species directly depends to carry out its life processes.

The changes are intended to streamline permit applications and approvals and help projects proceed more quickly while continuing to provide important protections for SAR and their habitat. It remains the proponent's responsibility to ensure conformity with the SCA.

Under the SCA, provincial authorization for migratory birds and aquatic species (fish and mussels) listed on Schedule 1 of the federal Species at Risk Act (SARA) would not be required.



Last Saved: Wednesday, October 8, 2025 1:23 PM by sean.murray  
 GIS PATH: G:\Projects\209\209\_065271\_2935\_2955\_MississaugaRa1\1\_Workspace1\_Maps\20250703\_Ecology\Figures\203\_065271\_EIS\_Figures.aprx || 209\_065271-1-1\_Site Location

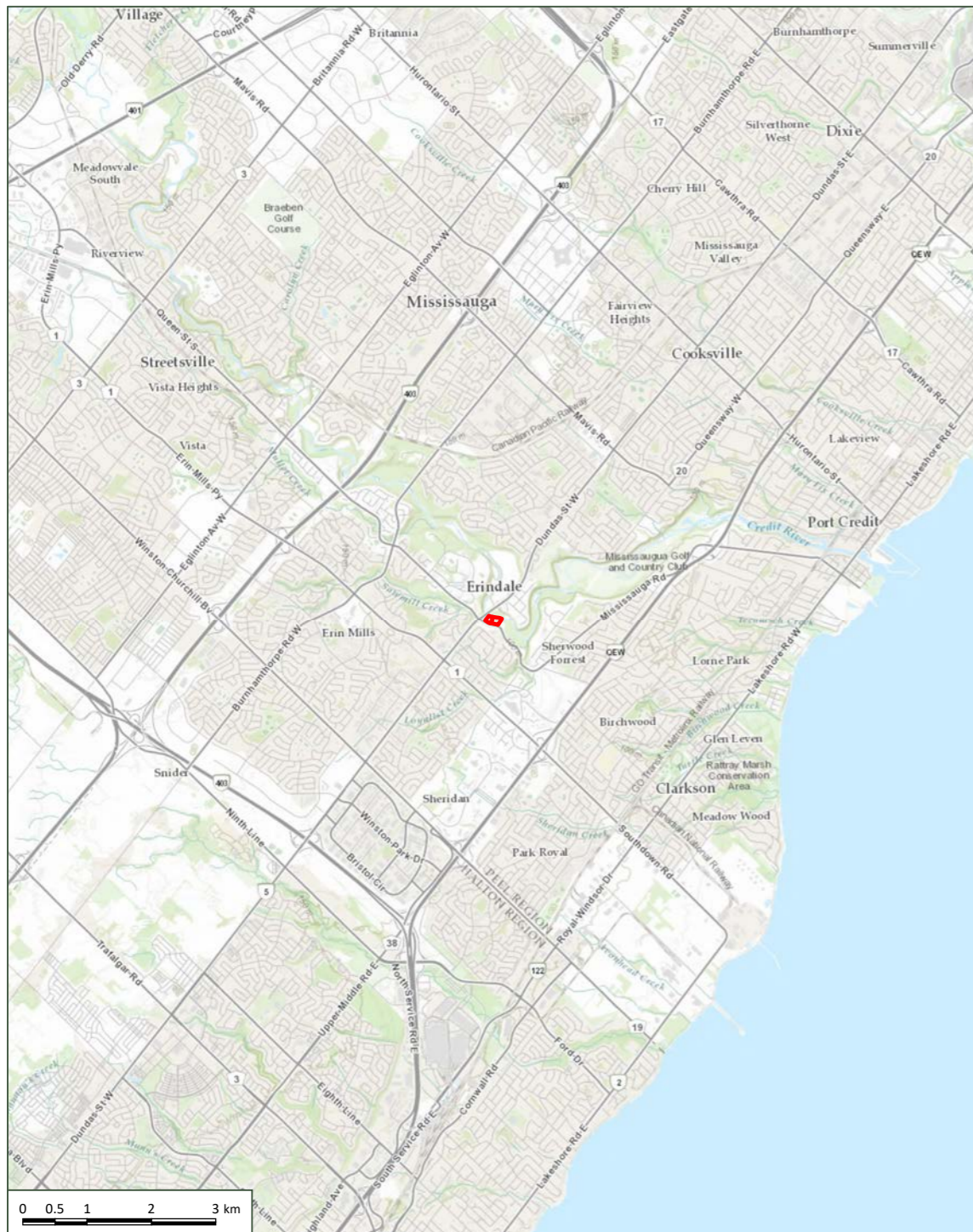

**LEGEND:**  
 SUBJECT SITE (2.13 HA)

**SERVICE LAYER CREDITS:** PEEL REGION 2020, CITY OF TORONTO, REGION OF PEEL, PROVINCE OF ONTARIO, ONTARIO MNR, ESRI CANADA, ESRI, HERE, GARMIN, INCREMENT P, USGS, MET/NASA, EPA, USDA, AAFC, NRCAN

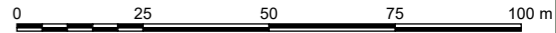

SCALE 1:1,500  
 PAGE SIZE 11 x 17  
 NAD 1983 CSRS UTM Zone 17N  
 THIS MAP IS FOR CONCEPTUAL PURPOSES ONLY  
 AND SHOULD NOT BE USED FOR NAVIGATION

590816 ONTARIO INC. C/O G. MERULLA INC.  
 2935 & 2955 MISSISSAUGA RD  
 MISSISSAUGA ON

2935 & 2955 MISSISSAUGA RD - 2025

**SITE LOCATION**

**SLR** FIGURE NO:  
**1**

DATE: November 26, 2025 PROJECT NO: 209.065271.00001

## 2.3 Provincial Planning Statement (2024)

The Provincial Planning Statement (PPS) provides direction to regional and local municipalities regarding planning policies for the protection and management of natural heritage features and resources (Ministry of Municipal Affairs and Housing, 2024). Section 4.1 of the PPS defines 10 natural heritage features (NHF) and adjacent lands and provides planning policies for each. Of these NHF, development is not permitted in:

- Significant Coastal Wetlands;
- Significant Wetlands in Ecoregions 5E, 6E and 7E;
- Fish Habitat, except in accordance with provincial and federal requirements; or
- Habitat of species designated as Endangered and Threatened, except in accordance with provincial and federal requirements.

Additionally, unless it can be demonstrated through an EIS that there will be no negative impacts on the natural features or their ecological functions, development and site alteration are also not permitted in:

- Significant Wetlands in the Canadian Shield north of Ecoregions 5E, 6E and 7E;
- Significant Woodlands in Ecoregions 6E and 7E (excluding islands in Lake Huron and the St. Mary's River);
- Significant Valleylands in Ecoregions 6E and 7E (excluding islands in Lake Huron and the St. Mary's River);
- Significant Wildlife Habitat;
- Significant Areas of Natural and Scientific Interest;
- Other Coastal Wetlands in Ecoregions 5E, 6E and 7E; and
- Lands defined as Adjacent Lands to all the above natural heritage features.

Each of these natural heritage features is afforded varying levels of protection subject to guidelines, and in some cases, regulations. The Subject Site is located in Ecoregion 7E (Crins, Gray, Uhlig, & Wester, 2009).

## 2.4 Greenbelt Plan (2017)

The Greenbelt Plan was prepared and approved under the *Greenbelt Act, 2005* and took effect in December 2004, and was updated in 2017 as part of a coordinated review. The Greenbelt Plan builds on the PPS to identify where urbanization should not occur in order to provide permanent protection to the agricultural land base and the ecological and hydrological features, areas and functions occurring on the landscape of the Greater Golden Horseshoe (Ontario Ministry of Municipal Affairs and Housing, 2017).

The Subject Site is within the Greenbelt's Urban River Valley System (**Map A**). The Urban River Valley designation applies to lands within the main corridors of river valleys connecting the rest of the Greenbelt to the Great Lakes and inland lakes (section 6.1). Greenbelt Plan Section 6.2.1 states that *only public owned lands are subject to the policies of the Urban River Valley designation*. Section 3.2.6 (1.b.) states that municipalities, conservation authorities, other agencies and stakeholders should promote and undertake appropriate planning and design to ensure that external connections and Urban River Valley areas are maintained and/or enhanced.



As the Subject Site is private lands, the Greenbelt Plan does not apply to this application.



**Map A: Greenbelt (dark green outline) with Urban River Valley (blue shading) (MNR, 2020).**

## 2.5 Peel Region Official Plan (2022)

The Peel Region Official Plan (OP) was adopted by the Regional Council on July 11, 1996. The in-effect OP underwent office consolidation in 2018. Natural heritage features in Peel Region are protected by its Greenlands System, which consists of Core Areas, Natural Areas and Corridors, and Potential Natural Areas and Corridors. Core Areas are designated on Schedule A (Core Areas of the Greenlands System of Peel) of the Official Plan and are intended to represent the most important natural features in Peel, providing the best uninterrupted natural systems and highest biodiversity as identified through the OP.

Natural Areas and Corridors and Potential Natural Areas and Corridors are to be identified and protected in lower tier municipal official plans in accordance with the policies outlined in the Peel Official Plan (Region of Peel, 2022).

The Subject Site is identified as part of the Region's Greenlands System (**Map B**). Per Section 2.3.2.6, development and site alteration are prohibited within Core Areas, however, "*the area municipalities are directed to adopt appropriate policies to allow the exceptions subject to it being demonstrated that there is no reasonable alternative location outside of the Core Area and the use, development or site alteration is direction away from the Core Area feature to the greatest extent possible; and the impact to Core Area features is minimized and any impact to the feature or its functions that cannot be avoided is mitigated through restoration or enhancement to the greatest extent possible*" (Region of Peel, 2022).

Note that on July 1, 2024, under the *Planning Act*, Peel Region was designated an "*upper-tier municipality without planning responsibilities*." As a result, the sections of the Regional Official Plan applicable to Mississauga are now part of the City of Mississauga Official Plan. Consequently, the City of Mississauga is the land use planning authority responsible for review of the regional official plan in the context of this development application.





**Map B: Core Area in green present within and adjacent to the Subject Site (Peel Region OP, Schedule A).**

## 2.6 City of Mississauga Official Plan (2011)

The office consolidation of the City of Mississauga Official Plan has recently been updated which includes Ontario Land Tribunal (OLT) decisions and City Council approved Official Plan Amendments. The City's Green System makes up about 23% of the land area of Mississauga and is comprised of the Natural Heritage System (NHS), Urban Forest, Natural Hazard Lands, and Parks and Open Spaces. The Official Plan, Section 6.3.8 states that: *Buffers will be determined on a site-specific basis as part of an Environmental Impact Study or other similar study to the satisfaction of the City and appropriate conservation authority.* Section 6.3.12 (f) provides criteria for the identification of Significant Woodland.

Section 6.3.47 and 6.3.48 provides study requirements for development adjacent to Valleylands. These policies state that *“Development and site alteration will not be permitted within erosion hazards associated with valleyland and watercourse features. In addition, development and site alteration must provide appropriate buffer to erosion hazards, as established to the satisfaction of the City and appropriate conservation authority”*. These limits are to be *“supported by detailed slope stability and stream erosion studies, where appropriate”*.

The proposed building envelope is surrounded by, but is not included in, the Greenlands System on OP Schedule 3 – Natural Systems (**Map C**). The Greenlands System includes Significant Natural Areas, Natural Green Spaces, and Natural Hazards. Section 6.3.26 states that lands determined as Significant Natural Areas and their buffers will be designated and zoned as Greenlands to ensure their long-term protection. Section 6.3.27 states that *development and site alteration as permitted in accordance with the Greenlands designation will not be permitted unless all reasonable alternatives have been considered and any negative impacts minimized. Any negative impact that cannot be avoided will be mitigated through restoration and enhancement to the greatest extent possible* (City of Mississauga, 2011). The City has adopted a new official plan but it is under review by the Province and is therefore not in-force.





**Map C: Significant Natural Areas and Natural Green Spaces (light green shading) (City of Mississauga OP, Schedule 3).**

## 2.7 Credit Valley Conservation Policies and Regulations

The CVC regulates hazard lands including watercourses, valleylands, shorelines, and wetlands, including lands adjacent to these features under the Conservation Authorities Act through Ontario Regulation 41/24 – Prohibited Activities, Exemptions and Permits.

The Subject Site is within the CVC Regulated Area (**Map D**). The associated CVC policies, regulations and permitting will therefore apply and approvals will be required from the agency. Note that as of April 1, 2024 with O. Reg. 41/24, conservation authorities no longer have the ability to comment on certain natural heritage features; however, the regulation of flooding and erosion hazards remains with the conservation authority.



**Map D: CVC Regulation Limits in the vicinity of the Subject Site (cvc.ca)**



## 3.0 Study Approach

### 3.1 Planning Context

A Planning Justification and Rationale Report was originally prepared by Beacon Planning Services (2020) in support of the proposed development applications. While that report provided an overview of the site history, natural features, and policy framework at the time, the planning context has since evolved substantially. A new Planning Opinion Letter prepared by Malone Given Parsons Ltd. (MGP, 2026) provides an updated and comprehensive review of the current planning policy framework, including the recently adopted Mississauga Official Plan and the Provincial Planning Statement, 2024. The Planning Opinion Letter builds upon and supersedes the previous Beacon report, providing a refined policy analysis, updated technical context, and an integrated rationale supporting the proposed development. This Environmental Impact Study should therefore be read in conjunction with the MGP Planning Opinion Letter, which represents the most current planning rationale and policy interpretation for the Subject Lands.

### 3.2 Natural Heritage Information

Palmer has reviewed relevant background material to provide a focus on field investigation and ensure compliance with applicable regulations and policy. Background information collection is guided by the *Natural Heritage Information Request Guide* (Ministry of Natural Resources and Forestry, 2018). Current direction from the Ministry of Natural Resources and Forestry (MNR) and the Ministry of Environment, Conservation and Parks (MECP) is to gather natural heritage information and species occurrence records from available sources; the Natural Heritage Information Centre (NHIC) Make-a-Map application and database being the main source of information and records from the Ministry itself (Ministry of Natural Resources and Forestry, 2025). Information gathered is recommended to be balanced and supplemented by a professional ecological review of potential habitats and characteristics of a project site.

Background review for the Subject Site included the collection and review of relevant mapping and reports, including regulations and policies, Official Plans, and zoning by-laws; and the NHIC Make-a-Map application for species occurrences and designated area mapping. In addition to these sources, the following data sources were reviewed for the project:

- Natural Area Inventory (NAS): The NAS provides factsheets for the Natural Areas in the City of Mississauga (City of Mississauga, 2021).
- Environmental Impact Study – Murella Properties, 2953 and 2955 Mississauga Road (Dougan and Associates, 2017). The data from this previous EIS has been reviewed and incorporated into this document.
- Land Information Ontario (LIO) database (Government of Ontario, 2025). Contains provincial mapping of significant wildlife habitats.
- Fisheries and Oceans Canada (DFO): The DFO maintains mapping of aquatic SAR habitats, including the critical habitat, occupied, and contributing habitat ranges of SAR and Special Concern species (Fisheries and Oceans Canada, 2025).
- Ontario Breeding Bird Atlas (Bird Studies Canada, 2021).
- Ontario Butterfly Atlas (Toronto Entomologists Association, 2019).
- Ontario Reptile and Amphibian Atlas (Ontario Nature, 2019).



Following the Information Request Guide (Ministry of Natural Resources and Forestry, 2018), MECP advice and direction should be solicited once SAR interactions or potential interactions are identified via field investigation and analysis.

### 3.3 Agency Consultation

A Terms of Reference was circulated to the CVC and the City of Mississauga on June 14, 2019. Comments were received from both agencies on November 26, 2019; with additional comments in March and April 2024. The agency comments have been reviewed and taken into account in the preparation of this updated EIS (**Appendix A**).

A preliminary site meeting was conducted on September 17, 2019 with Palmer (SLR), CVC, and City staff. A second site meeting was conducted on January 24, 2020 to verify the top-of-slope limit and woodland limit that was pre-staked by Beacon Planning Services. The top-of-slope limit was accepted and confirmed by CVC during the site meeting. At that time, the woodland limit was not approved by CVC; however, CVC and the City recommended minor revisions to the woodland dripline. The minor revisions to the woodland limit are reflected in this report to represent the woodland limit in a manner that is satisfactory to the review agencies (**Figure 2**).

### 3.4 Field Investigations

Field investigations were conducted to collect existing conditions data on flora, fauna, natural features and ecological functions. Fieldwork was conducted by Dougan from 2013 to 2017, by Palmer (now SLR) in 2019, and SLR in 2025 (**Table 1**). Survey methodology for Palmer/SLR’s fieldwork is described below.

**Table 1: Field Investigations**

Ecological Survey	Dougan’s Fieldwork (2013-2017)	Palmer/SLR’s Fieldwork (2019 and 2025)
Vegetation surveys	October 2013, June 2014, May 2017	June 27, 2019, June 27, 2025
Breeding bird surveys	May and June 2014	June 14, 2019, June 10 and 27, 2025
Nocturnal amphibian surveys	April and May 2014	June 27, 2019 *
Snapping Turtle and Eastern Milksnake search	May and June 2014	Incidental observations*
Bat habitat characteristics	No specific survey	June 27, 2025

\*Incidental observations were recorded when on site with an emphasis on the area with the abandoned pool.

Dougan completed Snapping Turtle (*Chelydra serpentina*) and Eastern Milksnake (*Lampropeltis Triangulum*) searches. Four Snapping Turtle surveys were conducted in 2014 during mornings under fair weather conditions. The entire site was searched for any activity. Four surveys for Eastern Milksnake were conducted in 2014 following the MNRF Guelph District Milksnake Survey Protocol (Ontario Ministry of Natural Resources and Forestry, 2013).

#### Vegetation Communities and Flora

Vegetation community boundaries were delineated on field maps through the interpretation of recent aerial photographs and refined in the field based in Ecological Land Classification (ELC)



System for Southern Ontario (Lee, et al., 1998). Information collected during ELC surveys includes dominant species cover, community structure, as well as level of disturbance, presence of indicator species, and other notable features.

Botanical surveys were completed by traversing the site and recording species observed in each vegetation community. Local plant rarity status for Mississauga is based on CVC/Peel species ranks (Credit Valley Conservation Authority, 2002). Provincial plant status was based on the NHIC species list (Ministry of Natural Resources and Forestry, 2025) and the PSO list (Government of Ontario, 2025).

An evaluation of bat habitat characteristics was completed during 2025 surveys for the trees proposed to be removed.

### **Breeding Bird Survey**

A breeding bird survey was conducted following the principles of the Ontario Breeding Bird Atlas Guide for Participants – Point Counts (Bird Studies Canada, 2021). Breeding bird surveys were conducted on the Subject Site on June 14, 2019 to document the bird communities on the Subject Site along with flyovers and adjacent areas. To respond to municipal comments, an additional survey was completed on June 10 and 27, 2025, to provide a two-visit survey within the same season. In addition to standard protocols, the on-site bluffs were surveyed for Bank Swallow potential. SLR surveys were carried out between 07:00 and 09:00 h. Weather conditions during both surveys were 80% overcast, with moderate breezes, no precipitation, and 12°C and 18°C; the June 10, 2025 date had only light cloud cover. The surveyor recorded all bird species seen and heard within and flying over the survey area. The number, breeding evidence, and approximate location of each bird or bird group was recorded on the site map.

### **Breeding Amphibians**

An amphibian breeding survey was completed following the Environment Canada's Marsh Monitoring Program protocol (Bird Studies Canada, 2009) and was conducted on June 27, 2019. Species, calling locations and approximate numbers of calling individuals are recorded and mapped when present. A list of Area Sensitive species was referenced to determine habitat and species sensitivities (Ontario Ministry of Natural Resources, 2000). The survey method provides an indication of amphibian abundance during the breeding season. The air temperature at the time of the survey was 25°C, with light winds and clear skies. The survey location was focused on the swimming pool for breeding amphibians and snapping turtles.

### **Incidental Wildlife Observations**

Incidental observations of wildlife were recorded during all visits to the Subject Site. Recorded wildlife observations included direct and indirect evidence. Direct evidence included visual or auditory observations of species. Evidence considered "indirect" included observation of tracks, scat, and browse.

## **3.5 Species at Risk Habitat Screening**

For the purposes of this report, SAR include species listed as *Endangered*, *Threatened* or *Special Concern* under Ontario's SCA. The protection provisions for species and their habitat within the SCA apply only to those species listed as Endangered or Threatened on the PSO list. Special Concern species may be afforded protection through policy instruments respecting significant wildlife habitat as defined by the Province or other relevant authority, or other protections contained in Official Plan policies.



Prior to field work, existing SAR records were queried with the NHIC database and other background resources (Ministry of Natural Resources and Forestry, 2025). Habitat opportunities for SAR on the site were then assessed by comparing habitat preferences of species deemed to have potential to occur against current site conditions. The species noted during the NHIC search and others known through professional experience to have potential to occur were considered in the assessment.

### 3.5.1 Bat Habitat Tree (Snag) Surveys

As SAR bats were screened as having potential habitat within or adjacent to the Subject Site, a survey for potential habitat tree (snag) identification was completed. Based on MNRF guideline, *Maternity Roost Surveys (Forests/Woodlands)*, Little Brown Myotis (*Myotis lucifugus*), Northern Myotis (*Myotis septentrionalis*) and Tri-colored Bat (*Perimyotis subflavus*) may establish maternity roosts in any coniferous, deciduous or mixed wooded ecosite that includes trees at least 25 cm diameter-at-breast height (DBH) and should be considered suitable maternity roost habitat (Ministry of Natural Resources and Forestry, 2022). In 2025, three migratory bat species were also listed as *Endangered* under the SCA: Eastern Red Bat (*Lasiurus borealis*), Hoary Bat (*Lasiurus cinereus*) and Silver-haired Bat (*Lasionycteris noctivagans*). Based on communications with MECP there is no formal survey guidance on these three bat species. Therefore, survey methods proceeded with the MNRF (2022) protocol.

Based on aerial imagery and ELC field investigations, treed areas adjacent to the proposed development limit (plus 6 m) were identified within the Subject Site. A search for potentially suitable bat maternity roosting trees was conducted on June 27, 2025. Snags  $\geq 25$  cm diameter at DBH identified as potential roost trees were recorded. The tree species, DBH, snag attributes (i.e., cavities, loose bark, cracks), snag location, height class, and decay class were recorded for each tree.

## 3.6 Significant Wildlife Habitat Screening

SLR has developed a screening tool for Significant Wildlife Habitat (SWH) for Ecoregion 7E, following the relevant criteria established by the Province (Ministry of Natural Resources and Forestry, 2025). As this project is within Peel Region, the *Peel-Caledon Significant Woodlands and Significant Wildlife Habitat Study* was also reviewed (North-South Environmental Inc., Dougan & Associates and Sorensen Gravely Lowes, 2009). Upon completion of surveys, the screening is reviewed based on observed site characteristics. This is supplemented by additional analysis, field observations, and mapping to determine if candidate SWH types exist and/or can be confirmed within or adjacent to the Subject Site.

## 4.0 Existing Conditions

### 4.1 Site Description

The Subject Site is composed of two adjacent properties that combined are 2.13 ha (**Figure 2**). The Subject Site consists of a large open central area which is surrounded by treed vegetation communities to the east, south and west (**Photo 1**). The property at 2935 Mississauga Road historically supported a residential dwelling. No structures are currently present on the Subject Site except for remnants of the concrete bridge abutments for the small bridge that spanned over Sawmill Creek as part of the driveway that provided access to a dwelling from Mississauga Road. Several elements of the former dwelling also remain, including a concrete swimming



pool, sections of foundation footings, the cement floor and the partial back wall of the garage (Dougan and Associates, 2017).



**Photo 1: Central Open Area of the Subject Site, with treed areas on the sides (June 27, 2025 ).**

In response to agency comments, an aerial photo review was completed (**Appendix B**). This review provides general site context, though a more thorough review of earlier years (pre-1970) was completed by Dougan and Associates (2017). The review in **Appendix B** shows that the lands were open and cleared as far back as 1954. The 1966 image shows that a driveway to a home at 2935 Mississauga Road was established at the time, at the location of the driveway to be reestablished over the Sawmill Creek. Sawmill Creek was already a channelized feature even at that time, exiting a culvert at the Dundas Street and Mississauga Road intersection. The October 2004 image demonstrates that the section of Sawmill Creek within the Subject Site no longer functions as the Sawmill Creek Spillway now diverts waters prior to the properties. The October 2004 image also shows that the interior of the property at 2955 Mississauga Road had developed a vegetative cover; however, by December 2004, the interior of the property was largely devoid of that cover, and has largely been reflective of that state since that time, with current extents present between 2007 and 2009. The interior of 2955 Mississauga Road has been largely open and cleared lands in all reviewed images.

The northern limit of the Subject Site is directly adjacent to the Credit River. A channelized segment of the former Sawmill Creek at the confluence with the Credit River runs parallel to Dundas Street West, directly west of the Subject Site. This segment of Sawmill Creek underwent major changes in the 1970s when the creek was relocated and constructed into a concrete spillway. An ephemeral naturalized drainage channel is present along the part of the southern site boundary and bends along the eastern site boundary towards the Credit River. This feature is remnant of the diversion channel for Sawmill Creek created in the 1970s. The ephemeral naturalized drainage channel supports water flowing from the ravine lands located on the south side of Mississauga Road through culverts and seepage.

## 4.2 Physiography, Geography, and Hydrology

The Subject Site is located within the Iroquois Plain physiographic region. The slightly sloping plain is mostly covered with stratified sands of varying depths (Chapman & Putnam, 1984). The



Subject Site comprises undulating tableland and a steep ravine with bluffs associated with the Credit River watercourse valley system on the north side of the properties (Dougan, 2017). A portion of the Subject Site drains towards Mississauga Road where runoff is captured in an ephemeral naturalized drainage swale (not a natural watercourse as it is a remnant of the historical diversion channel created for Sawmill Creek) which runs along the bottom part of the southern portion of the site and then along the eastern edge of the Subject Site before flowing into the Credit River (**Figure 2**). This naturalized swale captures runoff from a very limited catchment area; the Subject Site and three culverts coming from the ravine on the opposite side of Mississauga Road, and as a result has minimal flow (Parish Aquatic Services, 2016).

### 4.3 Environmental Designations

The Subject Site does not include provincially designated features such as significant woodland, wetlands, Area of Natural and Scientific Interest (ANSIs) or Environmentally Significant/Sensitive Areas (ESAs). The natural area located adjacent to the site is identified as a Significant Natural Area (CRR7) as part of the NAS (City of Mississauga, 2021), which maps Fresh-Moist Willow Lowland Deciduous Forest (FOD7-3) adjacent to the Subject Site (**Map E**), and partly within the Greenbelt's Urban River Valley.



**Map E: Significant Natural Area (CRR7) (City of Mississauga, 2017)**

### 4.4 Vegetation Communities

The previous EIS identified six (6) ELC vegetation communities on the Subject Site, including Anthropogenic (ANTH), Dry-Moist Old Field Meadow (CUM1-1), Mineral Cultural Woodland (CUW1), Fresh-moist Sugar Maple – Lowland Ash Deciduous Forest (FOD6-1), Fresh-moist Willow Lowland Deciduous Forest (FOD7-3), and Open Clay Bluff (BLO1-1) (**Table 2; Figure 2**). During the 2019 and 2025 field surveys, the ELC communities were found to have remained large unchanged but have been updated based on current site conditions.



**Table 2: Vegetation Community Descriptions**

Vegetation Community	Descriptions
Mineral Cultural Woodland (CUW1)	<p>The western community adjacent to the channelized Saw Mill Creek has a canopy consisting of White Ash (<i>Fraxinus americana</i>), Norway Maple (<i>Acer platanoides</i>), American Elm (<i>Ulmus americana</i>), and Sweet Cherry (<i>Prunus avium</i>), providing approximately 50% cover. The understory layer is mostly comprised of invasive shrubs such as Tartarian Honeysuckle (<i>Lonicera tatarica</i>) and European Buckthorn (<i>Rhamnus cathartica</i>) along with Staghorn Sumac (<i>Rhus typhina</i>) and Black Raspberry (<i>Rubus occidentalis</i>). The ground layer is dominated by Garlic Mustard (<i>Alliaria petiolaris</i>). Evidence of past soil and debris dumping was noted (Dougan, 2017).</p> <p>The small northern community adjacent to the bluffs and the abandoned swimming pool has a higher diversity of native plants. The canopy comprises Black Oak (<i>Quercus velutina</i>) and Red Oak (<i>Quercus rubra</i>) along with Bur Oak (<i>Quercus macrocarpa</i>), White Oak (<i>Quercus alba</i>), Sugar Maple (<i>Acer saccharum</i>), Black Cherry (<i>Prunus serotina</i>), Sweet Cherry (<i>Prunus avium</i>), Green Ash, Eastern Hophornbeam (<i>Ostrya virginiana</i>), Trembling Aspen (<i>Populus tremuloides</i>), American Basswood (<i>Tilia americana</i>), Scots Pine (<i>Pinus sylvestris</i>), and Norway Spruce (<i>Picea abies</i>). The understory layer consists of Roundleaf Dogwood (<i>Cornus rugosa</i>), Juneberries (<i>Amelanchier arborea</i> and <i>A. spicata</i>), Chokecherry (<i>Prunus virginiana</i>), Red-osier Dogwood (<i>Cornus sericea</i>) alongside the invasive Tartarian Honeysuckle. The ground layer includes Canada Goldenrod (<i>Solidago canadensis</i>), Yarrow (<i>Achillea millefolium</i>), Spreading Dogbane (<i>Apocynum androsaemifolium</i>), Rough Cinquefoil (<i>Potentilla recta</i>), Canada Bluegrass (<i>Poa compressa</i>), King Devil (<i>Hieracium praealtum</i>), Field Goldenrod (<i>Solidago nemoralis</i>), Heart-leaf Aster (<i>Symphotrichum cordifolium</i>), Ditch-stonecrop (<i>Penthorum sedoides</i>) and Pussytoes (<i>Antennaria</i> sp.) (Dougan, 2017).</p>
Anthropogenic (ANTH)	<p>The Subject Site is mostly occupied by this anthropogenic area which has been cleared, graded, and tilled in the past. Herbaceous vegetation present mostly comprises White Sweet Clover (<i>Melilotus albus</i>), Canada Goldenrod (<i>Solidago canadensis</i>), Birds-foot Trefoil (<i>Lotus corniculatus</i>), Yarrow, Chickory (<i>Cichorium intybus</i>), Canada Thistle (<i>Cirsium arvense</i>), Wild Carrot (<i>Daucus carota</i>), and Fuller's Teasel (<i>Dipsacus fullunum</i>). Many patches of bare soil are present throughout (Dougan, 2017).</p>
Fresh-Moist Sugar Maple – Lowland Ash Deciduous Forest (FOD6-1)	<p>This community located in the northeastern portion of the Subject Site has a canopy comprised of Sugar Maple and Green Ash (<i>Fraxinus pennsylvanica</i>) with Paper Birch (<i>Betula papyrifera</i>), Black Cherry, American Elm, Eastern Hophornbeam, Eastern Cottonwood (<i>Populus deltoides</i>), Black Maple (<i>Acer nigrum</i>), and Manitoba Maple (<i>Acer negundo</i>) along the bank of the valleyland. The understory comprises various native and introduced shrubs including Chokecherry, Gray Dogwood (<i>Cornus racemosa</i>), Rose (<i>Rosa</i> sp.), Tartarian Honeysuckle, Raspberries (<i>Rubus</i> sp.) and Japanese Barberry (<i>Berberis thunbergii</i>). The very sparse ground layer includes such species as Yellow Avens (<i>Geum aleppicum</i>), Rough Avens (<i>Geum laciniatum</i>), Tall Butter-cup (<i>Ranunculus acris</i>), Garlic Mustard, Broad-leaved Goldenrod (<i>Solidago flexicaulis</i>), and Poison Ivy (<i>Toxicodendron radicans</i>) (Dougan, 2017).</p>
Fresh-Moist Willow Lowland Deciduous Forest (FOD7-3)	<p>This linear deciduous forest fragment runs parallel to Mississauga Road. The narrowness of the woodland results in the dominance of edge habitat. The canopy consists of Willows (<i>Salix</i> spp.) with Green Ash, American Basswood, American Elm, native and non-native Maples (<i>Acer</i> spp.) and Eastern White Pine (<i>Pinus strobus</i>). The understory layer includes Common Buckthorn, Roundleaf Dogwood, Common Red Raspberry (<i>Rubus idaeus</i>), Purple Flowering Raspberry (<i>Rubus odoratus</i>), Riverbank Grape (<i>Vitis riparia</i>) and Japanese Barberry. A relatively rich spring flora was observed</p>







Vegetation Community	Descriptions
	including Jack-in-the-Pulpit ( <i>Arisaema triphyllum</i> ), Yellow Trout-lily ( <i>Erythronium americanum</i> ), Wood Anemone ( <i>Anemone quinquefolia</i> ), Narrow-leaved Spring Beauty ( <i>Claytonia virginica</i> ) Wild Geranium ( <i>Geranium maculatum</i> ), Yellow Avens, Large-leaved Avens ( <i>Geum macrophyllum</i> ), John's Cabbage ( <i>Hydrophyllum virginianum</i> ), Cut-leaved Toothwort ( <i>Dentaria laciniata</i> ), False Solomon's Seal ( <i>Maianthemum racemosum</i> ), May Apple ( <i>Podophyllum peltatum</i> ), Bloodroot ( <i>Sanguinaria canadensis</i> ), Broad-leaved Goldenrod, Tall Meadow Rue ( <i>Thalictrum polygamum</i> ), and Violets ( <i>Viola sororia</i> , and others). Invasive plants including Garlic Mustard, Goutweed ( <i>Aegopodium podagraria</i> ), Creeping Euonymus ( <i>Euonymus fortunei</i> ), Scilla ( <i>Silla siberica</i> ) and Lily-of-the-Valley ( <i>Convallaria majalis</i> ) were also observed (Dougan, 2017).
Dry-Moist Old Field Meadow (CUM1)	The small patch of cultural meadow located beside the laneway entrance along Mississauga Road has a mix of early-successional, disturbance-tolerant forbs and grasses. These include Canada Goldenrod, White Sweet Clover, Birds-foot Trefoil, Orchard Grass ( <i>Dactylis glomerata</i> ), Kentucky Bluegrass ( <i>Poa pratensis</i> ), Creeping Wild-rye ( <i>Elymus repens</i> ) and Wild Carrot. A few woody species have begun to emerge including Tartarian Honeysuckle, Norway Maple, Sugar Maple and Trembling Aspen (Dougan, 2017).
Open Clay Bluff (BLO1-1)	This polygon is a steep clay and shale face which is largely open and eroding, with sparse cover of trees and shrubs, including Eastern White Cedar ( <i>Thuja occidentalis</i> ), Balsam Poplar ( <i>Populus balsamifera</i> ), Hop Hornbeam, and White Birch trees, and several severely leaning/hanging Eastern Hemlock ( <i>Tsuga canadensis</i> ) trees affected by steep grades and erosion. Understorey shrubs include Juneberries and Round-leaved Dogwood. The ground layer is sparsely covered by White Sweet Clover and Goldenrod ( <i>Solidago</i> sp.). Towards the west end, there is growth of Scots Pine, Gray Dogwood, European Buckthorn, and Goldenrod ( <i>Solidago</i> sp.) (Dougan, 2017).



GIS PATH: G:\Projects\209\209\_065271\_2935\_2955\_MississaugaRd11\_Workspace11\_Maps\20250703\_Ecology\Figures\203\_065271\_EIS\_Figures\aprx\_065271\_2-1\_Existing Environmental Conditions Last Saved: Wednesday, October 8, 2025 1:23 PM by sean.murray



- LEGEND:**
-  EPHEMERAL NATURALIZED DRAINAGE SWALE
  -  WOODLAND LIMIT (DELINEATED ON-SITE BY PALMER, FEB 2020)
  -  STAKED TOP OF BANK - APPROVED BY CVC (FEB 2020)
  -  ECOLOGICAL LAND CLASSIFICATION (ELC)
  -  SUBJECT SITE (2.13 HA)

- ELC Communities:**
- ANTH: Anthropogenic
  - BLO1-1: Open Clay Bluff
  - CUM1: Dry-Moist Old Field Meadow
  - CUW1: Mineral Cultural Woodland
  - FOD6-1: Fresh-Moist Sugar Maple - Lowland Ash Deciduous Forest
  - FOD7-3: Fresh-Moist Willow Lowland Deciduous Forest

SERVICE LAYER CREDITS: PEEL REGION2020

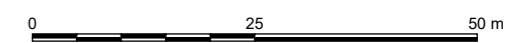

SCALE: 1:850  
PAGE SIZE: 11 x 17  
NAD 1983 CSRS UTM Zone 17N  
THIS MAP IS FOR CONCEPTUAL PURPOSES ONLY AND SHOULD NOT BE USED FOR NAVIGATION

590816 ONTARIO INC. C/O G. MERULLA INC.  
2935 & 2955 MISSISSAUGA RD  
MISSISSAUGA ON

2935 & 2955 MISSISSAUGA RD - 2025

**EXISTING ENVIRONMENTAL CONDITIONS**



FIGURE NO:  
**2**

## 4.5 Flora

A total of 176 flora species were recorded within and directly adjacent to the Subject Site (**Appendix B**). Of the species identified, 15 species were recorded to the genus only. Most of the plants recorded are native to the Peel Region and CVC's watershed. As many as 13 native species of regional / local significance were recorded of which all were found within the deciduous forest/woodland, and open bluff habitats on the Subject Site, except for Canada Honewort (*Cryptotaenia canadensis*) located in the Mineral Cultural Woodland (CUW1) in the north corner of the Subject Site (Dougan and Associates, 2017; City of Mississauga, 2021; Kaiser, 2001; Credit Valley Conservation Authority, 2002) (**Table 3, Figure 2**). No flora species provincial significance was recorded on the properties.

**Table 3: Locally Rare or Uncommon Native Species in the Subject Site**

Common Name	Scientific Name	ELC Types	Peel	Mississauga	CVC
Downey Serviceberry	<i>Amelanchier arborea</i>	CUW1 (River), BLO1-1		2	
Running Serviceberry	<i>Amelanchier spicata</i>	CUW1 (River), BLO1-1	R3		LR
Spreading Dogbane	<i>Apocynum androsemifolium</i>	CUW1 (River)		2	
Golden Sedge	<i>Carex aurea</i>	CUW1 (River), FOD6-1	U	2	
Canada Honewort	<i>Cryptotaenia canadensis</i>	CUW1(north), FOD7-3		2	
Canada Wild-rye	<i>Elymus canadensis</i>	FOD6-1			LR
Eastern Riverbank Wild-rye	<i>Elymus riparius</i>	FOD6-1	R3	1	LR
Spotted Geranium	<i>Geranium maculatum</i>	FOD7-3	U		
Star-flowered False Solomon's Seal	<i>Maianthemum stellatum</i>	FOD6-1, FOD7-3		2	
White Spruce	<i>Picea glauca</i>	CUW1 (River)	R3		LR
Black Oak	<i>Quercus velutina</i>	CUW1 (River)	R3	2	LR
Swamp Red Currant	<i>Ribes triste</i>	FOD7-3	U	3	
Marsh Blue Violet	<i>Viola cucullata</i>	FOD7-3	R6		LR

Peel (Kaiser, 2001): Rx = number of locations observed in Region. U = Uncommon in Region.

Mississauga (Mississauga, 2021): 1 = 1 to 3 locations in City, considered regionally significant. 2 = 4 to 10 locations in the City.

CVC: (CVC, 2002) – LR = Locally Rare



## 4.6 Breeding Birds

Between the 2017 (Dougan, 2017), 2019 and 2025 surveys, 34 bird species were observed, of which 15 were likely breeding on-site or in the local area, 14 possibly breeding in the area, and observed migrant species (**Appendix C**).

One area-sensitive species, White-breasted Nuthatch (*Sitta carolinensis*) was found within the Subject Site. Area-sensitive species require large areas of continuous habitat for breeding and foraging.

As many as six Bank Swallows were observed foraging and flying over the Credit River during the 2014 and 2019 breeding bird surveys. Bank Swallow (*Riparia riparia*) is designated as Threatened on the Federal SARA list. Based on these observations, it was felt that Bank Swallow could be nesting on the buffs at the northern limit of the Subject Site. However, in targeted 2025 surveys, no Bank Swallow or nesting evidence (burrows) was observed on-site. Northern-rough winged swallows (*Stelgidopteryx serripennis*), another bluff nesting species, was observed foraging in the area but there was no evidence of nesting on the bluff so they may be using the nearby Dundas Street West bridge or an adjacent slope.

## 4.7 Breeding Amphibians

No amphibians were detected during the 2014 or 2019 formal breeding amphibian surveys. However, a few frogs have been incidentally observed during other field surveys. All observations were within the abandoned swimming pool, including a Green Frog (*Lithobates clamitans*; adult and tadpole) and adult American Toads (*Anaxyrus americanus*; adult) observed in 2014 as well as two unidentified frogs observed in 2019. Given the small size of the swimming pool, as well as the urban context, it is likely only very small numbers of the more tolerant amphibians would be supported; thus, no significant level of breeding is expected.

## 4.8 Incidental Wildlife Observations

A raptor nest was observed in the Fresh-moist Willow Lowland Deciduous Forest (FOD7-3) in the southeast corner of the Subject Site.

No Snapping Turtle was observed during species surveys, but an individual was incidentally observed in 2014 in the abandoned swimming pool. This is a species of Special Concern. No Eastern Milksnake was observed during 2014 surveys and 2019 field visits.

The previous EIS included the finding of four mammal species during their 2014 field investigation; including Gray Squirrel (*Sciurus carolinensis*), Coyote (*Canis latrans*), Raccoon (*Procyon lotor*) and White-tailed Deer (*Odocoileus virginianus*). An Eastern Gartersnake (*Thamnophis sirtalis sirtalis*) was also observed. All of these species are considered common and widespread in southern Ontario and the local region.

## 4.9 Aquatic Assessment

The Credit River directly adjacent to the northern limit of the Subject Site is approximately 23 to 28 metres (m) wide with low to moderately sloped shallow riffles and runs, and shallow pools (Dougan, 2017). In-stream habitat is fairly diverse with gravelly portions and variable velocities. The upstream cobble and gravel bar potentially provide spawning habitat for suckers and migratory salmonids (Dougan, 2017). A moderate variety of substrates with interstitial spaces and variable depths and velocities may provide habitat for migratory American Eel (*Anguilla rostrata*) (Dougan, 2017).



There is an ephemeral naturalized drainage swale, also referred to as the former Sawmill Creek channel along the eastern property limit. The presence of downstream-oriented small woody debris and a conspicuous absence of vegetation and organic litter along the centre of the channel suggest the channel periodically conveys minor flow. Periodic flow could be a result of stormwater from the small upstream catchment or the falling limb of floods from the Credit River that inundate the lower section of the old channel. Along the periphery of the over-widened channel, deciduous trees are present suggesting flows rarely inundate the entire channel bed. A naturally formed levee and rafted woody debris block the mouth of the old Sawmill Creek channel at the confluence with Credit River. This feature is not hydrologically connected to an upstream watercourse. Fish passage from the Credit River is not possible due to the steep drop in grades. Therefore, this feature is not believed to provide fish habitat.

## 5.0 Assessment of Significance

### 5.1 Significant Woodland

The Fresh-Moist Sugar Maple – Lowland Ash Deciduous Forest (FOD6-1) and Fresh-Moist Willow Lowland Deciduous Forest (FOD7-3) are identified as a Core Area of the Region's Greenlands System. These forest communities are also identified as part of the City's Significant Natural Areas and Natural Green Spaces.

Based on the City's Significant Woodland criteria provided in section 6.3.12.f of the OP, the woodland is considered significant. On a landscape level assessment, the woodland extends south and east of the Subject Site. The woodland is greater than 0.5 ha and is located within 30 m of a watercourse. The City's OP states that woodland buffers are to be determined on a site-specific basis.

Based on the urban nature of the area, the historical use of the site, and the features and functions of the woodland, it is believed that a 10 m in width along the southern and eastern portions of the Subject Site would provide a suitable buffer between the existing woodland edge and the future medium density development. A 10 m buffer is consistent with CVC's regulatory requirements.

### 5.2 Significant Valleyland

The Subject Site includes a valleyland feature associated with the Credit River where the valley slope is characterized as an Open Clay Bluff (BLO1-1) vegetation community along the northern boundary of the site. The area is identified as Natural Hazards in the City's OP. It is noted that the project area is located on a tableland within the larger Credit River valley system, and the erosion and flooding hazard limits of the current, long-term river slopes has been determined and planned for. It should be noted that Mississauga Road itself, and other private properties are also located within this same tableland.

Mississauga Official Plan Sections 6.3.47 and 6.3.48 provides study requirements for development adjacent to Valleylands. These policies state that *“Development and site alteration will not be permitted within erosion hazards associated with valleyland and watercourse features. In addition, development and site alteration must provide appropriate buffer to erosion hazards, as established to the satisfaction of the City and appropriate conservation authority”*. These limits are to be *“supported by detailed slope stability and stream erosion studies, where appropriate”*.

The top of bank was staked in 2019 and approved by CVC staff in 2020. A geotechnical slope stability assessment was completed by Terraprobe in 2008 and an addendum report was issued



in 2010 (Terraprobe, 2008; Terraprobe, 2010). Terraprobe's study determined the Erosion Hazard Limit as defined by the Long-Term Stable Slope, which is a combination of Toe Erosion Allowance and Stable Slope Allowance (**Figure 4**). Based on the City's policies (section 6.3.48), any development adjacent to valleyland and watercourse features may be required to be supported by a detailed slope stability and stream erosion studies. SLR/Palmer has prepared a Stream Stability/Erosion Assessment review provided under a separate cover (Palmer, 2020).

The Proposed Development has been sited outside of the Erosion and Flood Hazards of the Credit River, which is supported by the Geotechnical, Hydrogeological and Stormwater Management Plan reports for the proposed development, provided as separate covers. These studies propose appropriate setbacks to these limits as outlined in the MNR Guidance Documents for determining the hazard limits. Following these guidelines, a 6 m setback for erosion access allowance from the Erosion Hazard Limit/Long-Term Stable Slope, as instructed in CVC's Regulation, is considered suitable (Greck, 2025).

### 5.3 Species at Risk Screening

The SCA provides protection for species listed as Endangered or Threatened in Ontario, including their habitat. The COSSARO list also identifies species of Special Concern that may become Threatened or Endangered in the future. Species of Special Concern and their habitats are not protected under the SCA.

Based on available background information and field investigations, the Subject Site and adjacent lands were screened for potential SAR habitat opportunities. The assessment was conducted by comparing habitat preferences of species deemed to have potential to occur against current site conditions, as well as knowledge from field investigations. This SAR habitat assessment can be found in **Appendix D** providing a detailed description of each species' habitat (including those deemed to not have potential habitat), as well as a discussion of habitat suitability within the Subject Site, potential impacts, and mitigation, where applicable.

Based on the rationale provided in **Appendix D**, the following 'short-list' of SAR species or SAR habitat merit further discussion as the species were observed, or have the potential to occur, within the Subject Site and adjacent lands:

#### 5.3.1 SAR Birds

Most avian species identified through the screening were determined not to have habitat on the Subject Site, as they were not observed in the 2014, 2019 or 2025 surveys. While Bank Swallow (*Riparia riparia*) was observed in 2014 and 2019, a specific survey to document bank swallow nesting structures was completed in 2025. No nesting cavities were observed in the on-site bluffs. It is felt that the observed Bank Swallow may be using the nearby Dundas Street West bridge or an adjacent slope. Regardless, the on-site bluffs will be retained and protected, providing potential future habitat for this species.

#### 5.3.2 SAR Bats

A bat habitat (snag) assessment was completed within the Fresh-Moist Willow Lowland Deciduous Forest (FOD7-3) on June 27, 2025 (**Figure 2**) in areas adjacent to the proposed development. Based on the MNR (2022) protocol, only snags/cavity trees >25 cm DBH should be considered.

A total of five potentially suitable maternity roost trees were observed with DBH ranging from approximately 31 – 86 cm. However, only one of these five are proposed to be removed as it is at the woodland edge and poses a safety concern. It should be noted that only trees adjacent to



the proposed development were assessed, as they may need to be removed. Based on the assessment, additional potential habitat trees will be present in the FOD7-3 and FOD6-1 areas of the Subject Site but would not be affected by development.

The snag attributes consist of cavities, cracks, woodpecker holes and/or peeling bark. Snags in healthy or early stage of decay (Decay Class 1 - 3) may be preferred by Little Brown Myotis and Northern Myotis (Ministry of Natural Resources and Forestry, 2017). All five of the potential snag trees were observed in this decay class range (**Table 4**).

**Table 4: Potential Bat Habitat Trees ≥25 cm DBH Adjacent to Proposed Development**

Tree No.	Scientific Name	Common Name	DBH (cm)	Decay Class*	Height Class**	Snag Attributes	Remove or Retain
85	<i>Fraxinus</i> sp.	Dead Ash	55	3	3	Some cracks/ loose bark above 2 m, good habitat potential but a safety concern	Remove – Condition
109	<i>Salix</i> sp.	Willow Species	52	2	2	Best potential habitat tree adjacent to development (cracks/ loose bark above 2 m)	Retain
202	<i>Salix euxina</i>	Crack Willow	86	2	2	Some habitat Potential (Cracks)	Retain
220	<i>Fraxinus</i> sp.	Dead Ash	38	3	3	Cracks all at Base	Retain
223	<i>Fraxinus</i> sp.	Dead Ash	31	3	3	Cracks in bark above 2 m	Retain

\*Decay Class: 1 – Healthy, live tree; 2 – Declining live tree, part of canopy lost; 3 – Very recently dead, no canopy, bark intact, branches intact; 4 – Recently dead, bark peeling, only large branches intact; 5 – older dead tree, 90% of bark lost, few branch stubs, broken top; 6 – very old dead tree, advanced decay, no branches, parts of stem have rotted away

\*\*Height Class: Dominant (1) – above canopy; Co-dominant (2) – canopy height; Intermediate (3) – just below canopy; Suppressed (4) – well below canopy height

### 5.3.3 SAR Fish

The Credit River lies adjacent to the Site. Both American Eel and Lake Sturgeon (Great Lakes - Upper St. Lawrence River population) (*Acipenser fulvescens*) may migrate past the Subject Site. It is noted that the records of Lake Sturgeon are considered historical. There are no anticipated direct impacts to the Credit River.

### 5.3.4 Snapping Turtle

No Snapping Turtle was observed during species-specific surveys, but an individual was incidentally observed in 2014 in the abandoned swimming pool. Turtle is a Species of Special Concern, which is not afforded species or habitat protection under the SCA. Consideration regarding Significant Wildlife Habitat is discussed below (Section 5.4).



## 5.4 Significant Wildlife Habitat

Significant Wildlife Habitat (SWH) is addressed in Provincial, Regional, and Municipal policies. It is defined by the MNRF in the Significant Wildlife Habitat Technical Guide (Ontario Ministry of Natural Resources, 2000), and includes the following broad categories:

- seasonal concentration areas;
- rare vegetation communities or specialised habitats for wildlife;
- habitats of species of conservation concern, excluding the habitats of endangered and threatened species; and
- animal movement corridors.

Similar to Dougan's 2017 SWH screening, SLR did not identify SWH types within the Subject Site (**Appendix E**). Criteria for the identification of these features are provided in the Significant Wildlife Habitat Criteria Schedules for Ecoregion 7E (Ontario Ministry of Natural Resources and Forestry, 2015). The 2009 Peel-Caledon Significant Woodlands and Significant Wildlife Habitat Study (North-South Environmental Inc., Dougan & Associates and Sorensen Gravely Lowes, 2009) was reviewed, but no additional information or criteria was deemed relevant to the Subject Site. While the Peel-Caledon study contemplates locally rare flora species, there are no definitive criteria lists for these species. Note that preservation of the woodland and bluff ELC types will preserve the locations these species were observed in (Section 4.5, **Figure 2**).

The field surveys did indicate the presence of potential SWH indicator species, including Bank Swallow and Northern-rough Winged Swallow; Snapping Turtle; and presence of potential bat habitat roost trees.

While both Bank Swallow and Northern-rough winged swallows were observed foraging in the area, the 2025 surveys demonstrated that there was no evidence of nesting on the bluff portions of the Subject Site, and the Colonially-nesting Bird Breeding Habitat (Bank and Cliff) SWH type is not present.

Suitable natural habitat for Snapping Turtle is absent. The abandoned pool is a non-natural structure and does not support habitat conditions for suitable Turtle Wintering Area, and does not provide the sandy soils needed for nesting. Based on observations of the pool, it would also appear to be very difficult for turtles to exist in the pool given the steep vertical concrete perimeter as is typical with a constructed pool. Therefore, SWH types required for habitats for this Special Concern species are not present on the Subject Site.

The bat habitat surveys did indicate the presence of potential roost trees that may support individual SAR bats (Section 5.3.2). However, given the limited area of the tree cover and the linear nature of the remnant woodland, the Subject Site is not believed to support Bat Maternity Colonies SWH habitat.

## 6.0 Proposed Development

The proposed development includes a high-rise building consisting of a six-storey podium and a 12-storey tower, a stacked townhouse complex, and three levels of underground parking (**Figure 3**).

The proposed site access is deemed to be a necessary and reasonable alternative to the existing site access because the existing site access at 2955 Mississauga Rd is deemed unsafe and not functional because it is too close to the intersection with Dundas Street. The proposed site access was formally an established access to the 2935 Mississauga Road and remains as



an opening in the forest canopy cover. For these reasons, this is the most feasible access to the property. The site access is proposed to be wider than the former site access to allow for two-way traffic. Restoration of the former access will limit this impact on the woodland and provide for maintained connectivity.

The development limit was determined based on several environmental constraints associated with the Subject Site; woodland, Significant Woodland, Significant Valleyland, and Regional Floodplain (**Figure 3**). Given the complicated history associated with past land use and occupancy of the site, the proponent has directed that the development limit be established based on the current site conditions.

The Significant Valleyland is proposed to be protected with a 6 m setback (Beacon, 2020) and the woodlands located on the south and western property limits are proposed to be protected with a variable distance setback, averaging 10 m, which is detailed in Section 7.2. This setback will be restored with a *native, self-sustaining vegetation* plan, as detailed in the project landscape plan (Aboud and Associates Inc., 2026). The natural features will be further setback by landscape plantings, which while designated as landscaping, and will make use of native species for most of their composition.

Greck and Associates (Greck) has been engaged as part of the project team to review the hazard assessment associated with the regional floodplain. The following regional floodplain analysis was prepared by Greck:

Historical site alterations [the Salt Creek Spillway] have significantly reduced contributing flows to the channel which is now described as an ephemeral naturalized drainage swale, and as such the floodline through the Subject Site is conservatively based on flood elevations originating from the Credit River which back up into the historical channel outlet. Greck have delineated the 2005 Golder floodline on the December 10, 2019 topographic mapping from the local land surveyor Tarasick McMillan Kubisick Limited (TMK). Greck has paired the floodplain with a 0.3 m freeboard line based on hydraulic modelling from the Credit River (**Figure 3**). The regulatory flood elevation is delineated through the Subject Site on 2019 topographic mapping prepared by TMK. The flood elevation is derived from CVC approved floodplain mapping for this section of the Credit River, which was prepared by Golder Associates, 2005.

In accordance with provincial policy, all proposed development should be located outside of the 0.3m freeboard line. Given the flood elevations associated with the historical channel are based on backwater from the Credit River, any proposed fill should be compensated with an equivalent cut. However, it should be recognized that any fill impacts would have an insignificant impact on the main Credit River as this particular channel can be considered an ineffective flow area after its truncation years ago.

Therefore, the Regional flood limit associated with the ephemeral naturalized drainage channel is proposed to be protected with 0.3 m freeboard setback as determined by Greck (**Figure 3**).



GIS PATH: G:\Projects\209\209\_065271\_2935\_2955\_MississaugaRa11\_Workspace1\_Maps\20250703\_Ecology\Figures\203\_065271\_EIS\_Figures\apx\_11\_209\_065271-3-6\_Constraints and Opportunities

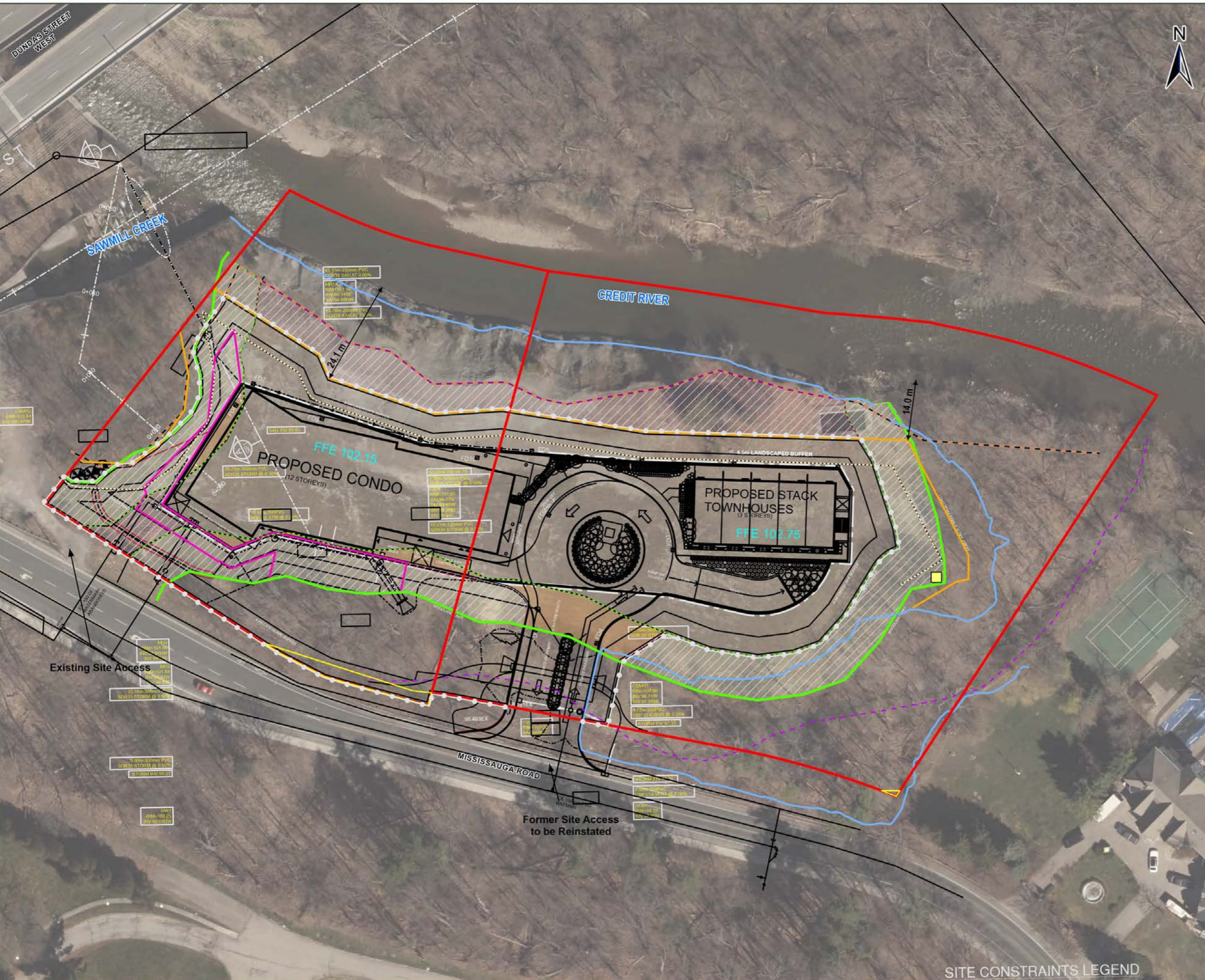

**LEGEND:**

- SUBJECT SITE (2.13 HA)
- FUTURE ROW ALLOCATION
- WOODLAND LIMIT (DELINEATED ON-SITE BY PALMER, FEB 2020)
- EROSION HAZARD LIMIT/LONG TERM STABLE TOP OF SLOPE
- 6 M HAZARD SETBACK
- STAKED TOP OF BANK - APPROVED BY CVC (FEB 2020)
- REVISED 100 YEAR FLOODLINE<sup>1</sup>
- SITE PLAN
- SERVICING PLAN
- PROPOSED CHAIN FENCE
- 10 M THEORETICAL WOODLAND SETBACK (0.32 HA)
- ENCROACHMENT AREA (0.05 HA)
- VARIABLE WOODLAND BUFFER FEATURE (0.41 HA)**
  - WOODLAND BUFFER (0.41 HA)
  - MEADOW TREATMENT (0.06)
  - ADDITIONAL RESTORATION AREA (0.12 HA)
- PROPOSED BAT BOX LOCATION

**NOTES:**  
 1 - GRECK AND ASSOCIATES  
 SERVICE LAYER CREDITS: PEEL REGION2020

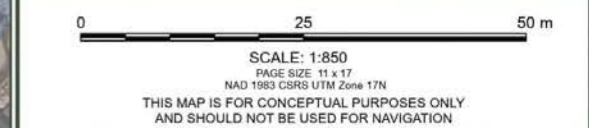

590816 ONTARIO INC. C/O G. MERULLA INC.  
 2935 & 2955 MISSISSAUGA RD  
 MISSISSAUGA ON

2935 & 2955 MISSISSAUGA RD - 2025

**CONSTRAINTS AND OPPORTUNITIES**

**SLR** FIGURE NO:  
**3**

## 7.0 Impact Assessment and Mitigation Measures

The proposed development will require a limited amount vegetation clearing within the Subject Site, for incorporation of stormwater management infrastructures and the reinstatement of the former driveway to Mississauga Road for site access (**Figure 3**). The existing site access at 2955 Mississauga Road is proposed to be decommissioned and will become part of the naturalized setback area (**Figure 3**). The removal of trees may have a limited impact on SAR bat habitat. Other impacts to SAR and wildlife are predicted to be limited; however, mitigations and best practices are outlined. The potential for the introduction of invasive species is also discussed.

The following impact assessment and mitigation measures have been prepared based on and coordinated with the proposed site plan, grading plan and stormwater management plan.

### 7.1 Vegetation Removal

The removal of some forest edge vegetation is proposed to re-instate the former site access, and install the subsurface stormwater chamber and the outfall (**Figure 3**). The Arborist Report for the project details that 35 trees require removal to accommodate the project (SLR, 2026). These proposed works will involve the removal of common trees and shrub species that were present at the edge of the old access lane or that have regenerated into the clearing over time.

The proposed vegetation removal should be completed outside of the C2 nesting zone migratory bird period from early April to later August (Government of Canada, 2025). In general, tree removal should also be conducted outside of the bat maternity roosting period from April 1 to November 30, to account for both resident and migratory bat species (Section 7.6).

As vegetation removal is limited and the woodland and bluff ELC types will be retained, this strategy preserves the habitats locally rare and uncommon species were observed in (Section 4.5, **Figure 3**). Buffers and Restoration Areas (Section 7.2) will serve to protect and extend these habitats.

### 7.2 Variable Buffer and Additional Restoration Areas

The Fresh-Moist Sugar Maple – Lowland Ash Deciduous Forest (FOD6-1) and Fresh-Moist Willow Lowland Deciduous Forest (FOD7-3) are identified as a Core Area of the Region's Greenlands System. For Core Areas, Mississauga Official Plan policy 6.3.8 states that *buffers will be determined on a site-specific basis as part of an Environmental Impact Study or other similar study to the satisfaction of the City and appropriate conservation authority.*

The term "buffer" refers to an area of land neighbouring natural features that are alongside lands that are planned to undergo site alteration or development. The purpose of the buffer is to protect the ecological functions and features of the natural feature by reducing, mitigating, or eliminating potential impacts from site alteration or the proposed development. The buffer width depends on the sensitivity of the feature being protected and the proposed land use, and consists of natural vegetation of variable widths.

A buffer that varies in overall width (i.e., greater than 10 m in some areas and less than 10 m in others) that is an average of 10 m wide has been proposed for the Project. This is a similar width to those prescribed by other municipalities and is consistent with CVC's regulatory requirements. The 10 m buffer distance takes into consideration the natural heritage features and functions to be protected and required buffer functions, as well as enhancement and mitigation opportunities within the buffer. To ensure the buffer distances are appropriate, they



were compared to the *Ecological Buffer Guideline Review* completed for southern Ontario (Beacon, 2012).

### 7.2.1 Net Gain in Buffer Area

Due to site development constraints, a “variable” buffer distance has been proposed that is 10 m on average (**Figure 3**). If a consistent (theoretical) 10 m buffer was applied to the woodlands, it would provide a 0.32 ha buffer area. However, 0.05 ha of minor encroachments are required to accommodate the proposed development and Site Access. Therefore, a “variable” buffer and additional restoration area was proposed. This area (**Figure 3**) provides 0.41 ha of buffer and restoration area, providing a 0.09 ha net gain over a consistent 10 m buffer distance.

There are some additional infrastructure features that are required to be within the buffer area, as the design team has determined that there are no other viable locations. These include a subsurface stormwater infiltration chamber and a stormwater outlet. Upon receipt of comments from the City and CVC, the outlet has been relocated to avoid erosion risks and slope hazards (Greck, 2025). Both the infiltration chamber and outlet piping are below surface features, and the area will be vegetated with native species as part of the buffer.

### 7.2.2 Native Species Restoration

Native species plantings are proposed to be implemented in the buffer to protect the woodland feature from the proposed development with the variable buffer approach. Buffer plantings are expected to adequately protect the feature from the proposed adjacent land uses (**Figure 3**). The variable buffer is composed of three types of area, all of which will be planted with *native, self-sustaining vegetation*; the planting plans are detailed in the *Landscape Plan (LP-1 to LP-7) - 2935-2955 Mississauga Road* (Aboud and Associates Inc., 2026). In its design, the Landscape Plan has considered the *CVC Ecosystem Offsetting Guideline* (Credit Valley Conservation Authority, 2020), and the *CVC Guidelines for Designing Enhancement Plans Within Setbacks and Buffers* (Credit Valley Conservation Authority, 2023). The restoration and landscaping areas provide trees far in excess of the 196 required in compensation for those removed (SLR, 2026).

Two of those areas, the woodland buffer and additional restoration area, include tree and shrub covers which will extend the woodland cover, providing 0.35 ha of treed cover, which is still in excess of the 0.32 ha the “theoretical” buffer would provide. The 0.06 ha Meadow Treatment area is proposed to be vegetated by only a native ground cover seed mix. This will allow for occasional maintenance of the infiltration chamber and outlet, but will also provide for limited tree cover along the façade of the building, in accordance with the principles for Bird Friendly Design (Section 7.7).

It should also be noted that the buffer areas will be fringed by a more typical landscaping area (Aboud and Associates Inc., 2026). While a more varied species mix is planned for this landscaping, many native species are included in this design, and will continue to expand the green spaces adjacent to the proposed development.

### 7.2.3 Buffer Function Effectiveness

With implementation of the plans herein, the variable distance woodland buffer is considered to be appropriate to mitigate impacts to the woodland functions and balance the objectives of the proposed development while maintaining the functional requirements of the buffer (i.e., protection of the adjacent feature). The variable woodland buffer (10 m average) falls within ranges evaluated to provide adequate buffering for screening for human disturbance and changes in land use, and core habitat protection (Beacon, 2012). The variable woodland buffer



(10 m average) also generally provides for a hazard mitigation zone, as most trees would be anticipated to fall within that limit.

While human presence and activity will increase in the area, the presence of highly trafficked Mississauga Road has already likely limited the wildlife use and ecological function of that specific wooded area. The variable woodland buffer will provide an edge management area for the current wooded areas, eventually extending the potential habitats that they provide. The reinstated access (Section 7.3) will be offset, as the existing access will be restored. Restoration of this access will maintain or improve woodland connectivity, joining the Salt Creek Spillway treed areas and extending along the Credit River Bluffs in the long term.

For the area adjacent to the Credit River, appropriate watercourse setbacks have been established in accordance with the City of Mississauga Official Plan, the CVC Watershed Planning and Regulation Policies, and applicable Provincial hazard identification guidelines. The distance from the surveyed “Edge of Water” (typical water level) to the Long-Term Stable Top of Slope (LTSTOS) along the Credit River and Sawmill Creek ranges from approximately 14 m to 24.1 m (**Figure 3**). In addition, an erosion hazard safety setback of 6 m has been applied beyond the LTSTOS.

The Additional Restoration Area adjacent to the Credit River ranges from approximately 5 m to 15 m, and comprises approximately 0.12 ha, to be planted with native vegetation consistent with CVC and City restoration objectives. The City’s Natural Heritage and Urban Forest Strategy establishes a long-term target of achieving 30 m of naturally vegetated land on both sides of 75% of City watercourses by 2033. The primary purpose of this strategy is to ensure that the City NHS is protected, enhanced, restored and expanded to the greatest extent feasible on both private and public lands, while still recognizing the need to accommodate continued growth and economic growth in this urban landscape.

While a continuous 30 m vegetated buffer cannot be achieved across the entire frontage of the Subject Lands due to existing topographic constraints, hazard limits, and established buffers to these features, the proposed development meets the intent of the Strategy by:

- Protecting all regulated valley lands, erosion and flood hazards, and required setbacks in accordance with CVC and City policy;
- Adding restored NHS area to support ecological features and functions;
- The restoration will enhance and extend ecological function, improve riparian habitat, and increase natural cover;
- Improving connectivity and linkages of the NHS corridors for plants and wildlife;
- Providing cooling and food sources for aquatic habitats;
- Ultimately contributing to the resilience of the City’s natural heritage system over time.

Collectively, the distance from the “Edge of Water” including the proposed Additional Restoration Area and setbacks result in an effective vegetated corridor of approximately 20 m to 30 m in width along portions of the watercourses, which is consistent with the objectives of the Natural Heritage and Urban Forest Strategy and represents a context-sensitive implementation of its intent.

### **7.3 Woodland Connectivity and the Reinstated Site Access**

The access to 2955 Mississauga Road is proposed to be reinstated as the access for the development. While this area has been identified as a Significant Woodland, and development



is to be generally avoided per Mississauga Official Plan policy 6.3.26. However, OP policy 6.3.27 states that *Development and site alteration as permitted in accordance with the Greenlands designation within or adjacent to a Significant Natural Area will not be permitted unless all reasonable alternatives have been considered and any negative impacts minimized. Any negative impact that cannot be avoided will be mitigated through restoration and enhancement to the greatest extent possible.*

In assessing alternative access points, the use of the existing open access at 2935 Mississauga Road has been considered for this project. However, from a traffic safety perspective it has been determined to be too close to the Mississauga Road and Dundas Street West intersection. Reinstatement of the former access presents the next most reasonable access point, as it presents a limited impact compared to new clearing.

The narrow portion of the woodland feature adjacent to the north side of Mississauga Rd is considered a lower functioning linear treed area (i.e., functioning similar to a hedgerow), and as such, the proposed reinstatement of the site access would result in limited changes to the woodland feature and its functions. The woodland vegetation community is currently bisected by the anthropogenic opening where the former site access was located and tree cover remains limited (Beacon, 2020). Reinstating this access is expected to slightly encroach into existing woodland edge. Nevertheless, the woodland units of the FOD7-3 community are expected to remain connected from a functional perspective given the narrowness of the proposed site access. Hardscape portions of the reinstated site access is proposed to be approximately 15 m wide and woodland connectivity is considered to be maintained where canopy gaps are less than 20 m wide, per general guidance from Provincial technical documents such as the Oak Ridges Moraine Conservation Plan (ORMCP) *Technical Paper 7 - Identification and Protection of Significant Woodlands* (Ontario Ministry of Municipal Affairs and Housing, N.D.). The proposed reinstated site access is proposed to be culverted and constructed in a manner that will maintain and/or improve flows through the Ephemeral Naturalized Drainage Swale. With the exception of maintaining the conveyance of very intermittent flows along the swale, there is limited ecological connectivity for such a narrow treed feature along a regional road. Thus, no negative impacts are expected as a result of the reinstated site access.

Following policy 6.3.27, in the northwest of the site, the existing open access point will be restored as part of the development plan (**Figure 3**) and Landscape Plan (Aboud and Associates Inc., 2026). This restoration will provide a connection between the FOD7-3 woodland and the CUW1 at the Sawmill Creek storm outlet. This will further be reconnected to the overall woodland via the Additional Naturalization Area along the Credit River. Restoration of the Additional Naturalization Area will similarly improve connectivity along the northern portion of the subject lands. In this way, connectivity of woodland features is maintained and enhanced.

### 7.3.1 Wildlife Connectivity – Culvert Design

The proposed culvert design will function as a wildlife permeable crossing structure consistent with *CVC Fish and Wildlife Crossing Guidelines* (Credit Valley Conservation Authority, 2017). The culvert design is a 1350 mm concrete culvert, 19.8 m long (**Figure 3**, but also Servicing Plan drawing SP1). This meets the minimum design requirements for the safe passage of small terrestrial and semi-aquatic wildlife. The design provides:

- An Openness Ratio of 0.72, being >0.1, or at minimum 0.07 for amphibians, snakes, and small mammals
- A width/height of 1.35 m, exceeding the minimum of 0.31 m for small mammals, and



- A width/height of 1.35 m, being >1.0 m for amphibians and reptiles, and a length of 19.8 m, meeting the preferred length of <25 m.

## 7.4 Artificial Pool Removal

The existing pool is considered to potentially result in the loss of wildlife. Although turtles have been observed in the pool, they may become trapped when water levels lower because the cement sides are too steep to climb out (**Photo 2**).

The pond is also covered by a mat of Common Duckweed (*Lemna minor*), which grows in stagnant or slow-moving bodies of water. It can become a problem when it covers too much of a water surface, as it can block sunlight from reaching other aquatic plants and disrupt the balance of the ecosystem (U.S. Forest Service, 2025). It is thought that the single observation of a turtle in the pool was likely an incidental event where the individual turtle was seeking open water. However, as can be seen in **Photo 2**, it would be very difficult or not even possible for a turtle to exit the pool for extended periods of time due to the vertical concrete perimeter of the pool. It is our opinion that there is no habitat function associated with the pool and it may in fact represent a risk to the turtles as they may become trapped.

Therefore, the existing pool is proposed to be removed to avoid detrimental wildlife use and safety precautions. The removal of the pool should be completed during fall or winter months to avoid the active amphibian and reptile period that spans from early April to late September. If the pool is to be removed outside of this period, this would require an inspection by a ecologist/biologist to ensure any wildlife is safely relocated.



**Photo 2: Abandoned Pool, showing steep sides and Common Duckweed mat.**

## 7.5 Aquatic Species Mitigation

There is the potential for the adjacent Credit River to host American Eel, and to a lesser potential, Lake Sturgeon (Section 5.3.3). The project has been setback from the Long-Term



Stable Slope that defines the Credit River (**Figure 3**). As such, there are no predicted direct impacts on the watercourse or aquatic species.

To minimize the potential for erosion and off-site transportation of sediment into surface water features (i.e. the Credit River) and the natural environment, the project will implement best management practices (BMP) related to ESC measures. In general, ESC measures should be installed before works commencing and be maintained in good condition for the duration of the works. ESC measures must meet guidelines outlined in the *Erosion Sediment Control Guide for Urban Construction* (Toronto and Region Conservation Authority, 2019). With respect to ESC measures, the contractor must:

- Retain existing vegetation and stabilize ground with native vegetation where possible;
- Limit the duration of soil exposure and/or phase construction;
- Delimit the perimeter of excavation area with light-duty silt fencing;
- Maintain overland sheet flow and avoid concentrating flow;
- Store and stockpile soil away from natural drainage features and drainage structures; and
- Assess ESC measures before and after significant rainfall and snowmelt events.

All repairs required to ESC measures will be completed within 48 hours of notice unless otherwise agreed by the City, the Contractor, the regulatory authority and the environmental inspector(s). Stockpiles are to be protected immediately and, if placed for longer than 30 days, temporarily stabilized. ESC fencing should be paired with Tree Protection Fencing wherever possible. ESC fencing should remain in place until landscaping including the Additional Naturalized Area (**Figure 3**) has established.

## 7.6 Bat Habitat Potential

An evaluation of bat habitat characteristics within the proposed new access road and retained woodland was completed during 2025 surveys. Of the trees surveyed that must be removed, Tree #85 demonstrates some bat habitat potential (e.g., holes, cracks, peeling bark). Tree #85 is a dead ash tree due to EAB infestation, and presents a safety concern to the development (**Figure 3**). However, other trees to be retained displayed potential habitat features, of which Tree #109 (a large Willow) displayed the greatest potential. Other dead Ash may also present opportunities, of which Trees #223 and #220 showed the most potential.

As only one potential habitat tree must be removed, and there is evidence of other higher quality roost opportunities in the area that will be retained, the proposed development is not considered to present a demonstrable impact to potential SAR bat habitats.

Regardless, best practices are to be implemented as a conservative measure to avoid and mitigate potential impacts to bat habitats, including timing windows, setback restoration, and interim bat habitat creation. These measures include:

- Avoiding tree clearing from April 1 to November 30, to account for all bat species.
- Providing additional habitat opportunities in the long term, by providing restored setbacks and additional restoration area (Section 7.2, **Figure 3**).
- As an interim measure as the restoration areas develop, a bat “rocket box” is proposed to be constructed in the Additional Restoration Area, adjacent to the Credit River where it would be in closer proximity to water and feeding opportunities (**Figure 3; Appendix F**).



## 7.7 Bird Friendly Design

The project team is committed to providing bird friendly designs and glazing, to be incorporated into the building envelope and design at the detailed design and Site Plan Application stage. Toward that end, relevant strategies have been reviewed (City of Markham, 2013; City of Toronto, 2016; American Bird Conservancy, 2019). Bird-Friendly Design measures are to be applied on the first 16 metres of elevation above grade.

### 7.7.1.1 Lighting

To provide bird-friendly design, lighting considerations for proposed development should be directed towards the development, and be shielded on the woodland side of the lighting.

### 7.7.1.2 Glass Design

The reviewed sources recommend limiting windows to 25 – 40% of the total façade; the current design is not a glass tower and will easily meet this target. Consultation with the project design team confirms that the following glass design recommendations can also be implemented as appropriate at the Site Plan application stage:

- Employ awnings or overhangs to provide shading and visual avoidance clues.
- Unique exterior structures including screens, grilles, louvers, shutters, closely-spaced mullions, and sunshades can also provide visual avoidance clues.
- The use of tinting, frit, film or acid-etched patterns can indicate glass as a solid object to avoid. These should be applied to the exterior surface of exposed windows. Considered creatively, these can become an aesthetic feature of the building.
- The use of opaque, translucent, UV glass or low reflective glass should be considered. Mirrored glass should be avoided.
- The above window treatments should be applied at minimum to 85% of the windows 0 – 16 m above grade (an average mature tree canopy) and to 4 m above any windows above or adjacent to rooftop vegetation.

Landscape Design recommendations include:

- Limit landscaping adjacent to ground-floor windows to low shrubs and ground cover
- Conversely, tree massings adjacent to buildings should be against non-reflective surfaces.
- Minimize fruit-bearing vegetation near windows.
- Elements such as sculptures and low walls can aid in building avoidance.
- interior greenery should be located well away from windows. Where not possible, exterior treatments are recommended.

## 7.8 Invasive Species Management Plan

Non-native species and highly invasive species are not abundant within the Study Site, and their introduction should be avoided. To reduce the potential for invasive species establishment in construction-disturbed areas, these areas should be seeded as soon as possible using the seed mix recommended (Aboud and Associates Inc., 2026). Certified weed-free topsoils and materials should be used to make up any shortfall in fill materials.



### 7.8.1 Construction Equipment

To prevent the spread of invasive species, construction equipment should arrive at the site clean and leave the site clean.

- Before arriving on site, construction equipment should be pressured washed with high-pressure steam-cleaning methods.
- Equipment cleaning stations should be established to ensure that invasive species seeds and other viable plant parts cannot escape in runoff or through other means.
- During construction, equipment used in areas with an abundance of invasive species should be cleaned prior to moving to another portion of the site.
- A high-pressure steam-cleaning should also be completed on vehicles prior to leaving the site.

### 7.8.2 Equipment Cleaning Stations

Equipment should be cleaned in an area where contamination and seed spread are not possible (or limited) (Ontario Invasive Plant Council, 2013). The site should be:

- Ideally, mud free, gravel covered or a hard surface. If this option is not available, choose a well maintained (i.e., regularly mowed) grassy area.
- Gently sloping to assist in draining water and material away from the vehicle or equipment. Care should be taken to ensure that localized erosion will not be created, and that water runs back into the area where contamination occurred.
- A means of collecting equipment washings and adding them to soils destined for landfills should be integrated into standard construction practices.
- Cleaning stations should be at least 30 m away from any watercourse, water body and natural vegetation.
- Cleaning stations should be large enough to allow for adequate movement of larger vehicles and equipment.

## 8.0 Policy Conformity

A summary of applicable natural heritage policies and the manner in which the proposed development plan meets their requirements is provided in **Table 5** below. Section 7 demonstrates the manner in which the proposed development will avoid or appropriately mitigate for most natural features. The proposed development will require the reinstated access to cross the Subject Site woodland at Mississauga Road, but will also be mitigated and offset, and conforms to relevant policy, as described below.

**Table 5: Policy Conformity**

Policy Document	Policy Intent/Objective	Implications and Policy Conformity
<i>Migratory Birds Convention Act</i>	Protect most species of migratory birds and their nests and eggs anywhere they are found in Canada.	Vegetation removal should be completed between early September and late March of any given year. Biologist to screen for nest for any proposed vegetation removal outside of this period.



Policy Document	Policy Intent/Objective	Implications and Policy Conformity
<i>Species Conservation Act</i>	Species and the habitat of species designated as Endangered or Threatened are afforded legal protection.	<p>SAR and SAR habitat this is known to be within or directly adjacent to the Subject Site are proposed to be retained and protected.</p> <p>Studies demonstrated that while SAR bird species were observed as flyovers, nesting habitats were not present onsite.</p> <p>The removal of one potential bat maternity roost tree is proposed, but is not felt to provide a measurable impact, as other higher potential trees will remain. Timing Windows will be respected for tree removals. Trees that will develop into roost potential will be planted in the proposed setback areas. Should MECP require additional mitigation (e.g., Bat Boxes), this will be implemented at Site Plan Control.</p> <p>While no direct impacts to aquatic SAR are anticipated, ESC measures (Section 7.5) will ensure that habitats are also not impacted.</p>
Provincial Planning Statement	Direction to regional and local municipalities regarding planning policies for the protection and management of natural heritage features.	<p>The proposed development will reinstate the former access within the woodland; however, the naturalization of the current access will offset this, ensuring that the woodland and its ecological functions will be maintained.</p> <p>No development or site alteration is proposed within other existing, defined natural heritage features and the ecological functions will be maintained.</p>
Region of Peel Official Plan	Core Areas: Development is generally prohibited within Core Areas.	The reinstated site access will be constructed through the woodland Core Area. Per policy 2.3.2.6, development and site alteration generally prohibited within Core Areas, however, per the policy, the project demonstrates that there is no reasonable alternative location outside of the Core Area and the use, it is limited to the extent possible; and that through naturalization of the existing access and the buffers, the impact to Core Area features is minimized and mitigated through restoration and enhancement.
City of Mississauga Official Plan	The City's Green System is comprised of the NHS, Urban Forest, Natural Hazard Lands, and Parks and Open Spaces. Buffers are determined on a site-specific basis as part of the EIS.	<p>Following policies 6.3.26 and 6.3.27, no development is proposed in the existing limits of the woodland designated as Core Area with the exception for a reinstated site access. The proposed site access is deemed to be a necessary and reasonable alternative to the existing site access.</p> <p>Woodland buffers on the Subject Site will be enhanced with native plantings following the completion of nearby grading works.</p>



Policy Document	Policy Intent/Objective	Implications and Policy Conformity
		Specific policies have also been commented on and reviewed in Section 7, as relevant.
O. Reg. 160/06	CVC regulates activities in and adjacent to water, natural areas, and hazardous areas.	CVC's policies for buffers and setbacks are proposed to be implemented, including a variable buffer (10 m average) to a Significant Woodland and 6 m setback to flood and erosion hazards.

## 9.0 Conclusions

The findings of this updated EIS are the result of a background review, 2019 and 2025 field investigations, air photo review, compilation of data from the 2017 Dougan and Associates EIS, and an analysis of data using current scientific understanding of the ecology of the area, as well as current natural heritage policy.

We have identified natural environmental sensitivities, constraints and development opportunities for the Subject Site based on the current site conditions. The environmental constraints consist of various natural heritage features and respective buffers or setbacks in accordance with planning and regulatory policies and guidelines.

## 10.0 Closure

This report was prepared, reviewed and approved by the undersigned:

Regards,

**SLR Consulting (Canada) Ltd.,**



**Austin Adams, M.Sc., EP**  
Technical Director – Arboriculture,  
Sr. Ecologist



**Dirk Janas, B.Sc.**  
Technical Director – Terrestrial Ecology,  
Sr. Ecologist



## 11.0 References

- About and Associates Inc. (2026). *Landscape Plan (LP-1 to LP-7) - 2935-2955 Mississauga Road*.
- American Bird Conservancy. (2019). *Bird-Friendly Building Design*. Retrieved from [https://abcbirds.org/wp-content/uploads/2019/04/Bird-Friendly-Building-Design\\_Updated-April-2019.pdf](https://abcbirds.org/wp-content/uploads/2019/04/Bird-Friendly-Building-Design_Updated-April-2019.pdf)
- Beacon. (2012). *Ecological Buffer Guideline Review*. Beacon Environmental Ltd.
- Beacon Planning Services. (2020). *Planning Justification and Rational Report Prepared in Support of Proposed Development at 2935 & 2955 Mississauga Road*.
- Bird Studies Canada. (2009). *Marsh Monitoring Program Participant's Handbook for Surveying Amphibians*. Retrieved from naturecounts.ca: [https://naturecounts.ca/resources/mmp/Handbook\\_MMP\\_Amphibians\\_2022refreshed.pdf](https://naturecounts.ca/resources/mmp/Handbook_MMP_Amphibians_2022refreshed.pdf)
- Bird Studies Canada. (2021). *Ontario Breeding Bird Atlas Guide for Participants - Point Counts*. Retrieved from <https://birdsonario.b-cdn.net/wp-content/uploads/Instructions-for-Point-Counts-June-2021.pdf>
- Chapman, L. J., & Putnam, D. F. (1984). *The Physiography of Southern Ontario - Third Edition. Ontario*.
- City of Markham. (2013). *Bird Friendly Guidelines*. North-South Environmental Inc. Retrieved from <http://www2.markham.ca/markham/ccbs/indexfile/Agendas/2013/Development%20Services/pl131022/Markham%20Draft%20Bird%20Friendly%20Guidelines%20October%202013.pdf>
- City of Mississauga. (2011, May 15). *City of Mississauga Official Plan (May 15, 2025 Consolidation)*. Retrieved from mississauga.ca: <https://www.mississauga.ca/projects-and-strategies/strategies-and-plans/mississauga-official-plan/>
- City of Mississauga. (2021). *Natural Areas Survey*. Retrieved from [mississauga.maps.arcgis.com](https://mississauga.maps.arcgis.com/): <https://mississauga.maps.arcgis.com/apps/MapSeries/index.html?appid=2103d1a57cf044a3ab801950bc174686&entry=17>
- City of Toronto. (2016). *Bird-friendly Best Practices - Glass*. Retrieved from <https://www.toronto.ca/wp-content/uploads/2017/08/8d1c-Bird-Friendly-Best-Practices-Glass.pdf>
- Credit Valley Conservation Authority. (2002). *Plants of the Credit River Watershed*. Retrieved from Credit Valley Conservation Authority: <https://cvc.ca/wp-content/uploads/2011/01/PlantsComplete.pdf>
- Credit Valley Conservation Authority. (2017). *Fish and Wildlife Crossing Guidelines*. Retrieved from [cvc.ca: https://cvc.ca/wp-content/uploads/2017/05/CVC-Fish-and-Wildlife-Crossing-Guidelines-final-web.pdf](https://cvc.ca/wp-content/uploads/2017/05/CVC-Fish-and-Wildlife-Crossing-Guidelines-final-web.pdf)
- Credit Valley Conservation Authority. (2020). *Ecosystem Offsetting Guideline*. Retrieved from [cvc.ca: https://files.cvc.ca/cvc/uploads/2021/06/rpt\\_CVCEcoOffset\\_FINAL\\_20200313.pdf](https://files.cvc.ca/cvc/uploads/2021/06/rpt_CVCEcoOffset_FINAL_20200313.pdf)



- Credit Valley Conservation Authority. (2023). *Guidelines for Designing Enhancement Plans Within Setbacks and Buffers*. Retrieved from [www.cvc.ca](http://www.cvc.ca): <https://cvc.ca/document/57660/>
- Crins, W. J., Gray, P. A., Uhlig, P. W., & Wester, M. C. (2009). *The Ecosystems of Ontario, Part 1: Ecozones and Ecoregions*. Peterborough, Ontario: Ontario Ministry of Natural Resources. Retrieved from <https://www.ontario.ca/page/ecosystems-ontario-part-1-ecozones-and-ecoregions>
- Dougan and Associates. (2017). *Environmental Impact Study. Merulla Properties. 2935 & 2955 Mississauga Road, City of Mississauga*.
- Fisheries and Oceans Canada. (2025). *Aquatic Species at Risk Map*. Retrieved from Fisheries and Oceans Canada: <http://www.dfo-mpo.gc.ca/species-especes/sara-lep/map-carte/index-eng.html>
- Government of Canada. (1994). Migratory Birds Convention Act, 1994 (S.C. 1994, c. 22). Retrieved from <http://laws-lois.justice.gc.ca/eng/acts/m-7.01/>
- Government of Canada. (2023). *Beneficial Management Practices - Avoiding Harm to Migratory Birds*. Retrieved from [canada.ca](https://www.canada.ca/en/environment-climate-change/services/avoiding-harm-migratory-birds/beneficial-management-practices.html): <https://www.canada.ca/en/environment-climate-change/services/avoiding-harm-migratory-birds/beneficial-management-practices.html>
- Government of Canada. (2025). *Nesting Zones*. Retrieved from Government of Canada - Environment and Climate Change: [https://www.canada.ca/en/environment-climate-change/services/avoiding-harm-migratory-birds/general-nesting-periods/nesting-periods.html#\\_zoneC\\_calendar](https://www.canada.ca/en/environment-climate-change/services/avoiding-harm-migratory-birds/general-nesting-periods/nesting-periods.html#_zoneC_calendar)
- Government of Ontario. (2007). Endangered Species Act, 2007, S.O. 2007, c. 6. Retrieved from <https://www.ontario.ca/laws/statute/07e06>
- Government of Ontario. (2025). *Land Information Ontario*. Retrieved from [ontario.ca](https://www.ontario.ca/page/land-information-ontario): <https://www.ontario.ca/page/land-information-ontario>
- Government of Ontario. (2025). *O. Reg. 230/08: Species at Risk in Ontario List*. Retrieved from [ontario.ca](https://www.ontario.ca/laws/regulation/080230): <https://www.ontario.ca/laws/regulation/080230>
- Government of Ontario. (2026, March 30). Species Conservation Act, 2025, S.O. 2025, c. 4, Sched. 10.
- Kaiser, J. (2001). *The Vascular Plant Flora of the Region of Peel and the Credit Watershed*.
- Lee, H. T., Bakowsky, W. D., Riley, J., Bowles, J., Puddister, M., Uhlig, P., & McMurray, S. (1998). *Ecological Land Classification for Southern Ontario: First Approximation and its Application*. Ontario Ministry of Natural Resources, Southcentral Science Section, Science Development and Transfer Branch.
- MGP. (2026, October). Planning Opinion Letter.
- Ministry of Municipal Affairs and Housing. (2024). *Provincial Planning Statement, 2024*. Retrieved from [ontario.ca](https://www.ontario.ca/page/provincial-planning-statement-2024): <https://www.ontario.ca/page/provincial-planning-statement-2024>
- Ministry of Natural Resources and Forestry. (2022). *Maternity Roost Surveys (Forests/Woodlands)*.
- Ministry of Natural Resources and Forestry. (2017). *Survey Protocol for Species at Risk Bats within Treed Habitats: Little Brown Myotis, Northern Myotis & Tri-Colored Bat*. Guelph: Ministry of Natural Resources and Forestry - Guelph District.



- Ministry of Natural Resources and Forestry. (2018). *Natural Heritage Information Request Guide*. Ministry of Natural Resources and Forestry.
- Ministry of Natural Resources and Forestry. (2025). *Natural Heritage Information Centre*. Retrieved from Ministry of Natural Resources and Forestry: <https://www.ontario.ca/page/natural-heritage-information-centre>
- Ministry of Natural Resources and Forestry. (2025). *Natural Heritage Information Centre Species Lists*. Retrieved from Ministry of Natural Resources and Forestry: <https://www.ontario.ca/page/get-natural-heritage-information>
- North-South Environmental Inc., Dougan & Associates and Sorensen Gravely Lowes. (2009). *Peel-Caledon Significant Woodlands and Significant Wildlife Habitat Study*. Prepared for the Region of Peel and the Town of Caledon. Retrieved from <https://www.peelregion.ca/planning/officialplan/pdfs/Peel-CaledonSW-SWH-Study-Report-Part4.pdf>
- Ontario Invasive Plant Council. (2013). *Clean Equipment Protocol for Industry*. Retrieved from [ontarioinvasiveplants.ca](https://www.ontarioinvasiveplants.ca): [https://www.ontarioinvasiveplants.ca/wp-content/uploads/2016/07/Clean-Equipment-Protocol\\_June2016\\_D3\\_WEB-1.pdf](https://www.ontarioinvasiveplants.ca/wp-content/uploads/2016/07/Clean-Equipment-Protocol_June2016_D3_WEB-1.pdf)
- Ontario Ministry of Municipal Affairs and Housing. (2017). *Greenbelt Plan (2017)*. Retrieved from Ministry of Municipal Affairs and Housing: <http://www.mah.gov.on.ca/Page13783.aspx>
- Ontario Ministry of Municipal Affairs and Housing. (N.D.). *Oak Ridges Moraine Conservation Plan Technical Paper 7: Identification and Protection of Significant Woodlands*. Retrieved from Government of Ontario: <http://www.mah.gov.on.ca/AssetFactory.aspx?did=4892>
- Ontario Ministry of Natural Resources. (2000). *Significant Wildlife Habitat Technical Guide*. Peterborough: Queen's printer for Ontario. Retrieved from <https://www.ontario.ca/document/guide-significant-wildlife-habitat>
- Ontario Ministry of Natural Resources and Forestry. (2013). *Milksnake Survey Protocol*. Guelph District.
- Ontario Ministry of Natural Resources and Forestry. (2015). *Significant Wildlife Habitat Criteria Schedules For Ecoregion 7E*. Peterborough: Regional Operations Division, Southern Region Resources Section.
- Ontario Nature. (2019). *Ontario Reptile and Amphibian Atlas*. Retrieved from Ontario Nature: <https://ontarionature.org/programs/citizen-science/reptile-amphibian-atlas/>
- Palmer. (2020). *Fluvial Geomorphology Review. 2935 & 2955 Mississauga Road*.
- Parish Aquatic Services. (2016). *Geomorphic Review Assessment of Pre-diversion Sawmill Creek Corridor: 2955 & 2935 Mississauga Road*.
- Region of Peel. (2022). *Region of Peel Official Plan. April 2022 Consolidation*. Retrieved from Region of Peel: [https://www.peelregion.ca/officialplan/download/\\_media/region-of-peel-official-plan-april2022.pdf](https://www.peelregion.ca/officialplan/download/_media/region-of-peel-official-plan-april2022.pdf)
- SLR. (2026). *Updated Arborist Report - 2935 & 2955 Mississauga Road, City of Mississauga\_Rev E*. SLR Consulting (Canada) Ltd.
- Terraprobe. (2008). *Geotechnical Investigation Slope Stability and Streambank Erosion Analysis. 2935 and 2955 Mississauga Road. Mississauga, Ontario*.



Terraprobe. (2010). *Addendum, Geotechnical Investigation. 2935 and 2955 Mississauga Road. Mississauga, Ontario.*

Toronto and Region Conservation Authority. (2019). *Erosion and Sediment Control Guide For Urban Construction.* Retrieved from [https://s3-ca-central-1.amazonaws.com/trcaca/app/uploads/2020/01/30145157/ESC-Guide-for-Urban-Construction\\_FINAL.pdf](https://s3-ca-central-1.amazonaws.com/trcaca/app/uploads/2020/01/30145157/ESC-Guide-for-Urban-Construction_FINAL.pdf)

Toronto Entomologists Association. (2019). *Ontario Butterfly Atlas.* Retrieved from <https://www.ontarioinsects.org/atlas/part2.html>

U.S. Forest Service. (2025). *Common duckweed (Lemna minor).* Retrieved from [www.fs.usda.gov/wildflowers/](http://www.fs.usda.gov/wildflowers/): [https://www.fs.usda.gov/wildflowers/plant-of-the-week/lemna\\_minor.shtml](https://www.fs.usda.gov/wildflowers/plant-of-the-week/lemna_minor.shtml)





# Appendix A Agency Correspondence

## Updated Environmental Impact Study

2935 & 2955 Mississauga Road, City of Mississauga

**590816 Ontario Inc.**

SLR Project No.: 209.065271.00001

April 28, 2026



Natalie Dunn &lt;natalie.dunn@pecg.ca&gt;

---

**RE: Proposed TOR for 2935&2955 Mississauga Road**

1 message

**Ashlee Rivet** <Ashlee.Rivet@mississauga.ca>

Tue, Nov 26, 2019 at 2:14 PM

To: Natalie Dunn &lt;natalie@pecg.ca&gt;

Cc: "Maricris.Marinac@cvc.ca" &lt;Maricris.Marinac@cvc.ca&gt;, Michael Hynes &lt;Michael.Hynes@mississauga.ca&gt;

Hi Natalie,

The original email with the draft TOR was sent by Angela. If I remember correctly, this is now your file.

Attached are CVC's comments on the TOR. Community Services comments include:

- *Please ensure that the City of Mississauga's Natural Areas Survey factsheet for the site is referenced in the background review section and that the site is discussed in the context of Mississauga's Natural Heritage System.*
- *Can you also ensure that the applicant has received Mississauga's EIS terms of reference checklist (attached)?*

Any specific questions regarding these comments should be directed to the reviewer directly and copy me.

Thanks,

**Ashlee Rivet-Boyle BES, MCIP, RPP**

Planner, Development South

T 905-615-3200 ext.5751

[ashlee.rivet@mississauga.ca](mailto:ashlee.rivet@mississauga.ca)[City of Mississauga](#) | Planning and Building Department

Development and Design Division

Please consider the environment before printing.

---

**From:** Angela Wallace [mailto:[angela@pecg.ca](mailto:angela@pecg.ca)]  
**Sent:** Friday, June 14, 2019 1:51 PM  
**To:** [Maricris.Marinis@cvc.ca](mailto:Maricris.Marinis@cvc.ca)  
**Cc:** Dirk Janas; Ashlee Rivet; Frank Merulla; [planning@cvc.ca](mailto:planning@cvc.ca); Robin McKillop; Eric Greck  
**Subject:** Proposed TOR for [2935&2955 Mississauga Road](#)

Hi Maricris,

Attached, please find a proposed Environmental Impact Study Terms of Reference (TOR) for [2935 & 2955 Mississauga Road](#).

Please review this TOR and provide us with any comments or clarifications.

Please contact me at 647-795-8153 ext. 159 or [angela@pecg.ca](mailto:angela@pecg.ca) if you have any questions.

Thank you for your time.

Angela

**Angela Wallace**  
Senior Aquatic Ecologist

**Palmer Environmental Consulting Group Inc.**  
74 Berkeley Street, Toronto, ON M5A 2W7  
t 647 795 8153 ext 159 c 647 242 7207 e [angela@pecg.ca](mailto:angela@pecg.ca)  
[www.pecg.ca](http://www.pecg.ca)

----- Forwarded message -----

From: "Marinas, Maricris" <[Maricris.Marinis@cvc.ca](mailto:Maricris.Marinis@cvc.ca)>  
To: Ashlee Rivet <[Ashlee.Rivet@mississauga.ca](mailto:Ashlee.Rivet@mississauga.ca)>  
Cc:  
Bcc:  
Date: Thu, 14 Nov 2019 15:55:27 +0000  
Subject: 2935-2955 Miss Rd., EIS TOR Comments

Hi Ashlee,

As you are aware, there is a long history on these subject lands and throughout CVC has consistently provided guidance that the appropriateness and extent of any proposed development requires achieving regulatory and policy requirements including the restoration and rehabilitation of (unauthorized) disturbed portions of the site.

It is with this understanding that CVC staff provide the following comments with regards to the EIS TOR (attached):

## COMMENTS

1. The subject property is entirely within the City of Mississauga's designated Green System (Natural Heritage System – significant natural area and natural green space, and Natural Hazards) and Core Area (environmentally significant area, significant woodlands, significant valleyland and fish habitat) of the Region of Peel's Greenlands System.

Please include a Policy Review section in the background review to identify all relevant planning policies and regulations; all municipal, regional and provincial designations; significant natural features; and, appropriate setbacks to these features. Both the City of Mississauga and Region of Peel's official Plans contain policies restricting development within, and adjacent to, these areas. Replacement and rehabilitation of ecological features and functions is required by the Region of Peel's Official Plan (2.3.2.7) where those have been damaged or destroyed.

2. Please refer to Region of Peel's Core Greenlands System mapping and related Official Plan policies to ensure the site and any proposed development is assessed and discussed in context with these.
3. Please include the review of historic aerial photography to identify the extent and ecological composition of pre-disturbance conditions on the subject property to inform the development of a site restoration plan.
4. Please provide a site restoration plan that will outline the extent of site restoration and the measures that will be taken to restore soil conditions, natural site gradients, and natural heritage features within the restoration area.
5. Please note two breeding bird survey visits is preferred to occur within a study year to attain the highest level of breeding status as possible for resident species, as per Ontario Breeding Bird Atlas protocols.
6. Please complete the screening for SAR bats in the SAR and SWH Screening exercises.

Further to the above, and for context, it maybe helpful to have a look at the attached memo which was provided as evidence for past proceedings.

Should you have any questions, please do not hesitate to contact me.

Regards,

Maricris

**Maricris Marinas, M.Sc.**

Senior Planner, Planning and Development Services | Credit Valley Conservation

905-670-1615 ext 220 | 1-800-668-5557

**NEW:** [maricris.marinas@cvc.ca](mailto:maricris.marinas@cvc.ca) | [cvc.ca](http://cvc.ca)

The information contained in this Credit Valley Conservation electronic message is directed in confidence solely to the person(s) named above and may not be otherwise distributed, copied or disclosed including attachments. The message may contain information that is privileged, confidential and exempt from disclosure under the Municipal Freedom of Information and Protection and Privacy Act and by the Personal Information Protection Electronic Documents Act. The use of such personal information except in compliance with the Acts, is strictly prohibited. If you have received this message in error, please notify the sender immediately advising of the error and delete the message without making a copy. Thank you.

---

**4 attachments****PECG Proposed EIS TOR 2935-2955 Mississauga Rd 14June2019.pdf**

159K

**scan\_14042\_2019-11-14-10-41-54.pdf**

14501K

**2935-2955 Miss Rd., EIS TOR Comments.eml**

20090K

**Mississauga EIS Checklist\_Draft 2017.pdf**

598K



# Appendix B Flora List and Air Photo Review

## Updated Environmental Impact Study

2935 & 2955 Mississauga Road, City of Mississauga

590816 Ontario Inc.

SLR Project No.: 209.065271.00001

April 28, 2026

Scientific Name	Common Name	NHIC Provincial Rank	SARO Status	Local Status (Native Sp. Only)			Dougan 2017	Palmer 2019/SLR 2025			
				Peel	Mississauga	CVC		CUW1	ANTH / CUM1	FOD7-3	FOD6-1
<i>Acer negundo</i>	Manitoba Maple	S5					x	x		x	x
<i>Acer nigrum</i>	Black Maple	S4?					x				
<i>Acer platanoides</i>	Norway Maple	SNA					x	x		x	
<i>Acer saccharinum</i>	Silver Maple	S5					x				
<i>Acer saccharum</i>	Sugar Maple	S5					x	x		x	x
<i>Achillea millefolium</i>	Common Yarrow	SNA					x		x		
<i>Aegopodium podagraria</i>	Goutweed	SNA					x			x	
<i>Alliaria petiolata</i>	Garlic Mustard	SNA					x	x		x	x
<i>Amelanchier arborea</i>	Downy Serviceberry	S5			2		x				
<i>Amelanchier laevis</i>	Smooth Serviceberry	S5					x				
<i>Amelanchier spicata</i>	Running Serviceberry	S4		R3		Local Rare	x				
<i>Anemone quinquefolia</i>	Wood Anemone	S5					x				x
<i>Anemone virginiana</i>	Tall Thimbleweed	S5									x
<i>Antennaria howellii</i>	Howell's Pussytoes	S5					x				
<i>Antennaria sp.</i>	Pussytoes Species						x				
<i>Apocynum androsaemifolium</i>	Spreading Dogbane	S5			2		x				
<i>Arctium lappa</i>	Great Burdock	SNA					x				
<i>Arctium minus</i>	Common Burdock	SNA					x		x		
<i>Arenaria serpyllifolia</i>	Thyme-leaved Sandwort	SNA					x				
<i>Arisaema triphyllum</i>	Jack-in-the-pulpit	S5					x			x	
<i>Artemisia vulgaris</i>	Common Wormwood	SNA							x		
<i>Aruncus dioicus</i>	Common Goatsbeard	SNA							x		
<i>Asclepias syriaca</i>	Common Milkweed	S5					x		x		
<i>Asparagus officinalis</i>	Garden Asparagus	SNA					x				
<i>Aster sp.</i>	Aster Species						x		x	x	x
<i>Berberis thunbergii</i>	Japanese Barberry	SNA					x				x
<i>Berberis x ottawensis</i>	( <i>Berberis thunbergii</i> X <i>Berberis vulgaris</i> )	SNA					x				
<i>Betula papyrifera</i>	Paper Birch	S5					x		x		
<i>Betula pendula</i>	Weeping Birch	SNA					x				
<i>Bidens frondosa</i>	Devil's Beggar-ticks	S5								x	
<i>Bromus inermis</i>	Smooth Brome	SNA					x		x		
<i>Cardamine concatenata</i>	Cut-leaved Toothwort	S5					x				
<i>Carex aurea</i>	Golden Sedge	S5		U	2		x				
<i>Carex blanda</i>	Woodland Sedge	S5					x				
<i>Carex pensylvanica</i>	Pennsylvania Sedge	S5					x				
<i>Carex sp.</i>	Sedge Species						x			x	x
<i>Carex spicata</i>	Spiked Sedge	SNA					x				
<i>Catalpa speciosa</i>	Northern Catalpa	SNA						x			
<i>Cichorium intybus</i>	Wild Chicory	SNA					x		x		

Peel (Kaiser, 2001): Rx = number of locations in Region. U = Uncommon in Region.

Mississauga (Mississauga, 2021): 1 = 1 to 3 locations in City, considered regionally significant. 2 = 4 to 10 locations in the City.

CVC: (CVC, 2002) – LR = Locally Rare

Scientific Name	Common Name	NHIC Provincial Rank	SARO Status	Local Status (Native Sp. Only)			Dougan 2017	Palmer 2019/SLR 2025			
				Peel	Mississauga	CVC		CUW1	ANTH / CUM1	FOD7-3	FOD6-1
<i>Circaea canadensis</i>	Broad-leaved Enchanter's Nightshade	S5					x	x		x	x
<i>Cirsium arvense</i>	Canada Thistle	SNA					x		x	x	
<i>Cirsium sp.</i>	Thistle Species						x				
<i>Claytonia virginica</i>	Eastern Spring Beauty	S5					x				
<i>Convallaria majalis</i>	European Lily-of-the-valley	SNA					x				
<i>Cornus alternifolia</i>	Alternate-leaf Dogwood	S5									x
<i>Cornus racemosa</i>	Grey Dogwood	S5					x		x		
<i>Cornus rugosa</i>	Round-leaved Dogwood	S5					x				
<i>Cornus sericea</i>	Red-osier Dogwood	S5					x	x			
<i>Cornus sp.</i>	Dogwood Species										
<i>Crataegus crus-galli</i>	Cockspur Hawthorn	S4					x				
<i>Crataegus sp.</i>	Hawthorn Species						x			x	
<i>Cryptotaenia canadensis</i>	Canada Honewort	S5			2		x				
<i>Dactylis glomerata</i>	Orchard Grass	SNA					x		x		x
<i>Daucus carota</i>	Wild Carrot	SNA					x		x		
<i>Dipsacus fullonum</i>	Common Teasel	SNA					x		x		
<i>Elymus canadensis</i>	Canada Wildrye	S5									
<i>Elymus repens</i>	Quackgrass	SNA					x				
<i>Elymus riparius</i>	Eastern Riverbank Wildrye	S4					R3	1	Local Rare	x	
<i>Epipactis helleborine</i>	Broad-leaved Helleborine	SNA									x
<i>Equisetum arvense</i>	Field Horsetail	S5					x				
<i>Erigeron philadelphicus</i>	Philadelphia Fleabane	S5					x		x		
<i>Erythronium americanum</i>	Yellow Trout-lily	S5					x				
<i>Euonymus alatus</i>	Winged Euonymus	SNA					x			x	
<i>Euphorbia esula</i>	Leafy Spurge						x				
<i>Fagus grandifolia</i>	American Beech	S4					x				
<i>Fragaria virginiana</i>	Wild Strawberry	S5					x		x		
<i>Fraxinus americana</i>	White Ash	S4					x	x	x	x	x
<i>Fraxinus excelsior</i>	European Ash	SNA					x				
<i>Fraxinus pennsylvanica</i>	Red Ash	S4					x				x
<i>Galium sp.</i>	Bedstraw species										x
<i>Geranium maculatum</i>	Spotted Geranium	S5					U			x	x
<i>Geranium robertianum</i>	Herb-Robert	S5								x	x
<i>Geum aleppicum</i>	Yellow Avens	S5					x				x
<i>Geum laciniatum</i>	Rough Avens	S4					x				
<i>Geum macrophyllum</i>	Large-leaved Avens	S5					x				
<i>Geum sp.</i>	Avens Species						x				
<i>Glechoma hederacea</i>	Ground-ivy	SNA					x			x	
<i>Hesperis matronalis</i>	Dame's Rocket	SNA					x		x		

Peel (Kaiser, 2001): Rx = number of locations in Region. U = Uncommon in Region.

Mississauga (Mississauga, 2021): 1 = 1 to 3 locations in City, considered regionally significant. 2 = 4 to 10 locations in the City.

CVC: (CVC, 2002) – LR = Locally Rare

Scientific Name	Common Name	NHIC Provincial Rank	SARO Status	Local Status (Native Sp. Only)			Dougan 2017	Palmer 2019/SLR 2025			
				Peel	Mississauga	CVC		CUW1	ANTH / CUM1	FOD7-3	FOD6-1
<i>Hordeum jubatum</i>	Foxtail Barley	S5?							X		
<i>Hydrophyllum virginianum</i>	Virginia Waterleaf	S5					X			X	
<i>Hypericum perforatum</i>	Common St. John's-wort	SNA					X		X		
<i>Impatiens capensis</i>	Spotted Jewelweed	S5					X			X	
<i>Juglans nigra</i>	Black Walnut	S4?					X	X		X	X
<i>Juniperus virginiana</i>	Eastern Red Cedar	S5							X		
<i>Lapsana communis</i>	Common Nipplewort	SNA								X	
<i>Leonurus cardiaca</i>	Common Motherwort	SNA							X		
<i>Leucanthemum vulgare</i>	Oxeye Daisy	SNA					X		X		
<i>Ligustrum vulgare</i>	European Privet	SNA					X			X	
<i>Lonicera tatarica</i>	Tatarian Honeysuckle	SNA					X	X	X	X	X
<i>Lotus corniculatus</i>	Garden Bird's-foot Trefoil	SNA					X		X		
<i>Maianthemum racemosum</i>	Large False Solomon's Seal	S5					X				X
<i>Maianthemum sp.</i>	Solomon's Seal Species						X				
<i>Maianthemum stellatum</i>	Star-flowered False Solomon's Seal	S5			2		X				
<i>Malus sp.</i>	Apple Species						X		X		
<i>Medicago lupulina</i>	Black Medick	SNA					X		X		
<i>Melilotus albus</i>	White Sweet-clover	SNA					X		X		
<i>Melilotus officinalis</i>	Yellow Sweet-clover	SNA					X				
<i>Nepeta cataria</i>	Catnip	SNA					X				
<i>Ostrya virginiana</i>	Eastern Hop-hornbeam	S5					X			X	X
<i>Oxalis stricta</i>	Upright Yellow Wood-sorrel	S5									X
<i>Parthenocissus quinquefolia</i>	Virginia Creeper	S4?					X				
<i>Parthenocissus vitacea</i>	Thicket Creeper	S5					X			X	
<i>Penthorum sedoides</i>	Ditch Stonecrop	S5					X				
<i>Phleum pratense</i>	Common Timothy	SNA					X				
<i>Picea abies</i>	Norway Spruce	SNA					X				
<i>Picea glauca</i>	White Spruce	S5				R3	X		X		
<i>Pilosella caespitosa</i>	Meadow Hawkweed	SNA							X		
<i>Pilosella piloselloides ssp. praealta</i>	King Devil Hawkweed	SNA					X				
<i>Pinus nigra</i>	Austrian Pine	SNA					X				
<i>Pinus strobus</i>	Eastern White Pine	S5					X		X		
<i>Pinus sylvestris</i>	Scots Pine	SNA					X	X	X		
<i>Plantago lanceolata</i>	English Plantain	SNA							X		
<i>Plantago major</i>	Common Plantain	SNA					X				
<i>Poa compressa</i>	Canada Bluegrass	SNA					X				
<i>Poa pratensis</i>	Kentucky Bluegrass	S5					X		X		
<i>Podophyllum peltatum</i>	May-apple	S5					X				
<i>Populus balsamifera</i>	Balsam Poplar	S5					X				
<i>Populus deltoides</i>	Eastern Cottonwood	S5					X	X	X	X	

Peel (Kaiser, 2001): Rx = number of locations in Region. U = Uncommon in Region.

Mississauga (Mississauga, 2021): 1 = 1 to 3 locations in City, considered regionally significant. 2 = 4 to 10 locations in the City.

CVC: (CVC, 2002) – LR = Locally Rare

Scientific Name	Common Name	NHIC Provincial Rank	SARO Status	Local Status (Native Sp. Only)			Dougan 2017	Palmer 2019/SLR 2025			
				Peel	Mississauga	CVC		CUW1	ANTH / CUM1	FOD7-3	FOD6-1
<i>Populus grandidentata</i>	Large-toothed Aspen	S5					x				
<i>Populus tremuloides</i>	Trembling Aspen	S5					x				
<i>Potentilla recta</i>	Sulphur Cinquefoil	SNA					x		x		
<i>Prunella vulgaris</i>	Common Self-heal	S5					x				
<i>Prunus avium</i>	Sweet Cherry	SNA					x				
<i>Prunus serotina</i>	Black Cherry	S5					x				x
<i>Prunus virginiana</i>	Chokecherry	S5					x			x	x
<i>Quercus alba</i>	White Oak	S5					x				
<i>Quercus macrocarpa</i>	Bur Oak	S5					x				
<i>Quercus rubra</i>	Northern Red Oak	S5					x				x
<i>Quercus velutina</i>	Black Oak	S4		R3	2	Local Rare	x				
<i>Ranunculus abortivus</i>	Kidney-leaved Buttercup	S5					x				
<i>Ranunculus acris</i>	Common Buttercup	SNA					x				x
<i>Ranunculus ficaria</i>	Fig-root Buttercup	SNA					x				
<i>Reynoutria japonica</i>	Japanese Knotweed	SNA					x	x			
<i>Rhamnus cathartica</i>	European Buckthorn	SNA					x			x	x
<i>Rhus typhina</i>	Staghorn Sumac	S5					x		x		
<i>Ribes sp.</i>	Currant Species						x			x	x
<i>Ribes triste</i>	Swamp Red Currant	S5		U	2		x				
<i>Robinia pseudoacacia</i>	Black Locust	SNA					x				
<i>Rosa multiflora</i>	Multiflora Rose	SNA					x				
<i>Rosa sp.</i>	Rose Species						x	x	x	x	x
<i>Rubus idaeus ssp. strigosus</i>	North American Red Raspberry	S5					x				
<i>Rubus occidentalis</i>	Black Raspberry	S5					x		x	x	x
<i>Rubus odoratus</i>	Purple-flowering Raspberry	S5					x			x	
<i>Rumex crispus</i>	Curled Dock	SNA					x		x	x	
<i>Rumex sp.</i>	Dock Species						x				
<i>Salix alba</i>	White Willow	SNA					x				
<i>Salix fragilis (S. euxina)</i>	Crack Willow						x				
<i>Salix sp.</i>	Willow Species						x			x	
<i>Sanguinaria canadensis</i>	Bloodroot	S5					x			x	
<i>Scilla siberica</i>	Siberian Squill	SNA					x				
<i>Securigera varia</i>	Purple Crown-vetch	SNA					x		x		
<i>Silene vulgaris</i>	Bladder Campion	SNA					x				
<i>Solanum dulcamara</i>	Bittersweet Nightshade	SNA					x			x	
<i>Solidago altissima</i>	Tall Goldenrod	S5					x				
<i>Solidago caesia</i>	Blue-stemmed Goldenrod	S5					x				
<i>Solidago canadensis</i>	Canada Goldenrod	S5					x				
<i>Solidago flexicaulis</i>	Zigzag Goldenrod	S5					x			x	x
<i>Solidago gigantea</i>	Giant Goldenrod	S5					x				

Peel (Kaiser, 2001): Rx = number of locations in Region. U = Uncommon in Region.

Mississauga (Mississauga, 2021): 1 = 1 to 3 locations in City, considered regionally significant. 2 = 4 to 10 locations in the City.

CVC: (CVC, 2002) – LR = Locally Rare

Scientific Name	Common Name	NHIC Provincial Rank	SARO Status	Local Status (Native Sp. Only)			Dougan 2017	Palmer 2019/SLR 2025			
				Peel	Mississauga	CVC		CUW1	ANTH / CUM1	FOD7-3	FOD6-1
<i>Solidago nemoralis</i>	Grey-stemmed Goldenrod	S5					x				
<i>Solidago sp.</i>	Goldenrod Species						x		x	x	x
<i>Symphotrichum cordifolium</i>	Heart-leaved Aster	S5					x				x
<i>Symphotrichum lanceolatum</i>	Panicled Aster	S5					x				
<i>Taraxacum officinale</i>	Common Dandelion	SNA					x		x		x
<i>Thalictrum pubescens</i>	Tall Meadow-rue	S5					x				
<i>Thuja occidentalis</i>	Eastern White Cedar	S5					x		x		
<i>Tilia americana</i>	Basswood	S5					x			x	x
<i>Tilia cordata</i>	Little-leaved Linden	SNA					x				
<i>Toxicodendron radicans</i>	Poison Ivy	S5					x		x	x	x
<i>Tragopogon dubius</i>	Yellow Goatsbeard	SNA					x				
<i>Trifolium repens</i>	White Clover	SNA					x		x		
<i>Tsuga canadensis</i>	Eastern Hemlock	S5					x				
<i>Tussilago farfara</i>	Coltsfoot	SNA					x				
<i>Ulmus americana</i>	White Elm	S5					x			x	x
<i>Ulmus pumila</i>	Siberian Elm	SNA					x		x		
<i>Urtica dioica</i>	Stinging Nettle	S5					x			x	
<i>Verbascum thapsus</i>	Common Mullein	SNA					x		x		
<i>Veronica officinalis</i>	Common Speedwell	SNA					x			x	
<i>Veronica persica</i>	Bird's-eye Speedwell	SNA					x				
<i>Viburnum acerifolium</i>	Maple-leaved Viburnum	S5					x				
<i>Viburnum opulus</i>	Cranberry Viburnum	S5					x			x	
<i>Viburnum sp.</i>	Viburnum Species						x				
<i>Vicia cracca</i>	Tufted Vetch	SNA					x		x		
<i>Viola cucullata</i>	Marsh Blue Violet	S5				R6	x				
<i>Viola sp.</i>	Violet Species						x				
<i>Vitis riparia</i>	Riverbank Grape	S5					x		x	x	x

Peel (Kaiser, 2001): Rx = number of locations in Region. U = Uncommon in Region.

Mississauga (Mississauga, 2021): 1 = 1 to 3 locations in City, considered regionally significant. 2 = 4 to 10 locations in the City.

CVC: (CVC, 2002) – LR = Locally Rare

**Photo 1: 1954 Air Photo – University of Toronto**

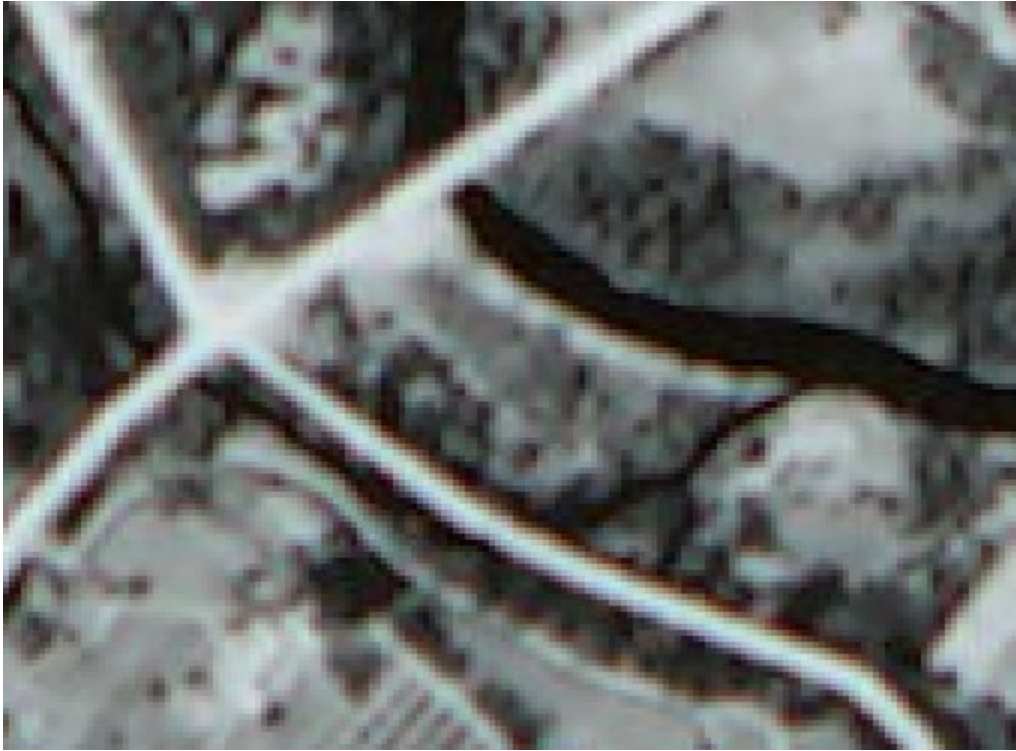

**Photo 2: 1966 Air Photo – Mississauga Maps**

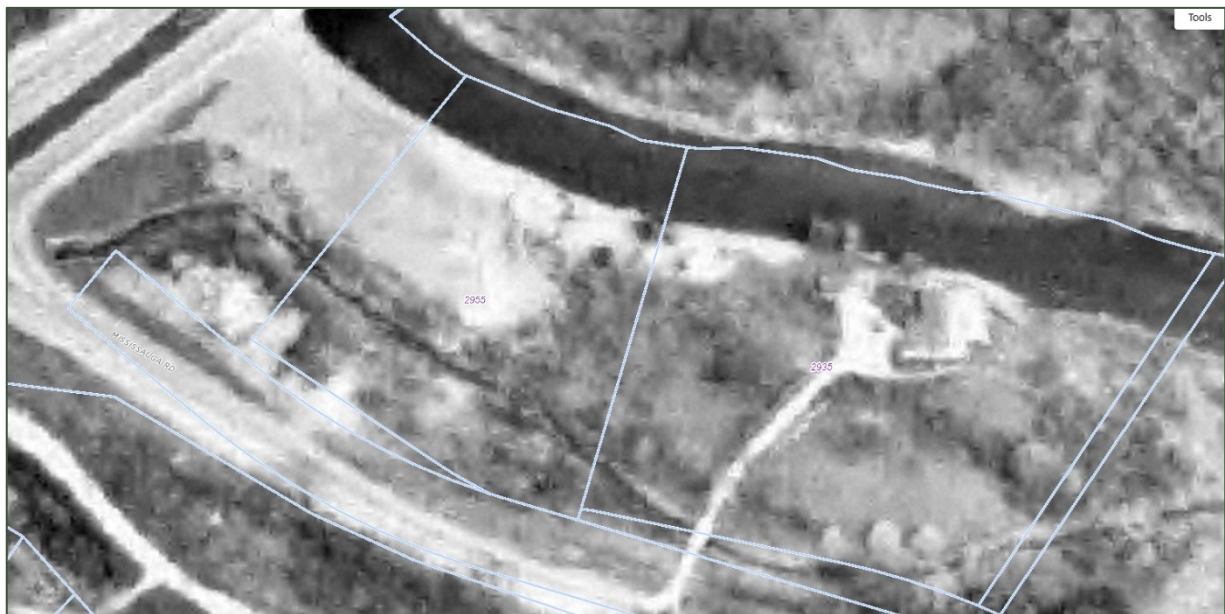

**Photo 3: 2004 (October) – Google Earth**



**Photo 4: 2004 (December) – Google Earth**



**Photo 5: 2006 Air Photo – Mississauga Maps**



**Photo 6: 2007 (March) – Google Earth**



**Photo 7: 2009 (August) – Google Earth**



**Photo 8: 2018 (July) – Google Earth**



**Photo 9: 2025 (March) – Google Earth**





# Appendix C Breeding Bird Survey Results

## Updated Environmental Impact Study

2935 & 2955 Mississauga Road, City of Mississauga

590816 Ontario Inc.

SLR Project No.: 209.065271.00001

April 28, 2026

Common Name	Scientific Name	SARO	S Rank	Area Sensitivity	Breeding Evidence	Surveys				
						26-05-14	09-06-14	14-06-19	10-06-25	27-26-25
Mallard	<i>Anas platyrhynchos</i>		S5	---	CONFIRMED	1X	5H, 5FY		1H	
Common Loon	<i>Gavia immer</i>		S5	---	OBSERVED	2X	1X			
Great Blue Heron	<i>Ardea herodias</i>		S4	---	OBSERVED		1X	1X		
Red-tailed Hawk	<i>Buteo jamaicensis</i>		S5	---	POSSIBLE		1H			
Killdeer	<i>Charadrius vociferus</i>		S5	---	CONFIRMED	2T, 2FY	2T, 2FY		1S	
Spotted Sandpiper	<i>Actitis macularia</i>		S5	---	PROBABLE				1S	2T
Ring-billed Gull	<i>Larus delawarensis</i>		S5	---	OBSERVED		R			
Belted Kingfisher	<i>Megaceryle alcyon</i>		S4	---	PROBABLE		1P			
Downy Woodpecker	<i>Dryobates pubescens</i>		S5	---	POSSIBLE					1S
Northern Flicker	<i>Colaptes auratus</i>		S4	---	PROBABLE	2H, 1P	1H			1S
Eastern Kingbird	<i>Tyrannus tyrannus</i>		S4	---	POSSIBLE	1H			2S	
Red-eyed Vireo	<i>Vireo olivaceus</i>		S5	---	PROBABLE	1S	1T	1S		
Blue Jay	<i>Cyanocitta cristata</i>		S5	---	PROBABLE	1H	1S, 2H	1S	1S	1T
American Crow	<i>Corvus brachyrhynchos</i>		S5	---	POSSIBLE		1S, 1H			
Northern Rough-winged Swallow	<i>Stelgidopteryx serripennis</i>		S4	---	POSSIBLE	4H	4H		13H	7H
Bank Swallow	<i>Riparia riparia</i>	THR	S4	---	POSSIBLE	6H	2H	6X		
White-breasted Nuthatch	<i>Sitta carolinensis</i>		S5	AS	POSSIBLE	1S				1S
House Wren	<i>Troglodytes aedon</i>		S5	---	POSSIBLE	1S				

Common Name	Scientific Name	SARO	S Rank	Area Sensitivity	Breeding Evidence	Surveys				
						26-05-14	09-06-14	14-06-19	10-06-25	27-26-25
American Robin	<i>Turdus migratorius</i>		S5	---	PROBABLE	1P, 1S, 1H		3S	1S	2T
Gray Catbird	<i>Dumetella carolinensis</i>		S4	---	PROBABLE	1H	1T	1S		1S
Cedar Waxwing	<i>Bombycilla cedrorum</i>		S5	---	PROBABLE				1S	1T
European Starling	<i>Sturnus vulgaris</i>		SNA	---	POSSIBLE	1H		2S		
Song Sparrow	<i>Melospiza melodia</i>		S5	---	PROBABLE	2S	2T, 1S	2S	3S	2T
Northern Cardinal	<i>Cardinalis cardinalis</i>		S5	---	PROBABLE	2S	2S		2S	1T
Red-winged Blackbird	<i>Agelaius phoeniceus</i>		S4	---	PROBABLE	3H	R	1X	5S	6T
Common Grackle	<i>Quiscalus quiscula</i>		S5	---	POSSIBLE		7X			2S
Orchard Oriole	<i>Icterus spurius</i>		S4	---	POSSIBLE				1S	
Baltimore Oriole	<i>Icterus galbula</i>		S4	---	PROBABLE	1S	1T		1S	
American Goldfinch	<i>Spinus tristis</i>		S5	---	PROBABLE	1S		5P	1S	
House Sparrow	<i>Passer domesticus</i>		SE	---	OBSERVED			1X		
Eastern Phoebe	<i>Sayornis phoebe</i>		S5	---	POSSIBLE				1S	
Great Crested Flycatcher	<i>Myiarchus crinitus</i>		S4	---	POSSIBLE			1S		1S
Turkey Vulture	<i>Cathartes aura</i>		S5	---	OBSERVED			2X		
Black-capped Chickadee	<i>Poecile atricapillus</i>		S5	---	POSSIBLE			2S	2S	



# Appendix D Species at Risk Screening

## Updated Environmental Impact Study

2935 & 2955 Mississauga Road, City of Mississauga

**590816 Ontario Inc.**

SLR Project No.: 209.065271.00001

April 28, 2026

## Species at Risk Screening

NAME	SARA STATUS	SARO	COSEWIC	SCHEDULE	S-RANK	HABITAT REQUIREMENTS	SOURCE OF RECORD	HABITAT PRESENT (Y/P/N)	RATIONALE	POTENTIAL IMPACTS AND MITIGATION
<b>AVIFAUNA</b>										
Bank Swallow ( <i>Riparia riparia</i> )	THR	THR	THR	1	S4B	The Bank Swallow is threatened by loss of breeding and foraging habitat, destruction of nesting habitat and widespread pesticide use. Bank swallows are small songbirds with brown upperparts, white underparts and a distinctive dark breast band. It averages 12 cm long and weighs between 10 and 18 grams. The swallow can be distinguished in flight from other swallows by its quick, erratic wing beats and its almost constant buzzy, chattering vocalizations. They nest in burrows in natural and human-made settings where there are vertical faces in silt and sand deposit, including banks of rivers and lakes, active sand and gravel pits or former ones where the banks remain suitable. The birds breed in colonies ranging from several to a few thousand pairs (Ministry of Natural Resources and Forestry, 2014).	NHIC (2025)	No	Present, but not nesting on-site; observed in 2014 and 2019; however, no nesting structures were observed in on-site bluffs, as observed in 2025.	None - no nesting structures observed on the Credit River bluffs on-siteduring BBS surveys.
Barn Swallow ( <i>Hirundo rustica</i> )	THR	SC	SC	1	S4B	The Barn Swallow is found throughout southern Ontario, and can range into the north as long as suitable nesting locations can be found. These birds prefer to nest within human made structures such as barns, bridges, and culverts. Barn Swallow nests are cup-shaped and made of mud; they are typically attached to horizontal beams or vertical walls underneath an overhang. A significant decline in populations of this species has been documented since the mid-1980s, which is thought to be related to a decline in prey. Since the Barn Swallow is an aerial insectivore, this species relies on the presence of flying insects at specific times during the year. Changes in building practices and materials may also be having an impact on this species (Ministry of Natural Resources and Forestry, 2015).	NHIC (2025)	No	Not observed during breeding bird studies. No suitable habitat.	None
Bobolink ( <i>Dolichonyx oryzivorus</i> )	THR	THR	SC	1	S4B	The Bobolink is found in grasslands and hayfields, and feeds and nests on the ground. This species is widely distributed across most of Ontario; however, are designated at risk because of rapid population decline over the last 50 years (Ministry of Natural Resources and Forestry, 2014). The historical habitat of the bobolink was tallgrass prairie and other natural open meadow communities; however, as a result of the clearing of native prairies and the post-colonial increase in agriculture, bobolinks are now widely found in hayfields. Due to their reproductive cycle, nesting habits, and use of agricultural areas, bobolink nests and young are particularly vulnerable to loss as a result of common agricultural practices (i.e. first cut hay).	NHIC (2025)	No	Not observed during breeding bird studies.	None
Eastern Meadowlark ( <i>Sturnella magna</i> )	THR	THR	THR	1	S4B,S3N	The Eastern Meadowlark is a bird that prefers pastures and hayfields, but is also found to breed in orchards, shrubby fields and human use areas such as airports and roadsides. Eastern meadowlarks can nest from early May to mid-August, in nests that are built on the ground and well-camouflaged with a roof woven from grasses. The decline in population of these species is thought to be at least partially related to habitat destruction and agricultural practices (Ministry of Natural Resources and Forestry, 2014).	NHIC (2025)	No	Not observed during breeding bird studies.	None
Eastern Wood-Pewee ( <i>Contopus virens</i> )	SC	SC	SC	1	S4B	The Eastern Wood-pewee is classified as a species of special concern by COSSARO. Their population has been gradually declining since the mid-1960's (The Cornell Lab of Ornithology, 2015). The Eastern Wood-pewee is a "flycatcher", a bird that eats flying insects, that lives in the mid-canopy layer of forest clearings and edges of deciduous and mixed forests. It prefers intermediate-age forest stands with little understorey vegetation. Threats to the population are largely unknown; however, causes may include loss of habitat due to urban development and decreases in the availability of flying insect prey (Ministry of Natural Resources and Forestry, 2014).	NHIC (2025)	No	Not observed during breeding bird studies.	None
Grasshopper Sparrow ( <i>Ammodramus savannarum</i> )	SC	SC	SC	1	S4B	Grasshopper Sparrow are specialized to open relatively short grassland habitat, preferably grasslands with relatively sparse cover such as those in areas of poor soils, including alvars, moraines, and sand plains and generally does not favour tall grass moist meadows. It will also breed in manmade hayfields and occasionally in cereals such as Rye ( <i>Secale cereale</i> ).	NHIC (2025)	No	Not observed during breeding bird studies.	None

NAME	SARA STATUS	SARO	COSEWIC	SCHEDULE	S-RANK	HABITAT REQUIREMENTS	SOURCE OF RECORD	HABITAT PRESENT (Y/P/N)	RATIONALE	POTENTIAL IMPACTS AND MITIGATION
Henslow's Sparrow ( <i>Ammodramus henslowii</i> )	END	END	END	1	S1B	Henslow's Sparrow is found in large fields with tall grass, a dense litter layer, and standing dead vegetation. Continuous patches of grassland of at least 30 hectares are likely required to support Henslow's sparrow populations, which nest and probably feed on the ground. This species is extremely rare in Ontario, and there have been no confirmed breeding occurrences in the province in many years. Habitat management programs have been undertaken in Ontario to increase the area of grassland through shrub removal and mowing. Due to their reproductive cycle, nest habits, and specialized habitat requirements, Henslow's sparrow nests and young are particularly vulnerable to the loss and degradation of moist, grassy habitats (Committee on the Status of Species at Risk in Ontario (COSSARO), 2011).	NHIC (2025)	No	Not observed during breeding bird studies.	None
Wood Thrush ( <i>Hyalocichla mustelina</i> )	THR	SC	THR	1	S4B	The Wood Thrush is a species of Special Concern because of habitat degradation or destruction by anthropogenic development. The Wood Thrush is a medium-sized songbird, generally rusty-brown on the upper parts with white under parts and large blackish spots on the breast and sides, and about 20 cm long. The Wood Thrush forages for food in leaf litter or on semi-bare ground, including larval and adult insects as well as plant material. They seek moist stands of trees with well-developed undergrowth in large mature deciduous and mixed (conifer-deciduous) forests. The Wood Thrush flies south to Mexico and Central America for the winter (Ministry of Natural Resources and Forestry, 2014).	NHIC (2025)	No	Not observed during breeding bird studies.	None
Yellow-breasted Chat ( <i>Icteria virens</i> )	END	END	END	1	S1B	The Yellow-breasted Chat inhabits thickets and scrub, with preference toward overgrown clearings and riparian thickets (Ministry of Natural Resources and Forestry, 2015). The population of Yellow-breasted Chat is concentrated in southern Ontario from the Niagara Peninsula toward Point Pelee National Park; however, isolated occurrences of the species have been documented north of Lake Ontario.	NHIC (2025)	No	Not observed during breeding bird studies.	None
<b>HERPTILES</b>										
Snapping Turtle ( <i>Chelydra serpentina</i> )	SC	SC	SC	1	S4	The snapping turtle is a species of special concern in Ontario due to the potential for the species to become threatened or endangered as a result of biological factors or other identified threats. While not presently protected by law, the snapping turtle has been recognized as a species of special concern by COSSARO. Snapping turtles spend the majority of their lives in water and travel slightly upland to gravel or sandy embankments or beaches to lay their eggs (Ontario Ministry of Natural Resources and Forestry, 2014).	NHIC (2025), MNR/Aurora District (2013)	No	Present (observed in 2014)	Observed incidentally in the abandoned swimming pool. The pool does not meet the criteria as SWH.
<b>VASCULAR PLANTS</b>										
Butternut ( <i>Juglans cinerea</i> )	END	END	END	1	S2?	The butternut is designated as endangered by COSSARO and is tracked by the NHIC as a species at risk. The tree is federally regulated by the Species at Risk Act (2002). Butternut belongs to the walnut family and produces edible nuts which are a preferred food source for wildlife. The range of butternut trees is south of the Canadian Shield on soils derived from calcium rich limestone bedrock. Butternut trees, which at one time were much more common to the south extending to the northern aspect of zone 6E, have been declining due to factors including forest loss and disease. Butternut trees suffer from a highly transmissible fungal disease called butternut canker. Butternut canker is causing very rapid decline in this tree species across its native range. The fungal disease is easily transmitted by wind and is very difficult to prevent. Trees often die within a few years of infection by butternut canker (Ministry of Natural Resource and Forestry, 2014).	NHIC (2025), MNR/Aurora District (2013)	No	Not observed during field studies.	None
<b>MAMMALS</b>										
Eastern Red Bat ( <i>Lasiurus borealis</i> )	-	END	END	-	S3	Eastern red bats roost in the foliage of deciduous or sometimes evergreen trees and occasionally in shrubs (Bat Conservation International, 2024; COSEWIC, 2024). Trees used as maternity roosts tend to be large diameter and tall, reaching or exceeding the height of the surrounding canopy. Their solitary roosting behaviour and well-camouflaged fur results in roosts being highly cryptic. Roost sites that have overhead foliage for cover and open flight space below are selected. Eastern red bats typically uses several trees during the breeding season (COSEWIC, 2024).	Professional Experience	Potential	Treed Areas in setbacks contain potential roost trees.	Bat habitat (roost trees) is to be preserved in the woodlands to be retained and buffered from development. Only one potential tree >25 cm DBH to be removed. Timing windows of April 1 to November 30 to be observed, for all bat species. A Rocket Box will be erected as an interim measure.

NAME	SARA STATUS	SARO	COSEWIC	SCHEDULE	S-RANK	HABITAT REQUIREMENTS	SOURCE OF RECORD	HABITAT PRESENT (Y/P/N)	RATIONALE	POTENTIAL IMPACTS AND MITIGATION
Hoary Bat ( <i>Lasiurus cinereus</i> )	-	END	END	-	S3	Hoary bats roost solitarily among the foliage of trees, with preferences including maple, oak, ash, elder, hemlock, and redwood trees (Bat Conservation International, 2024). Trees used as maternity roosts tend to be large diameter and tall, reaching or exceeding the height of the surrounding canopy. There is little information regarding roost switching and roost area for Hoary Bats (COSEWIC, 2024).	Professional Experience	Potential	Treed Areas in setbacks contain potential roost trees.	Bat habitat (roost trees) is to be preserved in the woodlands to be retained and buffered from development. Only one potential tree >25 cm DBH to be removed. Timing windows of April 1 to November 30 to be observed, for all bat species. A Rocket Box will be erected as an interim measure.
Silver-haired Bat ( <i>Lasionycteris noctivagans</i> )	-	END	END	-	S3	Silver-haired Bats occurs primarily under bark and in the cavities of trees, making them reliant on habitats where large, decaying trees are available. Silver-haired Bats roost in a variety of large diameter coniferous and deciduous trees. Frequent roost switching is common (COSEWIC, 2024).	Professional Experience	Potential	Treed Areas in setbacks contain potential roost trees.	Bat habitat (roost trees) is to be preserved in the woodlands to be retained and buffered from development. Only one potential tree >25 cm DBH to be removed. Timing windows of April 1 to November 30 to be observed, for all bat species. A Rocket Box will be erected as an interim measure.
Tri-colored Bat ( <i>Perimyotis subflavus</i> )	END	END	END	1	S3?	Tri-colored Bat is a small bat that is widely distributed in eastern North America and whose range extends north to southern Ontario. Tri-colored Bat is rare in this region of Ontario which is at the northernmost limit of the natural range for the species. These bats prefer to nest in foliage, tree cavities and woodpecker holes, and are occasionally found in buildings; though this is not their preferred habitat. Winter hibernation takes place in caves, mines and deep crevices. Tri-colored Bat feed primarily on small insects and prefer an open forest habitat type in proximity to water (University of Michigan Museum of Zoology, 2004).	Professional Experience	Potential	Treed Areas in setbacks contain potential roost trees.	Bat habitat (roost trees) is to be preserved in the woodlands to be retained and buffered from development. Only one potential tree >25 cm DBH to be removed. Timing windows of April 1 to November 30 to be observed, for all bat species. A Rocket Box will be erected as an interim measure.
Little Brown Myotis ( <i>Myotis lucifugus</i> )	END	END	END	1	S3	Little brown myotis, a bat, are an endangered species threatened by a disease known as white nose syndrome, caused by a fungus from Europe. Little brown myotis have glossy brown fur and usually weigh between four and 11 grams. Bats are nocturnal. During the day they roost in trees and buildings. They often select attics, abandoned buildings and barns for summer colonies where they can raise their young. Little brown myotis hibernate from October or November to March or April, most often in caves or abandoned mines that are humid and remain above freezing – an ideal environment for the fungus to grow and flourish. The syndrome affects bats by disrupting their hibernation cycle, so that they use up body fat supplies before the spring when they can once again find food sources (Ministry of Natural Resources and Forestry, 2014).	Professional Experience	Potential	Treed Areas in setbacks contain potential roost trees.	Bat habitat (roost trees) is to be preserved in the woodlands to be retained and buffered from development. Only one potential tree >25 cm DBH to be removed. Timing windows of April 1 to November 30 to be observed, for all bat species. A Rocket Box will be erected as an interim measure.
Northern Myotis ( <i>Myotis septentrionalis</i> )	END	END	END	1	S3	Northern myotis, a bat, are an endangered species threatened by a disease known as white nose syndrome, caused by a fungus from Europe. Northern myotis have dull yellow-brown fur with pale grey bellies. They are approximately eight cm long, with a wingspan of about 25 cm, and usually weigh six to nine grams. Northern myotis can be found in boreal forests but occurs throughout southern Ontario to the north shore of Lake Superior and occasionally as far north as Moosonee. roosting under loose bark and in the cavities of trees. Northern Myotis roosts within tree crevices, hollows and under the bark of live and dead trees, particularly when trees are located within a forest gap. These bats hibernate from October or November to March or April, most often in caves or abandoned mines (Ministry of Natural Resources and Forestry, 2014).	Professional Experience	Potential	Treed Areas in setbacks contain potential roost trees.	Bat habitat (roost trees) is to be preserved in the woodlands to be retained and buffered from development. Only one potential tree >25 cm DBH to be removed. Timing windows of April 1 to November 30 to be observed, for all bat species. A Rocket Box will be erected as an interim measure.

FISH

NAME	SARA STATUS	SARO	COSEWIC	SCHEDULE	S-RANK	HABITAT REQUIREMENTS	SOURCE OF RECORD	HABITAT PRESENT (Y/P/N)	RATIONALE	POTENTIAL IMPACTS AND MITIGATION
American Eel ( <i>Anguilla rostrata</i> )	-	END	THR	-	S1?	The American eel is a long, slender bodied fish, with one long fin extending down the back and around the tail, and two small pectoral fins. It has thick lips, and a protruding lower jaw that extends out above the upper jaw. American eel spawn in the Sargasso Sea and the larva drift up the eastern seaboard of North America before undergoing metamorphosis into glass eels and then elvars. At this stage the juveniles swim up the St. Lawrence River to reach Lake Ontario and connected tributaries where they will remain for eight (8) to 23 years before migrating back to their spawning grounds. In Ontario the American eel prefers mud, sand or gravel substrates during the juvenile stage when they reside primarily in the benthic zone of waterbodies. More mature eels are able to thrive in most environments provided there is available cover during daylight hours, and the habitat is accessible. The greatest threat to this species is the density and design of hydro power facilities along migration routes. American eels are affected during migration by the inability to pass these barriers while travelling upstream, and the high rates of mortality experienced by individuals pulled into turbines while heading downstream (Government of Canada, 2016).	NHIC (2025). MNRF Aurora District (2013)	Potential	Likely to migrate through the Credit River during their life cycle (Dougan, 2017).	Potential for sedimentation into Credit River. Proper ESC measures to protect the Credit River during construction. Naturalization of bluffs to buffer and setback the river post-construction.
Lake Sturgeon (Great Lakes - Upper St. Lawrence River population) ( <i>Acipenser fulvescens</i> )	No Status	END	THR	No Schedule	S3	The lake sturgeon is a large freshwater fish, has an extended snout with four whisker-like organs hanging near the mouth and is dark to light brown or grey on its back and sides with a lighter belly. Lake sturgeon's live almost exclusively in freshwater lakes and rivers with soft bottoms of mud, sand or gravel and are usually found at depths of five (5) to 20 metres. Improvements in water quality and the strict regulation or elimination of commercial and recreational fishing of lake sturgeon in Ontario have positively impacted populations, while habitat fragmentation and regulated water flows from dams are the greatest threats to this species (Ministry of Natural Resources and Forestry, 2014).	NHIC (2025)	Potential	Potential to migrate through the Credit River during their life cycle .	Potential for sedimentation into Credit River. Proper ESC measures to protect the Credit River during construction. Naturalization of bluffs to buffer and setback the river post-construction.

Notes:

- SC - Special Concern
- THR - Threatened
- END - Endangered
- S1 - Extremely rare in Ontario
- S2 - Very rare in Ontario
- S3 - Rare to uncommon in Ontario
- S4 - Considered to be common in Ontario
- S5 - Species is widespread in Ontario
- SH - Possibly extirpated
- S#S# - Indicates insufficient information exists to assign a single rank.
- S#? - Indicates some uncertainty with the classification due to insufficient data.
- S#N - Nonbreeding
- S#B - Breeding
- Y= Yes, P = Potential, N = No



# **Appendix E    Significant Wildlife Habitat Screening**

## **Updated Environmental Impact Study**

2935 & 2955 Mississauga Road, City of Mississauga

**590816 Ontario Inc.**

SLR Project No.: 209.065271.00001

April 28, 2026

SWH Type	Associated Species	Associated ELC Ecosites	Habitat Criteria	Presence (Y/P/N)	Rationale
<b>Seasonal Concentration Areas of Animals</b>					
Waterfowl Stopover and Staging Areas (Terrestrial)	Duck-like species, Tundra Swan	CUM + CUT ecosites	Fields with sheet-water flooding mid-March to May. Specific areas for Tundra Swan	N	Anthropogenic area without sheet flooding.
Waterfowl Stopover and Staging Area (Aquatic)	Ducks, Geese	Ponds, Lakes, Inlets, Marshes, bays, coastal inlets, watercourse used in migration, Swamps, Shallow Water Ecosites	Sewage & SWM ponds <b>not</b> SWH. Reservoir managed as a large wetland or pond/lake qualifies. Abundant food supply (inverts, shallow water veg)	N	Credit River may be a migratory route but the portion of the watercourse adjacent to the Project Site does not provide stopover or staging area.
Shorebird Migratory Stopover Area	Shorebirds	Beaches, Dunes, Meadow Marshes	Shorelines. Great Lakes Shores, including rocky ones. Sewage treatment ponds and storm water ponds <b>not</b> SWH.	N	Suitable vegetation community is absent.
Raptor Wintering Area	Eagles, Hawks, Owls	<b>Hawks/Owls:</b> Combination of both Forest and Cultural Ecosites <b>Bald Eagle:</b> Forest or swamp near open water (hunting ground)	<b>Raptors:</b> >20 ha, with a combo of forest and upland. Meadow (>15ha) with adjacent woodlands. <b>Eagles:</b> open water, large trees & snags for roosting.	N	Extensive urban woodland present but meadow communities are believed to be insufficient (<20 ha). One hawk nest was noted on site but habitat is not believed to be significant.
Bat Hibernacula	Big Brown Bat, Tri-coloured Bat	Caves, Crevices, mines, karsts	Buildings and active mine sites <b>not</b> SWH.	N	Suitable habitat is absent
Bat Maternity Colonies	Big Brown Bat, Silver-haired Bat	Deciduous or mixed forests and swamps.	Mature deciduous and mixed forests with >10/ha cavity trees >25 cm DBH.	N	Bat maternity roost surveys have not been conducted on site but given the limited area of trees cover and the linear nature of the remanant woodland the Project Site is not believed to support significant habitat.
Turtle Wintering Area	<b>Turtles</b> (Midland, N. Map, Snapping)	SW, MA, OA, SA, FEO, BOO (requires open waters)	<b>Free water beneath ice.</b> Soft mud substrate. Permanent water bodies, large wetlands, bogs, fens with adequate DO. Man-made is not SWH.	N	Suitable natural habitat is absent. The abandoned pool is a non-natural structure and is not believed to be a suitable wintering area.
Reptile Hibernaculum	Snakes	<b>Snakes:</b> Any ecosite (esp. w/ rocky areas), other than very wet ones. Talus, Rock Barren, Crevice, Cave, Alvar esp.	<b>Access below frost line:</b> burrows; <b>rock</b> crevices, piles or slopes, <b>stone</b> fences or foundations. Conifer/shrubby swamps/swales, poor fens, depressions in bedrock w/ accumulations of sphagnum moss or sedge hummock ground cover.	N	Suitable habitat is absent.
Colonially-nesting Bird Breeding Habitat (Bank and Cliff)	Cliff Swallow, N. Rough-winged Swallow	Habitat includes: banks, sandy hills/piles, pits, slopes, cliff faces, bridge abutments, silos, barns.	Exposed soil banks, does not a licensed/permitted aggregate area or new man-made features (2 yrs), nor bridges or buildings.	N	Both Bank Swallow and Northern-rough winged swallows were observed foraging in the area but there was no evidence of nesting on the bluff.
Colonially-nesting Bird Breeding Habitat (Tree/Shrubs)	Great Blue Heron, Black-crowned NightHeron, Great Egret, Green Heron	SWM2, SWM3, SWM5, SWM6, SWD1 to SWD7, FET1	Nests in live or dead standing trees in wetlands, lakes, islands and peninsulas. Shrubs and emergents may be used. Nests in trees are 11 - 15 m from ground, near tree tops.	N	Species absent during breeding bird surveys.
Colonially-nesting Bird Breeding Habitat (Ground)	Herring Gull, Great Black-backed Gull, Little Gull, Ring-billed Gull, Common Tern, Caspian Tern, Brewer's Blackbird	<b>Gulls/Terns:</b> Rocky island or peninsula in lake or river. <b>Brewer's Blackbird:</b> close to watercourses in open fields or pastures with scattered trees or shrubs.	<b>Gulls/Terns:</b> islands or peninsulas with open water or marshy areas. <b>Brewer's Blackbird colonies:</b> on the ground in low bushes close to streams and irrigation ditches.	N	Species absent during breeding bird surveys.
Migratory Butterfly Stopover Area	Painted Lady, Red Admiral, <b>Special Concern:</b> Monarch	Combination of open (CU) and forested (FO) ecosites (need one from each).	≥10 ha, located within 5 km of Lake Ontario or Lake Erie. Undisturbed sites, with preferred nectar species.	N	Within 5 km of Lake Ontario but site has been disturbed over time; site is <10 ha. Nectar species are generally absent.
Landbird Migratory Stopover Areas	All migratory songbirds. All migrant raptor species.	Forest (FO) and Swamp (SW) ecosites	Woodlots >5 ha within 5 km of L. Ontario & L. Erie (2-5 ha if rare in area). If multiple woodlands are along the shoreline, those <2 km from L. Ontario are more significant.	N	Within 5 km of Lake Ontario but site does not support a swamp vegetation community.
Deer Winter Congregation Areas	White-tailed Deer	Mixed or Conifer ecosites	Determined by MNRF - no studies	N	Not identified to be present by MNRF
<b>Rare Vegetation Communities</b>					
Cliffs and Talus Slopes		TAO, TAS, CLO, CLS, TAT, CLT e.g., Niagara Escarpment (contact NEC)	<b>Cliff:</b> near vertical bedrock >3m <b>Talus Slope:</b> coarse rock rubble at the base of a cliff	N	Vegetation community absent.

SWH Type	Associated Species	Associated ELC Ecosites	Habitat Criteria	Presence (Y/P/N)	Rationale
Sand Barren		SBO1, SBS1, SBT1	Sand Barrens >0.5 ha. Vegetation can vary from patchy and barren to tree covered, but <60%. <50% vegetation cover are exotic species.	N	Vegetation community absent.
Alvar	<i>Carex crowei</i> , <i>Panicum philadelphicum</i> , <i>Eleocharis compressa</i> , <i>Scutellaria parvula</i> , <i>Trichostema brachiatum</i>	ALO1, ALS1, ALT1, FOC1, FOC2, CUM2, CUS2, CUT2-1, CUW2	Alvar >0.5 ha. <b>Need 4 of the 5 Alvar Indicator spp.</b> <50% vegetation cover are exotic species.	N	Vegetation community absent.
Old Growth Forest	Trees >140 yrs; heavy mortality = gaps. Multi-layer canopy, lots of snags and downed logs	FOD, FOC, FOM, SWD, SWC, SWM	Woodland areas 0.5 ha. No evidence of logging.	N	Vegetation community absent.
Savannah	Prairie Grasses w/ trees	TPS1, TPS2, TPW1, TPW2, CUS2	No min. size. A Savannah is a <u>tallgrass prairie</u> habitat that has tree cover of 25 – 60%. <50% cover of exotic species.	N	Vegetation community absent.
Tallgrass Prairie	Prairies Grasses dominate	TPO1, TPO2	No min. size. An <u>open Tallgrass Prairie</u> habitat has < 25% tree cover. Less than 50% cover of exotic species.	N	Vegetation community absent.
Other Rare Vegetation Communities		Provincially Rare S1 - S3 veg. comm. are listed in Appendix M of SWHTG.	Rare Vegetation Communities may include beaches, fens, forest, marsh, barrens, dunes and swamps.	N	Rare vegetation community absent.
<b>Specialized Habitat for Wildlife</b>					
Waterfowl Nesting Area	Ducks	Upland habitats adjacent to: MAS1 to MAS3, SAS1, SAM1, SAF1, MAM1 to MAM6, SWT1, SWT2, SWD1 to SWD4 (>0.5 ha open water wetlands, alone or collectively).	Extends 120 m from a wetland or wetland complex. Upland areas should be at least 120 m wide. Wood Ducks and Hooded Mergansers use cavity trees (>40 cm dbh).	N	Vegetation community absent.
Bald Eagle & Osprey Nesting, Foraging and Perching Habitat	Osprey, Bald Eagle	FOD, FOM, FOC, SWD, SWM, SWC directly adjacent to riparian areas	Nesting areas are associated with waterbodies along forested shorelines, islands, or on structures over water. Not man-made structures.	N	Suitable vegetation community present but species not observed during breeding bird surveys.
Woodland Raptor Nesting Habitat	Barred Owl. <b>Hawks:</b> N. Goshawk, Cooper's, Sharp-shinned, Red-shouldered, Broad-winged.	Forests (FO), swamps (SW), and conifer plantations (CUP3)	>30 ha with > 4 ha interior habitat (200 m buffer)	N	Suitable interior habitat is absent.
Turtle Nesting Areas	Midland Painted Turtle <b>Special Concern:</b> Snapping Turtle, Northern Map Turtle	Exposed mineral soil (sand or gravel) areas adjacent (<100m) or within: MAS1 to MAS3, SAS1, SAM1, SAF1, BOO1, FEO1	Nest sites within open sunny areas with soil suitable for digging. Sand and gravel beaches.	N	Suitable habitat is absent.
Seeps and Springs	Wild Turkey, Ruffed Grouse, Spruce Grouse, White-tailed Deer, Salamander spp.	Seeps/Springs are areas where ground water comes to the surface.	Any forested area within the headwaters of a stream/river system. (2 or more seeps/springs confirms SWH type).	N	Not observed during field investigations.
Amphibian Breeding Habitat (Woodland)	Woodland Frogs and Salamanders, E. Newt	FOC, FOM, FOD, SWC, SWM, SWD	Open water wetlands, pond or woodland pool of >500 m <sup>2</sup> within or adjacent to wooded areas. Permanent ponds or holding water until mid-July preferred.	N	Suitable habitat is absent.
Amphibian Breeding Habitat (Wetlands)	Toads, Frogs, and Salamanders, E. Newt	SW, MA, FE, BO, OA and SA. Typically isolated (>120m) from woodland ecosites, however larger wetlands may be adjacent to woodlands.	Open water wetland ecosites >500m <sup>2</sup> isolated from woodland ecosites with high species diversity. Permanent water with abundant vegetation for bullfrogs.	N	Suitable habitat is absent.
Woodland Area-Sensitive Bird Breeding Habitat	Birds (area-sensitive species)	FOC, FOM, FOD, SWC, SWM, SWD	Large mature (>60 years) forest stands/woodlots >30 ha. Interior forest habitat >200m from forest edge.	N	Suitable interior habitat is absent.
<b>Habitat of Species of Conservation Concern</b>					
Marsh Bird Breeding Habitat	Wetland Birds	MAM1 to MAM6, SAS1, SAM1, SAF1, FEO1, BOO1 <b>Green Heron:</b> SW, MA and CUM1	Wetlands with shallow water and emergent vegetation. Gr. Heron @ edges of these types w/ woody cover.	N	Suitable habitat is absent.
Open Country Bird Breeding Habitat	Upland Sandpiper, Grasshopper Sparrow, Vesper Sparrow, N. Harrier, Savannah Sparrow, <b>Short-eared Owl (SC)</b>	CUM1, CUM2	Grassland/meadow >30 ha. Not being actively used for farming. Habitat established for 5 years or more.	N	Suitable habitat is absent.
Shrub/Early Successional Bird Breeding Habitat	<b>Brown Thrasher + Clay-coloured Sparrow (indicators);</b> Field Sparrow, Black-billed Cuckoo, E. Towhee, Willow Flycatcher, Yellow-breasted Chat, Golden-winged Warbler	CUT1, CUT2, CUS1, CUS2, CUW1, CUW2	Large field areas succeeding to shrub and thicket habitats > 10 ha. Areas not actively used for farming in the last 5 years.	N	Suitable habitat is absent.



SWH Type	Associated Species	Associated ELC Ecosites	Habitat Criteria	Presence (Y/P/N)	Rationale
Terrestrial Crayfish	Chimney or Digger Crayfish; Devil Crayfish or Meadow Crayfish	MAM1 to MAM6, MAS1 to MAS3, SWD, SWT, SWM. CUM1 sites with inclusions of the aforementioned.	Wet meadow and edges of shallow marshes (no minimum size) should be surveyed for terrestrial crayfish (typc. protected by wetland setbacks).	N	Suitable habitat is absent.
Special Concern and Rare Wildlife Species	Any species of concern or rare wildlife species	Any ELC code.	Presence of species of concern or rare wildlife species.	N	Snapping Turtle was observed at the abandoned pool which is not considered a natural feature.
<b>Animal Movement Corridors</b>					
Amphibians	Amphibians	all ecosites assoc. w/ water	Movement corridors between breeding habitat and summer habitat.	N	Species absent during breeding bird surveys.
<b>Exceptions for Ecoregion 7E</b>					
Bat Migratory Stopover: 7E-2	Hoary Bat, Eastern Red Bat, Silver-haired Bat	No Specific ELC	Long Point (42°35' N, 80°30'E to 42°33' N, 80°03'E) - Silver-haired. Additional stopover areas currently unknown.	N	Limited presence of woodland cover associated with the Project Site. Not in Ecodistrict 7E-2.



# Appendix F Bat Rocket Box Plans

## Updated Environmental Impact Study

2935 & 2955 Mississauga Road, City of Mississauga

**590816 Ontario Inc.**

SLR Project No.: 209.065271.00001

April 28, 2026

## Two-chamber Rocket Box

### Materials (makes one house)

2" diameter (2 3/8" outside diameter) steel pole, 20' long  
 Two 1" x 4" (3/4" x 3 1/2" finished) x 8' boards\*  
 Two 1" x 8" (3/4" x 7 1/4" finished) x 8' boards\*

\* Western red cedar  
 or poplar preferred

Two 1" x 10" (3/4" x 9 1/4" finished) x 6' boards\*  
 24" x 24" x 3/4" piece of AC exterior plywood  
 Box of 100 exterior-grade screws, 1 5/8"  
 Box of 100 exterior-grade screws, 1 1/4"  
 16 to 32 exterior-grade screws, 2"

20 to 30 roofing nails, 7/8"  
 One quart water-based primer, exterior grade  
 Two quarts flat, water-based stain or paint,  
 exterior grade  
 Asphalt shingles or dark galvanized metal  
 One tube paintable latex caulk  
 Two 1/4" x 4 1/2" carriage bolts, washers and nuts

### Recommended tools

Table saw or circular saw  
 Caulk gun  
 Hammer  
 Tape measure  
 Square  
 Jigsaw, keyhole saw or router  
 Sandpaper or sander  
 Rasp or wood file  
 Variable-speed reversing drill  
 1 1/2" hole saw or spade bit  
 3/8" and 1/4" drill bits  
 Screwdriver bit for drill

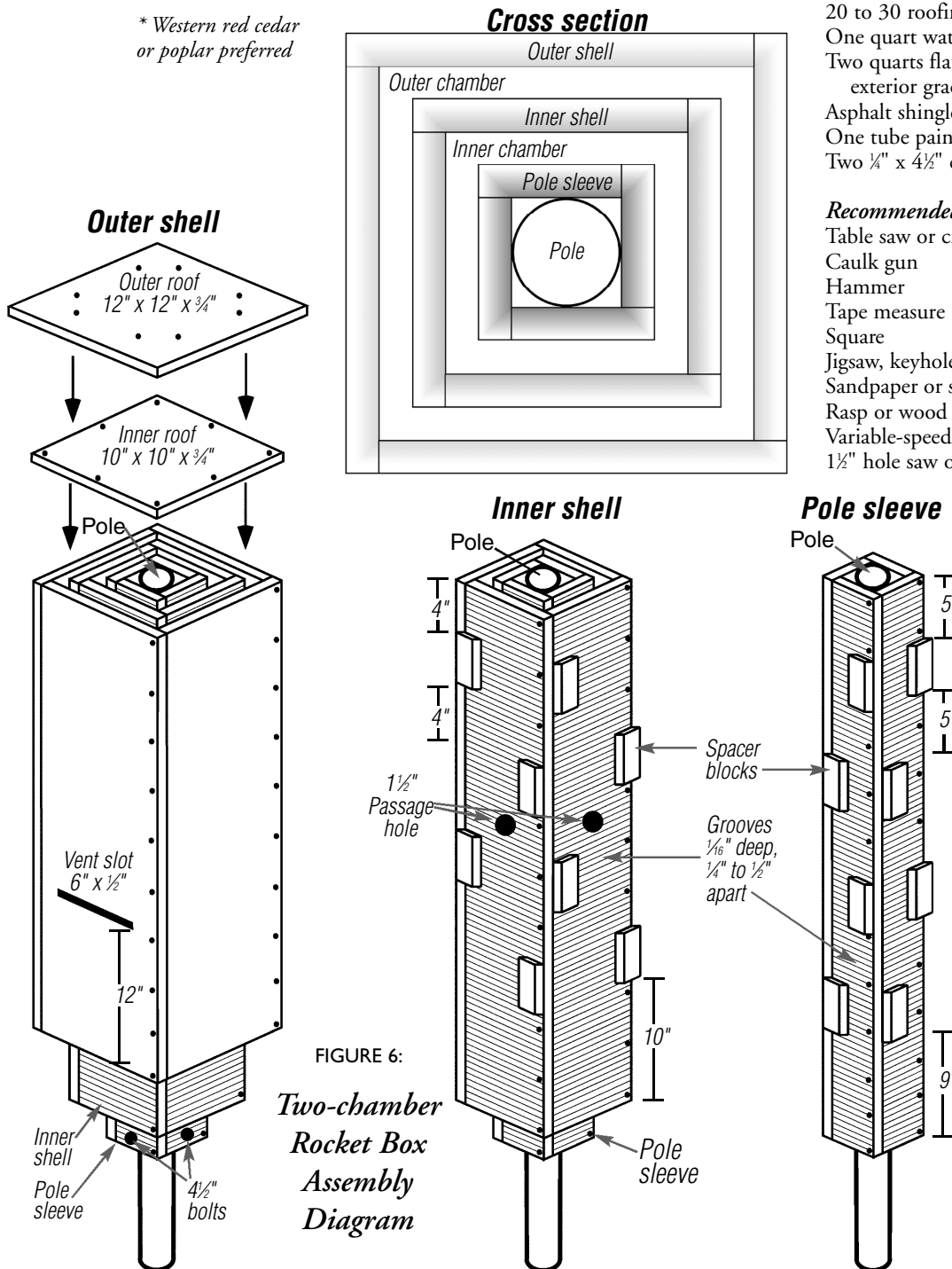

FIGURE 6:  
 Two-chamber  
 Rocket Box  
 Assembly  
 Diagram

### Construction

1. Measure, mark and cut out parts according to Figure 7. Dimensions must be exact for correct fit. Cut out two vent slots and four passage holes as shown.
2. Cut 1/6"-deep horizontal grooves 1/4" to 1/2" apart on one side of all 36" and 45" boards and on both sides of all 42" boards. Sand to remove splinters.
3. Drill two 3/8" holes through each 3/4" x 1 1/2" x 4" spacer block to prevent splitting.
4. Assemble four pole sleeve boards into a hollow, square box as shown using 1 1/8" screws and caulk. Pre-drill holes to prevent splitting. Countersinking holes may also help.

- Attach spacer blocks to pole sleeve as shown (four per side) using two 1/4" screws per block. Bottom spacer blocks are 9" up from bottom of pole sleeve. Top spacer blocks are 5" from top. Alternate spacer blocks on left and right sides, 5" apart.
- Assemble four inner shell boards into a hollow, square box as in step 4.
- Slide pole sleeve into inner shell until top edges are flush. Bat passage holes will be towards the top. Mark location of spacer blocks. Secure inner shell to pole sleeve with 2" screws through the spacer blocks to ensure no screws protrude into roosting chambers. Pre-drill holes first to avoid splitting spacer blocks (countersinking holes may also help).
- Attach spacer blocks (4 per side) to inner shell as shown, using two 1/4" screws per block. Bottom spacer blocks are 10" up from the bottom edge of the inner shell. Top spacers are 4" from top. Alternate spacers left and right sides, 4" apart.
- Assemble four outer-shell boards into a hollow, square box as in step 4. Vent slots are on opposing sides and oriented towards the bottom.
- Slide finished outer shell over inner shell, so that 6" of inner shell protrudes below outer shell. Mark locations of spacer blocks. Secure outer shell to inner shell as in step 7 (pre-drill holes first). Ensure that no screws protrude into the roosting chambers.
- Caulking first, attach inner roof to box with 1/4" screws. Carefully drive screws into top edges of shells to prevent screws from entering roosting chambers.
- Center and attach outer roof to inner roof with 1/4" screws, caulking first.
- Paint or stain exterior three times (use primer for first coat). Cover roof with shingles or dark galvanized metal.
- Slide completed rocket box over pole. One inch up from the bottom edge of pole sleeve, drill a 1/4" hole all the way through pole and sleeve. Rotate box and pole 90° and drill another 1/4" hole, 2 inches from the bottom, through pole and sleeve. Secure box to pole with two 4 1/2" bolts, washers and nuts. Orient vent slots north and south during installation.

**Optional modifications to the rocket box**

- For extra mounting height, insert a 4 1/2" bolt and nut about halfway up through pole sleeve after completing step 5.
- For extra heat-holding capacity, create a compartment in upper half of pole sleeve with a 2 1/2"-square piece of leftover plywood. Fill upper half of sleeve with sand, gravel or dirt, and seal with another piece of plywood flush with top.
- In warmer climates, a larger outer roof with more overhang can be used for additional shading.

**2' x 2' x 3/4" AC plywood**

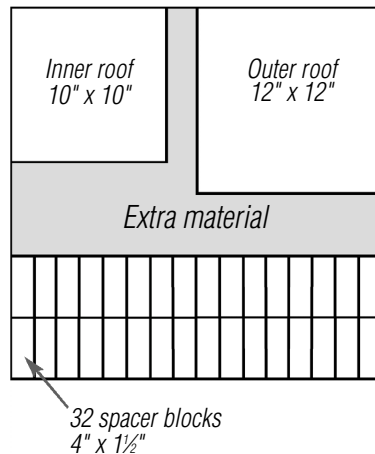
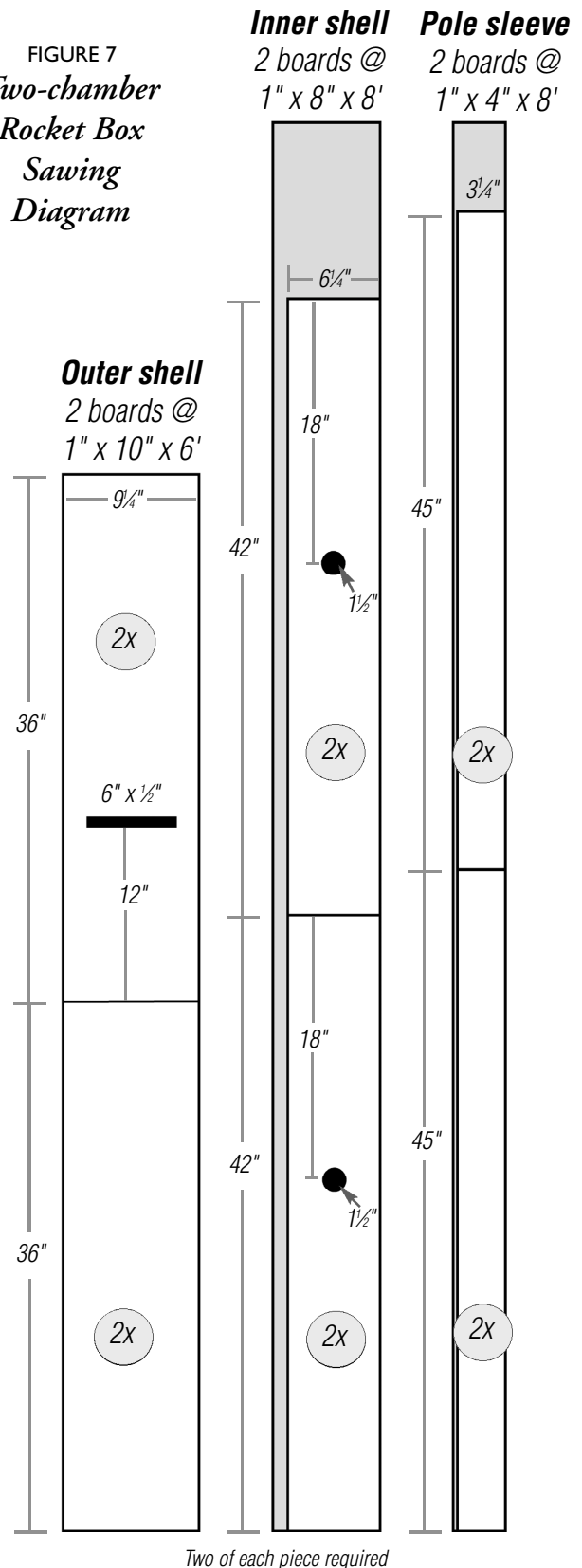

FIGURE 7  
**Two-chamber Rocket Box Sawing Diagram**





Making Sustainability Happen