



STREET LIGHTING DESIGN MANUAL



MISSISSAUGA

CITY OF MISSISSAUGA STREET LIGHTING DESIGN MANUAL

Version Control

Version 2 (December 2025)

Table of Contents

- 1 Introduction 1
- 2 General Requirements..... 3
- 3 Street Lighting Elements 4
- 4 Lighting Design Concepts 5
 - 4.1 Illuminance 5
 - 4.2 Luminance..... 5
 - 4.3 Uniformity 5
 - 4.4 Veiling Luminance 5
 - 4.5 Surround Ratio..... 6
 - 4.6 Contrast..... 6
- 5 Street Lighting Design Criteria and Considerations..... 8
 - 5.1 Luminaire Requirements 8
 - 5.2 Defining Required Lighting Levels - Street Classification and Pedestrian Activity 9
 - 5.2.1 Defining IES-RP-8 Street Classification 10
 - 5.2.2 Determining Pedestrian Activity Levels..... 10
 - 5.3 Lighting Level Requirements for Streets..... 12
 - 5.4 Sidewalks and Multi-use Trails..... 14
 - 5.5 Intersections..... 14
 - 5.6 Mid-block Crosswalks..... 17

| | | |
|-----|--|----|
| 5.7 | Roundabouts..... | 17 |
| 5.8 | School Zones..... | 18 |
| 5.9 | Street Trees..... | 19 |
| 6 | Design Calculations..... | 22 |
| 7 | Lighting Controls | 23 |
| | Appendix 1: Standard Drawings for Street Lighting Equipment..... | 25 |
| | Appendix 2: Street Lighting Approved Product List | 26 |
| | Appendix 3: City of Mississauga Street Classification System | 27 |

Tables

| | |
|---|----|
| Table 1: Defining IES-RP-8 Street Classification..... | 10 |
| Table 2: Pedestrian Activity Level Assignment | 11 |
| Table 3 Luminance Requirements for Streets..... | 13 |
| Table 4: Sidewalk and Mult-use Trail Illuminance | 14 |
| Table 5: Pavement Illuminance Criteria for Full Intersection Lighting (taken from Table 12-1 of RP-8-22)..... | 15 |
| Table 6: Pedestrian Lighting Recommendations. Adapted from Street Lighting for Pedestrian Safety (FHWA SA-20-062) | 19 |

Figures

| | |
|--|----|
| Figure 1 Surround Ratio Example..... | 6 |
| Figure 2 Negative (left) and positive (right) contrast..... | 7 |
| Figure 3 Mississauga’s Street Classification System..... | 10 |
| Figure 4 Pedestrian in Positive Contrast | 15 |
| Figure 5 Intersection Turning Movements and Pedestrian Conflict Points | 16 |
| Figure 6 Free Right Turn Movement Example..... | 16 |
| Figure 7 Crosswalk Pole Placement | 17 |
| Figure 8 Roundabout Pole Placement | 18 |
| Figure 9 Example of Light Blockage via Trees..... | 19 |
| Figure 10 Tree and Lighting Layout Options..... | 21 |
| Figure 11 Tree Pruning | 21 |

Abbreviations

| | |
|------|--|
| ASTM | American Society for Testing and Materials |
| CCT | Correlated Color Temperature |
| CEC | Canadian Electrical Code |
| CSA | Canadian Standards Association |
| FHWA | United States Federal Highway Administration |
| IES | Illuminating Engineering Society |
| K | Kelvin |
| LED | Light Emitting Diode |
| MMCD | Master Municipal Construction Documents |
| MTO | Ministry of Transportation Ontario |
| MUT | Multi Use Trail |
| NEMA | National Electrical Manufacturers Association |
| PEO | Professional Engineers Ontario |
| PMP | City of Mississauga Pedestrian Master Plan |
| TAC | Transportation Association of Canada |
| TMP | City of Mississauga Transportation Master Plan |
| UPD | Unit Power Density (Watts/m ²) |
| WCB | Workers' Compensation Board |

1 Introduction

Street lighting generally refers to the lighting of streets and roadways including sidewalks, crosswalks, intersections, roundabouts, and Multi-Use Trails (MUTs).

The principal purpose of street lighting is to enhance visibility at night. For a pedestrian, this may mean better visibility of the surrounds and the sidewalk, while for the driver of motor vehicles and cyclists, it will mean increased time to stop or to safely maneuver around an obstacle. Lighting mitigates glare from oncoming vehicle headlamps, a benefit not often considered, and provides a level of comfort for those using streets.

The City of Mississauga Street Lighting Design Manual has been created to define the design requirements for the City's sidewalk, multi-use trails and roadway lighting systems within the public right-of-way of the City of Mississauga. The City's Street Lighting Policy requires the use of this Manual when determining lighting need and developing street lighting designs. In this document, roadway lighting designers will be referred to as the "designer."

This manual sets lighting levels based on all road user needs. Ensuring that street lighting is designed and operated not just for motorists, but cyclists, pedestrians, and other road users, supports the Vision and Goals of the City's Transportation Master Plan, the development of the City's pedestrian and cyclist networks, as described by their respective Master Plans, and the City's Complete Streets Guide.

The following shall be considered the objectives of street lighting design for the City of Mississauga:

- Provision of adequate and uniform lighting levels for sidewalks, multi-use trails, roadways and adjacent bikeways along the City's public rights-of-way.
- Lighting criteria, as described in this manual, shall be achieved wherever economically and physically possible.
- Street lighting systems shall be energy-efficient and cost-effective.

This document references and uses information from IES RP-8-22, the US Federal Highway Administration (FHWA) Lighting Handbook, and the Transportation Association of Canada (TAC) Guide for the Design of Roadway Lighting. Where conflicts arise between the IES, the FHWA, and the TAC documents and this document, this document shall take precedence. Those undertaking street lighting designs should be

knowledgeable of all parts of the IES RP-8 and the Lighting Handbook and shall use those documents for reference when undertaking designs. This manual is not intended to be a substitute for sound engineering knowledge and experience in street lighting design.

Street lighting designs shall be prepared under the direction of a professional engineer registered with Professional Engineers Ontario (PEO).

2 General Requirements

Per the City of Mississauga's Street Lighting Policy (Policy #10-01-04), sidewalks, multi-use trails, and roadways within the public right-of-way of the City of Mississauga shall be illuminated. Light intrusion onto private property and non-travelled portions of the right-of-way shall be minimized.

The general requirements for lighting in the City are defined in this Manual. Where in question the designer, shall consult with the City's Street Lighting Section to clarify requirements. These guidelines speak to requirements for many of these features based on published design documents.

Full intersection lighting levels shall be provided at all signalized intersections and partial lighting at non-signalized intersections.

Lighting of guide signs will not be required where retro-reflective sign sheeting material is ASTM Grade IV or better. Signs shall be illuminated via sign luminaires where lower-grade sheeting is used or where car headlights will not illuminate the sign sheet due to road curvature. Where sign lighting is required, it shall meet the requirements as defined in RP-8-22.

3 Street Lighting Elements

The main element of a street lighting system is the luminaire which emits luminous flux (lumens) in the form of light. Other elements include poles, concrete bases, controls, conduit, wiring and an electrical service. The City has defined road cross sections for various road types and typical poles and luminaire types and also uses standardized equipment which includes typical poles and luminaire types as well as design standards.

Appendix 1 includes Standard Drawings for street lighting equipment. The designer shall be fully aware of and apply these standardized products and methods to their designs. More information on City Standard Drawings can be found on the City's website at:

<https://www.mississauga.ca/publication/transportation-and-works-standard-drawings/>.

The City uses LED luminaires for all new or replacement lighting installations. The designer shall refer to the City's Approved Product List (found in Appendix 2) for products pre-approved in the city.

In the case of a decorative application, the luminaire colour shall match the pole so the exact RAL (Reichs-Ausschuss für Lieferbedingungen) colour # shall be defined on the contract drawings.

Though the City has an approved product list, it is up to the designer to define the luminaire make and model number including, wattage, operating current and photometric distribution, colour temperature, and voltage on the contract drawings. The luminaire selected shall match that what is used for the lighting calculations. The designer shall select and define the specific make and model number as defined in the City's standards.

4 Lighting Design Concepts

Lighting design concepts include:

1. Illuminance
2. Luminance
3. Uniformity
4. Veiling Luminance
5. Surround Ratio
6. Contrast

These concepts are defined as follows:

4.1 Illuminance

Light is incident upon a surface will create “illuminance” on that surface. Illuminance is a measure of the light landing on a defined area therefore, the more lumens on a given surface area, the greater the level of illuminance. The illuminance method of design is used for lighting sidewalks, walkways, crosswalks, intersections and roundabouts and sections of curved roads.

4.2 Luminance

Luminance is the concentration of light (intensity) reflected towards the eyes per unit area of surface. As road surfaces do not reflect light uniformly, reflectance varies depending on the angle of the incident light in both the vertical and horizontal planes and, on the angle that the driver views the pavement. For a luminance calculation the driver’s viewing angle is fixed at one degree below the horizontal and an observer distance of approximately 83 metres. The luminance design method shall be used for all straight sections of road.

4.3 Uniformity

Uniformity is the evenness of the light over a given area. Even (uniform) lighting throughout an area would have a uniformity ratio of 1:1. A high degree of uniformity of street lighting has generally been accepted as desirable. As lighting calculations consist of a series of grid points with calculated luminance or illuminance levels, uniformity is expressed as the ratio of the average-to-minimum levels and/or the maximum-to-minimum levels. Uniformity ratios shall be used for all lighting scenarios.

4.4 Veiling Luminance

Veiling luminance (also referred to as disability glare) may be numerically evaluated. Because of contrast reduction by disability glare, visibility is

decreased. Increasing the luminance level will counteract this effect by reducing the eye's contrast sensitivity. As glare limits our visibility, veiling luminance is an important consideration. The effect of veiling luminance on visibility reduction is dependent upon the average lighting level, or average luminance level, of the pavement. Veiling luminance is expressed as a ratio of the maximum to the average veiling luminance. Veiling luminance shall be applied where luminance is calculated.

4.5 Surround Ratio

Providing lighting outside of the limits of the travel lanes has been shown to have significant benefits in terms of object detection (reference NCHRP Report 940). Accordingly, it is necessary to define the surround ratio. The surround ratio is calculated as the ratio of the average horizontal illuminance on the outermost (curb) lane to that of a similar area off the roadway adjacent to the outermost (curb) lane. Surround ratio is calculated in illuminance. For example, if the average horizontal illuminance on the outermost lane is 10 lux, to obtain the required surround ratio of 0.8:1, the surround area off the roadway would require a maintained average horizontal illuminance of no less than 8 Lux. IES RP-8-22 Chapter 10 defines surround ratio along with specific applications where surround ratio may have low benefit and therefore should be reviewed prior to applying. Figure 1 below provides an example of a high surround ratio (left) and a low surround ratio (right).



Figure 1 Surround Ratio Example

4.6 Contrast

For luminance contrast, an object that is darker than its background will be seen as “negative” contrast, while an object that is sufficiently brighter than its background will be seen as “positive” contrast. In Figure 2, the subject on the left is seen in negative contrast (a darker object silhouetted against a brighter background), while in the image on the right, the subject is seen in positive contrast (brighter object against darker background).



Figure 2 Negative (left) and positive (right) contrast

While it is usually better to create a positive contrast, many factors influence the ability to do so including the colour of the clothing and the background luminance along with other factors such as weather conditions (fog, snow, rain) and a driver's vision. Many of these factors are beyond the control of the lighting designer, nevertheless they should be considered.

Colour also provides additive contrast benefits. Colour contrast can improve the visibility of objects and pedestrians. This effect depends upon the colour of the object or clothing and the colour rendering ability of the source used for roadway lighting. However, this effect is variable in the environment. Both the light source spectrum and the spectral reflectivity affect the detection of objects in the roadway, which makes colour contrast quite situational and variable. This document includes design recommendations aimed at improving contrast. For more information on contrast refer to the FHWA Lighting Handbook.

5 Street Lighting Design Criteria and Considerations

Designs shall meet the design criteria defined in this Chapter, taken from IES RP-8-22. Lighting above and beyond the levels defined in IES RP-8-22 has not been shown to have a diminishing benefit. Therefore, it is recommended that lighting not exceed the maintained lighting level specified for the roadway by more than 50%. The 50% is a maximum target to allow for variability in the designs and is not absolute.

5.1 Luminaire Requirements

Luminaires shall be the minimum wattage required to provide the desired lighting at the optimized pole spacing. This will involve selecting the most effective luminaire photometric files and then optimizing the spacing via computer lighting design software. The designer shall adjust pole spacing to suit intersections, driveways, and lot configurations or, where the lighting poles exist, select the luminaire wattage, distribution and driver current which meets light level requirements.

To meet intersection light levels, luminaires shall be installed on signal poles to minimize the number of poles at the intersection. The pole spacing at intersections shall, therefore, be governed by the signal pole locations which are proposed or where signal poles would likely be located. Additional street light poles will be required to meet recommended vertical illumination levels in crosswalks.

Where existing luminaires are being replaced with new luminaires, it is the City's position to have the street lighting conversions meet and just exceed minimum performance criteria.

Where the road is not changing and it is not possible to meet the recommended lighting criteria, it is the City's position to maintain the same levels as provided by the existing installation. The designer shall model the existing lighting installation using computer calculation software in order to determine the existing light levels. The designer shall then provide lighting calculations (AGI files) to the City documenting the process and results prior to finalization of the design package. The City will review all AGI calculations.

Lighting design requires the use of computer lighting design software (AGI32) and the photometric files from lighting suppliers in IES format. Typically, luminaire photometric files are based on a lamp which can vary from actual lamp used in the test, provided it is similar. This is referred to

as “relative” photometry. For LED lighting the photometric files should be “absolute” which means the photometric file shall be the exact luminaire tested.

The designer shall select photometric files for luminaires which light the roadway and surround and / or sidewalks and reduce spill light and glare impacts on private properties. This shall be done by analyzing luminaire optical systems using the BUG method defined in Illuminating Engineering Society TM-15 Classification System for Outdoor Luminaires and Addendum A: Backlight, Uplight, and Glare (BUG) Ratings. The maximum nominal BUG rating of luminaires shall be B2-U0 however lower BUG rating should be used where possible. The glare rating (G) is not used. Where meeting the backlight rating limits (the ability to achieve the required sidewalk/surround lighting levels), the sidewalk/surround light levels shall take precedence and a higher backlight rating can be used.

5.2 Defining Required Lighting Levels - Street Classification and Pedestrian Activity

Streets, sidewalks, multi-use trails within the public right-of-way, intersections, and roundabouts require different levels of lighting based on the street classification and level of pedestrian /cyclist activity (conflict). To aid the designer, IES RP-8 street classification and pedestrian activity level designations determine the required luminance or illuminance, uniformity and veiling luminance lighting requirements described in Sections 5.3 to 5.9. It is important to note that a high level of pedestrian/cyclist activity may require additional poles and luminaires to meet the required levels of lighting on sidewalks.

This manual instructs designers to determine IES RP-8 street classification and pedestrian activity levels by referencing the City’s Street Classification System, and reference sections 5.2.1 and 5.2.2, below, which describe how the designer will use this classification system to determine IES-RP-8 street class and pedestrian activity designations.

The City’s Street Classification System has 14 street classes and is organized by four functional classes (arterial, major collector, minor collector and local), three place categories (Strategic Growth Areas, Neighbourhoods, and Employment Areas), and a scenic routes designation (Figure 3). A schedule of this classification system is included as Appendix 3 to this Manual. The most current schedule can be found in the City’s Official Plan, and the Official Plan schedule should be referenced.

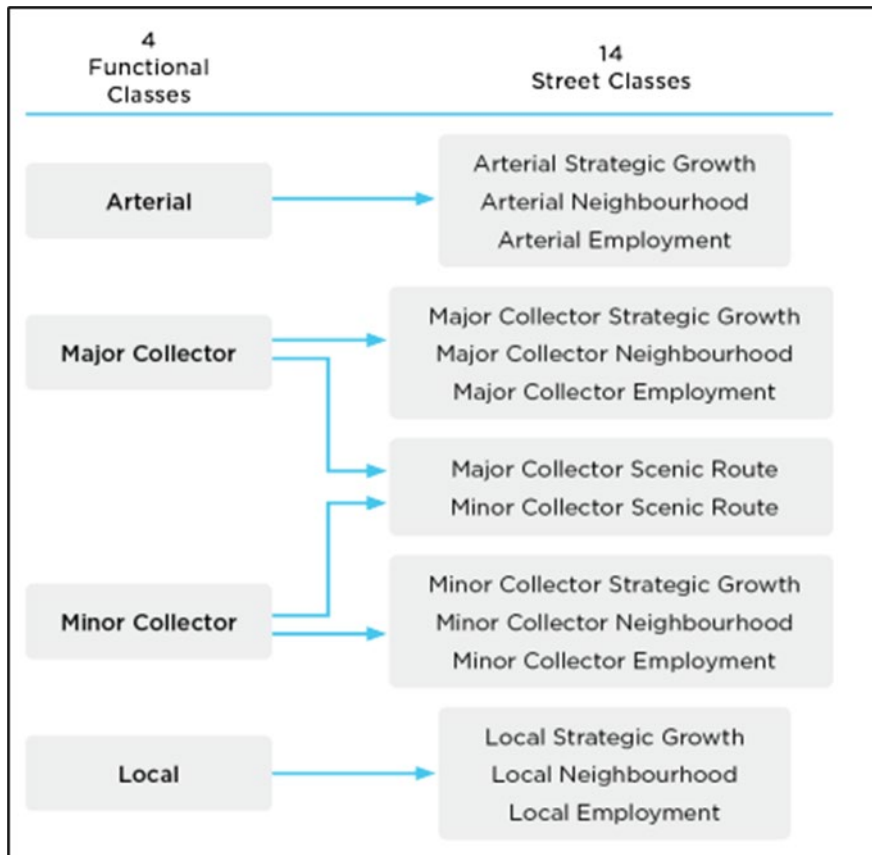

Figure 3 Mississauga's Street Classification System

5.2.1 Defining IES-RP-8 Street Classification

Designers are to determine the IES RP-8 Street Classification based on the correspondence to the City's functional classification system shown in Table 1.

| | | City of Mississauga Functional Classification | | | |
|-------------------------------------|-----------------|---|-----------------|-----------------|-------|
| | | Arterial | Major Collector | Minor Collector | Local |
| IES-RP-8 (22) Street Classification | Major Collector | X | X | | |
| | Local | | | X | |
| | | | | | X |

Table 1: Defining IES-RP-8 Street Classification

5.2.2 Determining Pedestrian Activity Levels

RP-8-22 recommends the following criteria to define pedestrian activity:

- **High** - Areas with significant numbers of pedestrians and cyclists expected to be on the sidewalks or crossing the streets during darkness. This will include streets in commercial areas with 100 pedestrians/cyclists or more in the one-hour period with the highest average annual nighttime pedestrian/cyclist volume. High level will typically be found in high vehicular traffic commercial areas and high-density residential with a population density of 3,000 or greater per square kilometre, transit stations and sports arenas.
- **Medium** - This shall apply to all roads with the exception of those defined as high or low.
- **Low** - Areas with low numbers of pedestrians/cyclists expected to be on the sidewalks or crossing the streets during darkness. This will include streets in industrial and residential areas with 10 pedestrians/cyclists or fewer in the one-hour period with the highest average annual nighttime pedestrian volume. The most common street with a low will be a local in single family home area or an industrial area or any other areas with low night-time activity. In cases where a larger volume of pedestrians/cyclists will be present for short duration then lighting levels should be adjusted to accommodate.

To aid the designer and to ensure that the City’s Complete Streets policies are achieved, the City will proactively define pedestrian activity based on the place categories of Mississauga’s Street Classification System. Pedestrian activity categories will be defined as follows:

| | | City of Mississauga Place Categories | | |
|---|--------|--------------------------------------|---|------------------|
| | | Strategic Growth Areas | Neighbourhoods | Employment Areas |
| IES-RP-8 22 Pedestrian Activity Categories | High | “High” for all classes | If IES-RP-8 street classification is “major”, default activity is “high”, unless designer demonstrates “medium” | |
| | Medium | <i>Not applicable</i> | | |
| | Low | <i>Not applicable</i> | If IES-RP-8 street classification is “minor” or “local”, default activity is “low”, unless designer demonstrates “medium” | |

Table 2: Pedestrian Activity Level Assignment

5.3 Lighting Level Requirements for Streets

Street lighting levels are defined in Table 3, and are based on the recommendations of IES RP-8-22.

When undertaking lighting calculations, lane width shall be measured from the road centre line to the face of curb unless a marked bike lane is present. Where bike lanes are encountered and are marked via pavement markings, then the travel lane measurement adjacent to the bike lane shall include the bike lane. Where bike lanes are separated from roadways via barriers or curbs, the lighting levels on the bike lane shall meet or exceed those for a MUT (listed below).

Where part-time parking lanes exist or are proposed, lighting shall be calculated as if they are full-time general-purpose lanes. Full time on-street angled or parallel parking, where there is no chance the parking lane will be used as a travel lane, shall also be included in the lighting calculations.

In areas where only one side of a road is to be developed, the lighting shall be designed for the complete road width, but only poles and luminaires along the property frontage being developed shall be installed. Locations and types of all future poles and luminaires shall be clearly indicated on the drawings and lighting calculation included.

Curved roadway sections (less than 600-meter radius) shall be calculated using the horizontal illuminance method using a 2m grid spacing on the travel lanes and bike lane only. For determining what horizontal illuminance level should be used as an equivalent to the recommended luminance level, a ratio of 1 cd/m² equal to 15 lux can be used for R2/R3, 10 Lux for R1 and 13.3 Lux for R3 road surfaces.

Field validation of a lighting systems performance may be done by illuminance. Field validation will only be required where specifically required by the City.

| Road Classification and Pedestrian Activity | | Maintained Average Pavement Luminance cd/m ² | Average-to-Minimum Uniformity Ratio | Maximum-to-Minimum Uniformity Ratio | Maximum-to-Average Veiling Luminance Ratio | Surround Ratio |
|--|---------------------|---|-------------------------------------|-------------------------------------|--|----------------|
| Road Classification | Pedestrian Activity | | | | | |
| Arterial (City Arterial and Major Collector) | High | ≥ 1.2 | ≤ 3.0 | ≤ 5.0 | ≤ 0.3 | 0.8:1≥ |
| | Medium | ≥ 0.9 | ≤ 3.0 | ≤ 5.0 | ≤ 0.3 | 0.8:1≥ |
| | Low | ≥ 0.6 | ≤ 3.5 | ≤ 6.0 | ≤ 0.3 | 0.8:1≥ |
| Collector (City Minor Collector) | High | ≥ 0.8 | ≤ 3.0 | ≤ 5.0 | ≤ 0.4 | 0.8:1≥ |
| | Medium | ≥ 0.6 | ≤ 3.5 | ≤ 6.0 | ≤ 0.4 | 0.8:1≥ |
| | Low | ≥ 0.4 | ≤ 4.0 | ≤ 8.0 | ≤ 0.4 | 0.8:1≥ |
| Local (City Local) | High | ≥ 0.6 | ≤ 6.0 | ≤ 10.0 | ≤ 0.4 | 0.8:1≥ |
| | Medium | ≥ 0.5 | ≤ 6.0 | ≤ 10.0 | ≤ 0.4 | 0.8:1≥ |
| | Low | ≥ 0.3 | ≤ 6.0 | ≤ 10.0 | ≤ 0.4 | 0.8:1≥ |

Table 3 Luminance Requirements for Streets

The following lighting parameters are to be used for roadway lighting design criteria:

- Average luminance L_{avg} (cd/m²).
- Average uniformity ratio (L_{avg}/L_{min}).
- Maximum-to-minimum uniformity ratio (L_{max}/L_{min}).
- Maximum-to-average veiling luminance ratio (L_{Vmax}/L_{avg}).
- Surround ratio.

5.4 Sidewalks and Multi-use Trails

The 2019 City Pedestrian Master Plan (PMP) defines a pedestrian network that is safe and comfortable for all. In line with the principles of Vision Zero, this will ensure that walking in Mississauga is safe and accessible for all residents and visitors regardless of age and ability. It includes providing accessible crossings, lighting and features that create safe and comfortable places to walk.

An action of the PMP is to “Review and develop a strategy to install additional lighting (where required) throughout the pedestrian network. Including pedestrian scale lighting along roadways and at intersections.”

To support the objectives of the PMP, all sidewalks shall be illuminated and meet the design criteria in . When calculating lighting for sidewalks which are un-colored concrete a 30% reflectance factor can be applied.

Multi-Use Trails (MUTs) within the public right-of-way of the City of Mississauga shall be illuminated and meet the design criteria shown in Table 4.

| Pedestrian Activity | Maintained Average Horizontal Illuminance (Lux) | Average-to-Minimum Horizontal Uniformity Ratio | Minimum Maintained Vertical Illuminance (Lux) - Desired but not Mandatory |
|---------------------|---|--|---|
| High | ≥10.0 | ≤5.0 | ≥5.0 |
| Medium | ≥5.0 | ≤5.0 | ≥2.0 |
| Low | ≥2.0 | ≤10.0 | ≥1.0 |

Table 4: Sidewalk and Multi-use Trail Illuminance

5.5 Intersections

Intersection lighting levels for various road classifications and pedestrian activity levels are defined in Table 5. This table is based on levels listed are based on the IES RP-8-22.

| IES RP-8-22 Road Classification | Pavement Illuminance Criteria for Full Intersection Lighting (Lux/ft) | | | Average-to-Minimum Uniformity Ratio |
|---------------------------------|---|--------|--------|-------------------------------------|
| | Pedestrian Activity Levels | | | |
| | High | Medium | Low | |
| Major/Major | 34/3.2 | 26/2.4 | 18/1.7 | 3.0 |
| Major / Collector | 29/2.7 | 22/2.0 | 15/1.4 | 3.0 |
| Major / Local | 26/2.4 | 20/1.9 | 13/1.2 | 3.0 |
| Collector / Collector | 24/2.2 | 18/1.7 | 12/1.1 | 4.0 |
| Collector / Local | 21/2.0 | 16/1.5 | 10/0.9 | 4.0 |
| Local / Local | 18/1.7 | 14/1.3 | 8/0.7 | 6.0 |

Table 5: Pavement Illuminance Criteria for Full Intersection Lighting (taken from Table 12-1 of RP-8-22)

Calculation grids shall be 2m as defined in IES RP-8-21. RP-8-22, Section 12.5, also notes vertical illuminance is crucial in crosswalks to improve pedestrian visibility. It recommends vertical levels should exceed horizontal lighting levels in the direction of approaching vehicles. In many cases, it is impractical to achieve desired vertical levels within the intersection crosswalks due to existing pole locations. The designer will determine if vertical levels can be attained with existing pole locations. If not, the designer will determine if additional poles or pole re-locations can attain the desired vertical levels.

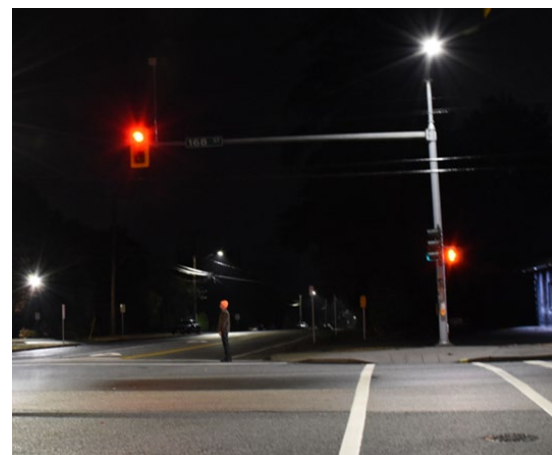

Figure 4 Pedestrian in Positive Contrast

Contrast is a significant factor specifically as it relates to detecting a pedestrian in the crosswalk, but is not a core criteria described in IES RP-8-22. In Figure 4, the pedestrian is clearly visible and seen in positive

contrast. This is the goal despite different approach configurations and viewing angles of the pedestrian for the driver.

With respect to intersections, it is important to look at points of conflict, specifically vehicle-to-pedestrian conflicts, and how contrast can be improved via lighting. To improve visibility in crosswalks, vertical illuminance is useful to improve contrast and better detect pedestrians. Vertical illuminance is calculated and measured in a vertical plain which would typically apply to a pedestrian whereas horizontal illuminance is calculated and measured on the road surface.

Figure 5 shows left- and right turns have a higher potential for vehicle-to-pedestrian conflicts and are of particular concern during hours of darkness. In the case of a permissive left turn, the driver is subject to the glare of approaching car head lamps while gaging gaps in traffic and avoiding pedestrians in the crosswalk. Improving contrast and enhanced lighting can benefit these drivers.

Providing 10 Lux vertical illuminance with calculation grid at around 1.5 m and facing the interior of the intersection in the areas shown in red in Figure 5 should improve contrast at these critical conflict areas. Achieving these conditions will require additional luminaires and/or the careful placement of the luminaires around the intersection.

Another area where vertical illuminance is recommended is in advance of a channelized right turn lane. In Figure 6 a pole is shown in advance of

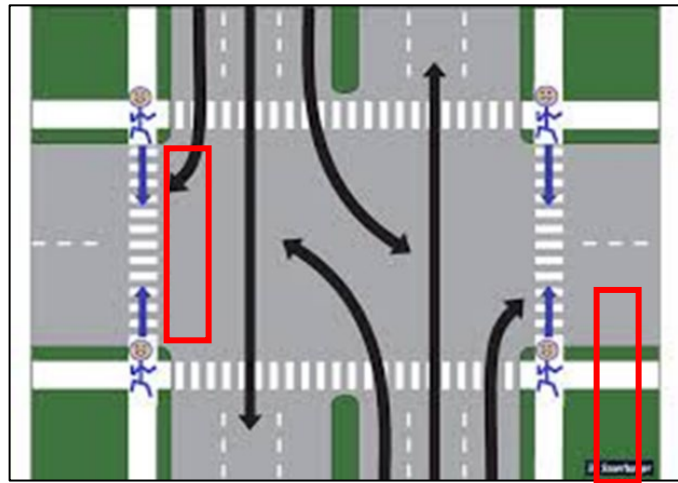

Figure 5 Intersection Turning Movements and Pedestrian Conflict Points

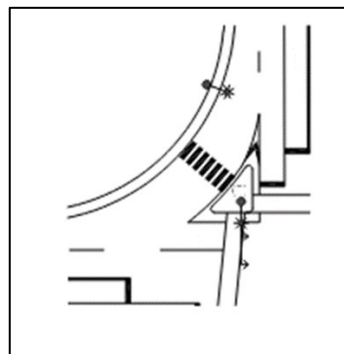

Figure 6 Free Right Turn Movement Example

the crosswalk at a distance equal to approximately $\frac{3}{4}$ of the mounting height of the luminaire to provide vertical illuminance at a similar level to a mid-block crosswalk. This lighting location will provide positive contrast and improve visibility of pedestrians in the crosswalk given car headlamps effectiveness maybe reduced given a vehicles approach angle to the crosswalks.

5.6 Mid-block Crosswalks

An average maintained vertical illuminance of not less than 20 Lux measured at 1.5 m above the road surface is required at crosswalks to improve contrast and visibility of a pedestrian. This can be achieved by placing poles in advance of the crosswalk to create high levels of vertical illumination thus improving the driver's visibility of the pedestrians (see Figure 7). For further information refer to IES RP-8-22.

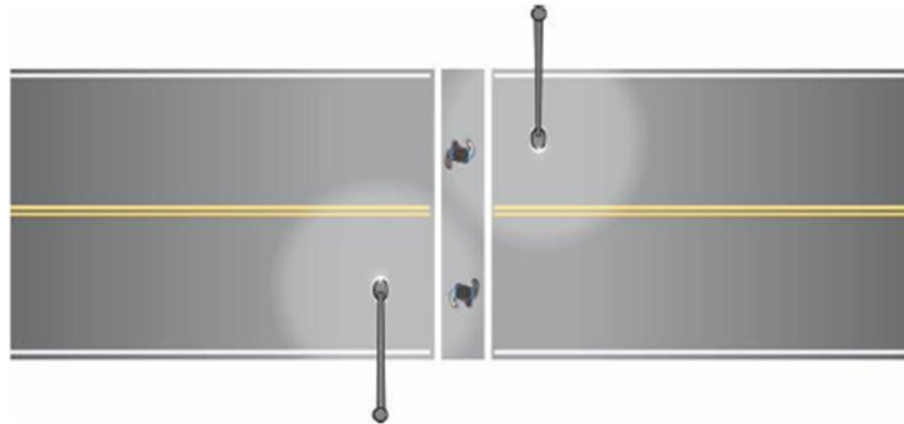

Figure 7 Crosswalk Pole Placement

5.7 Roundabouts

Roundabouts have more complex visibility considerations than typical intersections. The effectiveness of motor vehicle headlights is limited in a roundabout due to the constrained curve radius, making the street lighting system a necessity to aid in the nighttime visibility of obstructions, hazards, and pedestrians in crosswalks.

Lighting for a roundabout shall meet or exceed the horizontal illuminance levels defined for intersections. Where crosswalks are present lighting levels in crosswalks shall meet vertical lighting levels listed for midblock crosswalks. An example of lighting pole locations for roundabouts with crosswalks is defined in Figure 8.

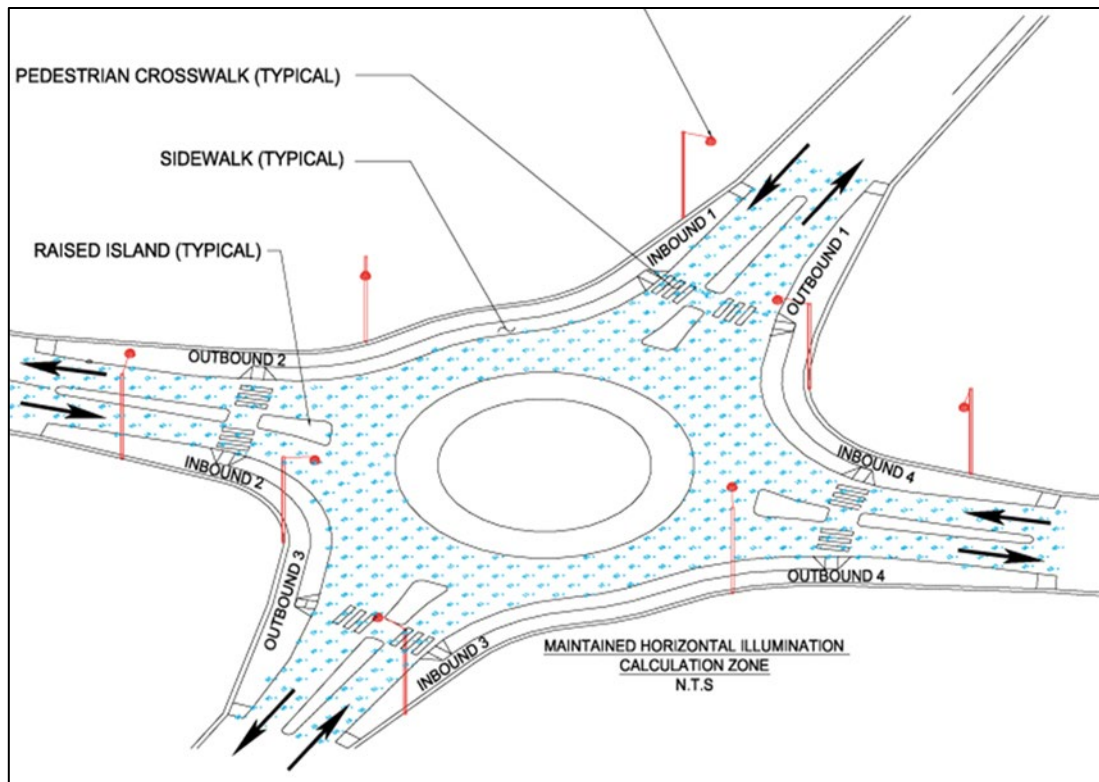

Figure 8 Roundabout Pole Placement

Where there is no lighting on the approach street lighting should be added on the approach roads for a distance of approximately 80 m from the roundabout crosswalks. For further information on Roundabout Lighting refer to IES RP-8-22.

5.8 School Zones

Lighting is important for the safe travel of school-age children in school zones. Children travel to school at twilight in both morning and afternoon, creating unique issues given they are especially vulnerable to traffic. In addition to being small and easily distracted, children have difficulty judging the direction of sounds, estimating the speed and distance of oncoming vehicles, and anticipating driver behaviour. Children have a limited ability to judge the available gap in traffic, meaning they have difficulty crossing a street safely. Younger children also take more time to take the first step in crossing the street, shortening the available gap.

Recent research provides recommendations for lighting areas used by children walking to school for sidewalks in both rural and urban areas. Careful consideration to the characteristics of urban and rural environments must be given to account for the contrast, visual clutter,

and multiple light sources that can impact a pedestrian’s visibility. The results of the research show increased lighting levels are required to accommodate children specifically in school zones as shown in Table 6. Semi-cylindrical illuminance was used while conducting the research and can be calculated using AGI32 lighting calculation software however the less common semi-cylindrical calculation can be substituted for a vertical illuminance calculation.

| | Illuminance | Luminance | |
|--|-----------------|---------------|---------------------|
| | Minimum | Rural Average | Urban Average |
| Low / Medium Pedestrian Activity | 3 lux vertical | | 1 cd/m ² |
| High Pedestrian Activity or School Zones | 10 lux semi-cyl | 2 cd/2 | 2 cd/m ² |

Table 6: Pedestrian Lighting Recommendations. Adapted from Street Lighting for Pedestrian Safety (FHWA SA-20-062)

5.9 Street Trees

Trees pose a challenge to the lighting design as they block light and, thus, reduce lighting below required levels, an example of which is shown in Figure 9. Nevertheless, the City’s Complete Streets Guide reiterates that large, healthy street trees provide substantial benefit, including contributing to pedestrian and cyclist comfort.



Figure 9 Example of Light Blockage via Trees

For street lighting design, the designer must recognize and consider the impact of existing or proposed streets trees onto lighting. Where trees are proposed lights may have to be installed on custom arms which extend out over the roadway beyond the ultimate tree canopy. With the lighting extended over the roadway additional pedestrian scale lighting will often be required to properly light the sidewalks. The proposed

locations, spacing, pole height, arm length and frequency of the trees may also need to be adjusted in conjunction with the lighting pole spacing. A tighter pole spacing than calculated may be required to compensate for anticipated light blockage resulting in additional poles and luminaires.

Some examples of lighting layouts and trees are defined in Figure 10. These layouts show some options for locating lighting poles and trees. The height and size of tree canopy (drip line), light level requirement and pole heights are factors when defining the lighting layout. Typically using only pedestrian scale lighting will not be suitable for roads with trees which are over two lanes wide. The key is to take the impacts of the tree trunk and canopy (at fully maturity) into account in the lighting design. This may mean using pedestrian scale to light under the tree canopy to reduce light blockage.

For new installations with trees the tree type and layout will typically be designed by a landscape architect. It is imperative the lighting be designed and integrated into the design of the trees. In fact, the tree spacing will often have to be adjusted. The lighting cannot simply be designed in isolation from the landscape design as the landscape design will impact the lighting levels.

Where trees exist and where they will impact lighting, tree pruning can be considered. Figure 10 shows the recommended procedure of assessing and mitigating the impacts of trees via pruning. Where pruning is required, its viability shall be discussed with the City and their Arborist. As trees vary in foliage, shape, and size it is not practical to calculate the exact impacts.

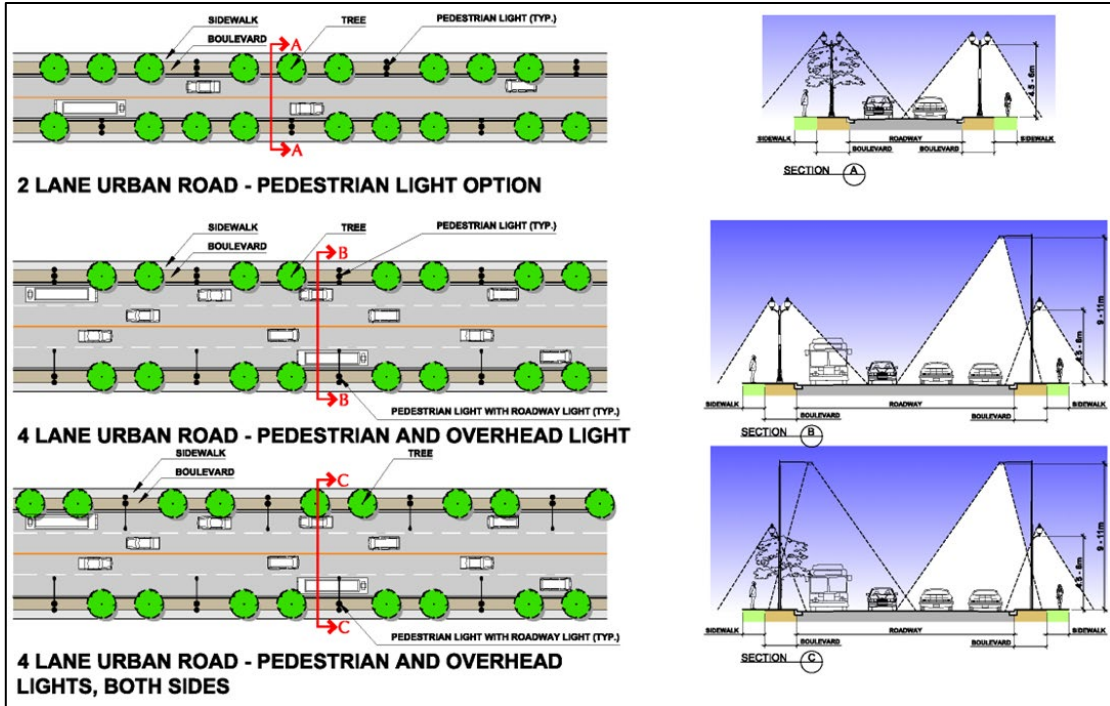

Figure 10 Tree and Lighting Layout Options

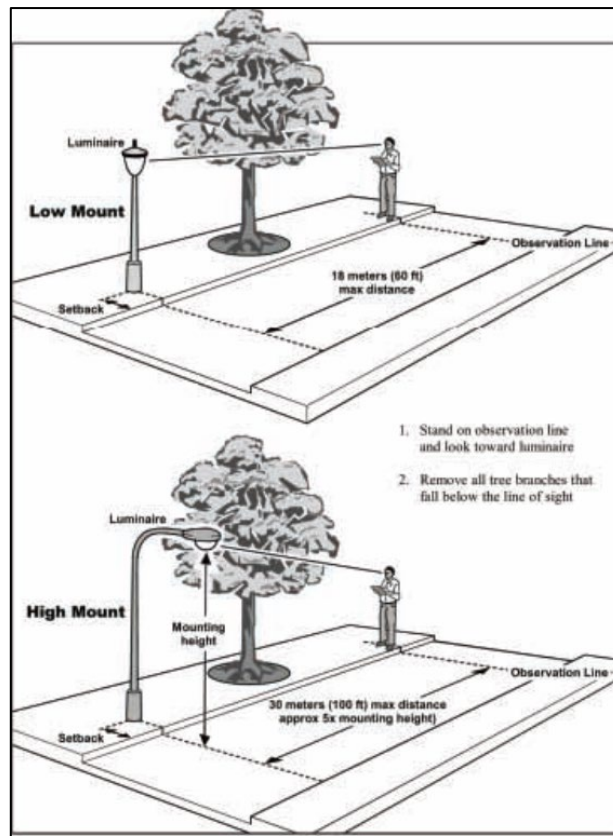

Figure 11 Tree Pruning

6 Design Calculations

The designer shall provide lighting calculations using AGI32 calculation software. Calculations shall show lanes and geometrics, lighting requirements and levels achieved for the worst-case pole spacing for each road type. Calculations shall be provided for roadways, sidewalks, roundabouts, MUTs and intersections. This shall include horizontal calculations as well as vertical calculations where crosswalks are present.

7 Lighting Controls

The City uses a lighting control system which will vary light levels and monitor the status of the streetlights. The application as it relates to lighting design is as follows:

Reduce Initial Light Output to Maintained Levels - Light output from luminaire depreciates over time. To maintain the minimum required lighting levels on the roads and sidewalks, lighting designs shall be based on initial levels and dimmed by factor to accommodate light depreciation over the life of the luminaire. This factor is typically around 20% to 25% depending on the luminaire. Applying adaptive technology controls the light output over time so the luminaires will operate at a maintained level for the entire maintenance cycle, thus reducing power input and saving energy. In the case of the City 25% shall be applied to the lighting design. It shall consist of 20% for Luminaire Dirt Depreciation and 5% for Lamp Lumen Depreciation based on a 20 year -luminaire life. It is recommended the lighting control system be set up to increase lumen output by approximately 1.25% per year. In case where are day burners the control system should be set to adjust the lumen depreciation factor.

Dimming Areas Over Lighted to Meet Uniformity - Some roads are over-lit to meet uniformity criteria, which is often the main factor in defining the luminaire pole spacing. In many cases, there is a lack of luminaires available in the appropriate wattage. As an example, the design requires a 65W luminaire which is not available, and the next wattage is 90W, resulting in over lighting. In this case the control system can simply reduce the lumen output via the controls to 65W.

Match Light Output to Pedestrian /Cyclist Activity Levels - The amount of light required for a roadway or sidewalk is based on two significant criteria: the classification of the roadway itself and the level of pedestrian activity. The classification of the roadway is based on the number of lanes and the volume of traffic and is defined by City. The pedestrian activity level is established by the lighting designer by estimating the number of pedestrians on the sidewalk in a single block (or 200 m segment) for a given one-hour nighttime sample period (typically between the 18:00 and 19:00 hours). The sample period is typically the hour of highest nighttime pedestrian conflict. Pedestrian activity levels do not remain constant throughout the hours of darkness, and in most instances the numbers of pedestrians present in a given area will be dramatically reduced in the late night and early morning hours. The City will allow dimming from high to medium and medium to low during off peak period from 11:00PM to

dawn. This shall be programmed into the lighting controls. Another example is in school zones where higher light levels are required during school hours during hours of darkness. As the hours of darkness change by time of year an adaptive system can be set to provide the higher light levels only when school is in operation during hours of darkness.

Reducing lighting levels based on pedestrian activity levels is not recommended in all lighting scenarios. Listed below are scenarios where reducing lighting levels in off-peak periods is not recommended:

- Signalized Intersections - Signalized intersections typically include pedestrian crossings. Pedestrian conflicts with vehicles are very likely at signalized intersections, even during low pedestrian conflict periods. Intersections also pose increased risk to pedestrians and as such should not be reduced.
- Mid-Block Crosswalks - The decision not to dim mid-block crosswalks follows the same logic as stated for signalized intersections.
- Roundabouts - Due to the complex geometry in roundabouts and the ineffectiveness of fixed headlights within the tight roundabout circle, it was determined that dimming should not be applied to these facilities. Roundabouts are an alternative to signalized intersections and may also contain pedestrian crossings which should not be reduced.
- Rail Crossings - Rail crossing lighting is provided for detection of the trains and not related to pedestrian conflict levels. Therefore, reducing lighting levels during off-peak periods is not recommended.
- Commercial Areas with high late night pedestrian traffic such as bars and sporting arenas.

The application of adaptive technology will require review and assessment on a per road or per area basis.

Appendix 1: Standard Drawings for Street Lighting Equipment

Appendix 2: Street Lighting Approved Product List

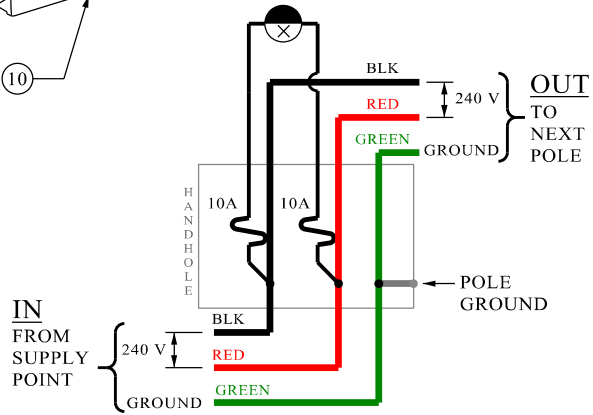
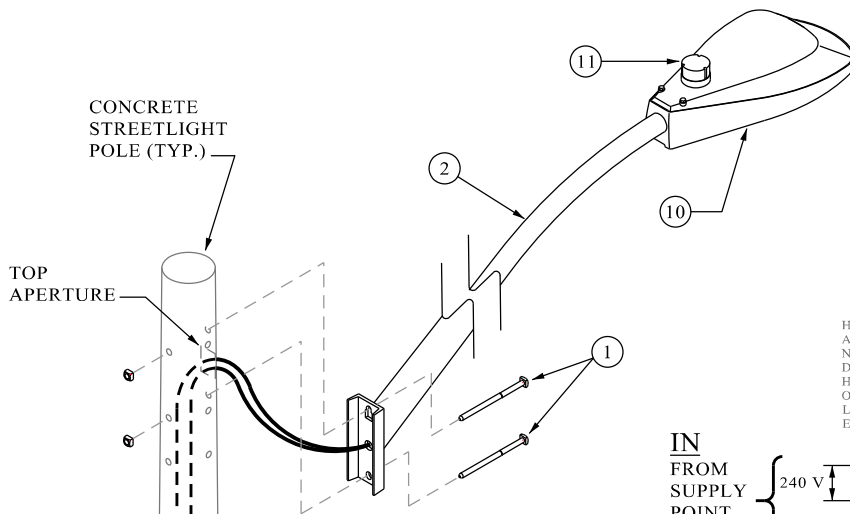

SCHMATIC DIAGRAM

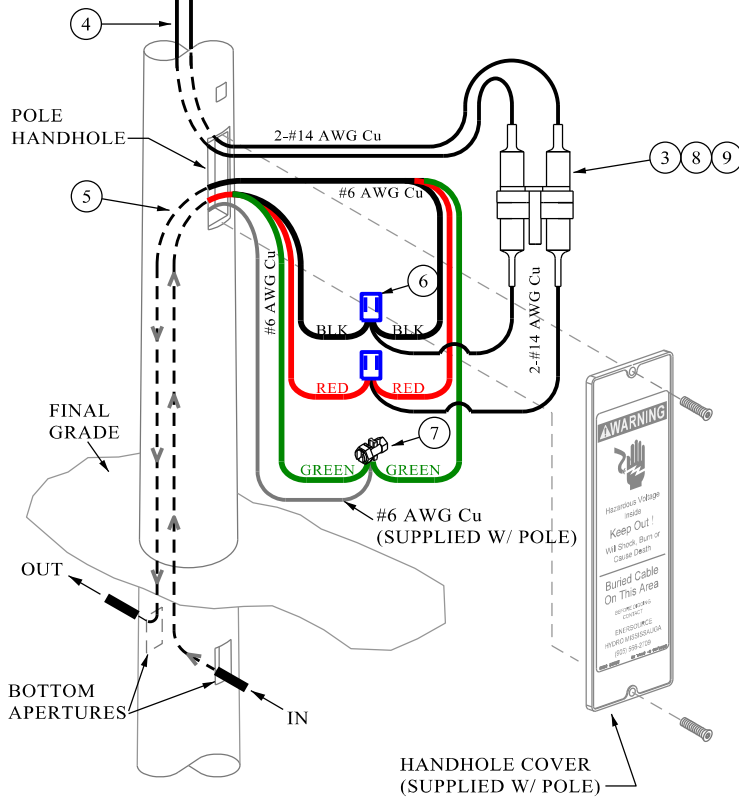

| BILL OF MATERIALS | | |
|-------------------|--|-----|
| ITEM# | DESCRIPTION | QTY |
| 1 | BOLT, MACHINE, 5/8" x 10" | 2 |
| 2 | BRACKET, LUMINAIRE, 8' | 1 |
| 3 | BOOT, INSULATING | 4 |
| 4 | CABLE, 2-#14 Cu SOLID, PVCJ, 600 V | ++ |
| 5 | CABLE, 3-#6 Cu STR, RWU90, XLPE, 1000 V | ++ |
| 6 | CONNECTOR, BOLTED, 3-HOLE #14-#2/0 & #14-#6 C/W GEL CAP | ++ |
| 7 | CONNECTOR, SPLIT BOLT | 1 |
| 8 | FUSE, CARTRIDGE, 10A | 2 |
| 9 | FUSE HOLDER, IN-LINE, DOUBLE POLE, 30A, 600V | 1 |
| 10 | City Approved LED Luminaire (as supplied by CoM approved luminaire supplier) | 1 |
| 11 | Adaptive Control Node (as supplied by CoM approved Node Supplier) | 1 |

++ - LENGTH/QUANTITY TO SUIT



**STREETLIGHTING - 240 V
U/G SYSTEM DESIGN - NO NEUTRAL**

INDIVIDUALLY CONTROLLED AND FUSED

| | | | | |
|-----------|-----|------------|-----------------------|--------|
| EFF. DATE | | | SCALE | N.T.S. |
| REV. | 001 | 2025 09 12 | STANDARD No. 3100.020 | |

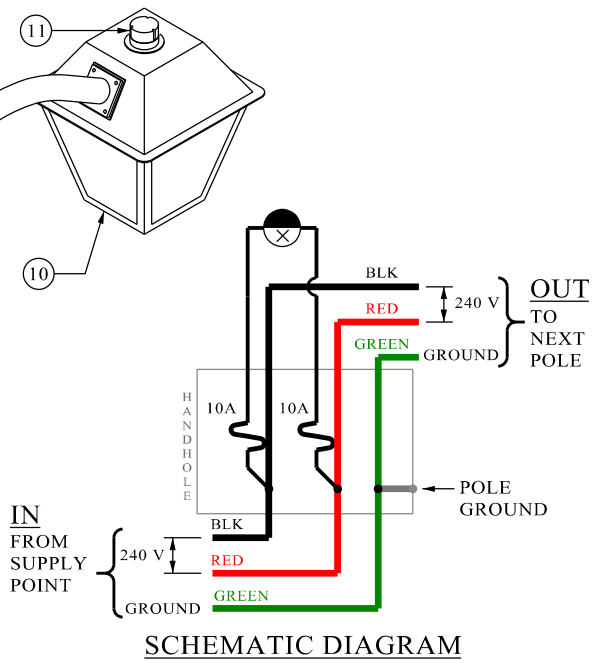
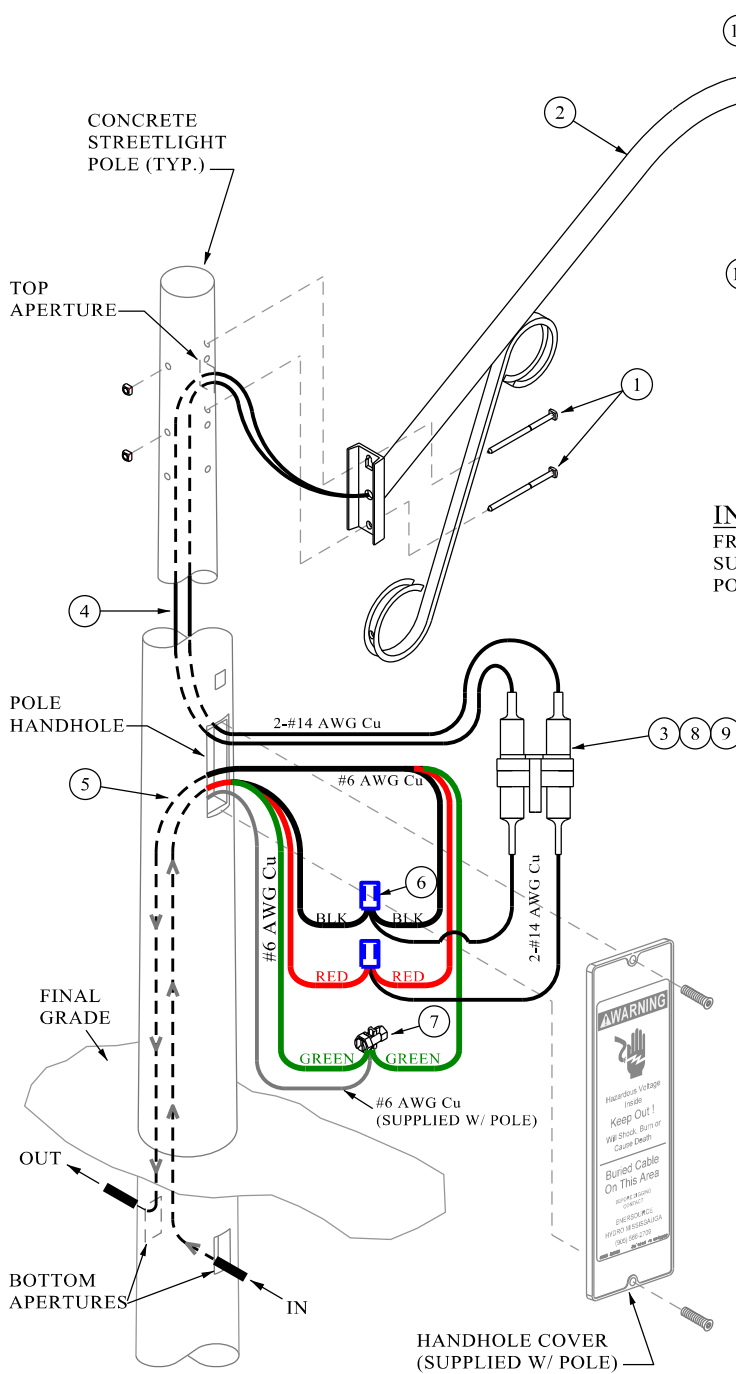

| BILL OF MATERIALS | | |
|-------------------|--|-----|
| ITEM# | DESCRIPTION | QTY |
| 1 | BOLT, MACHINE, 5/8" x 10" | 2 |
| 2 | BRACKET, LUMINAIRE, 6' | 1 |
| 3 | BOOT, INSULATING | 4 |
| 4 | CABLE, 2-#14 Cu SOLID, PVCJ, 600 V | ++ |
| 5 | CABLE, 3-#6 Cu STR, RWU90, XLPE, 1000 V | ++ |
| 6 | CONNECTOR, 14-2/0 GelCap | 2 |
| 7 | CONNECTOR, SPLIT BOLT | 1 |
| 8 | FUSE, CARTRIDGE, 10A | 2 |
| 9 | FUSE HOLDER, IN-LINE, DOUBLE POLE, 30A, 600V | 1 |
| 10 | City Approved LED Luminaire (as supplied by CoM approved luminaire supplier) | 1 |
| 11 | Adaptive Control Node (as supplied by CoM approved Node Supplier) | 1 |

++ - LENGTH/QUANTITY TO SUIT



**STREETLIGHTING - 240 V
U/G SYSTEM DESIGN - NO NEUTRAL
USING COACH LUMINAIRE**

INDIVIDUALLY CONTROLLED AND FUSED

| | | | |
|-----------|-----|------------|-----------------------|
| EFF. DATE | | SCALE | N.T.S. |
| REV. | 001 | 2025 09 12 | STANDARD No. 3100.030 |

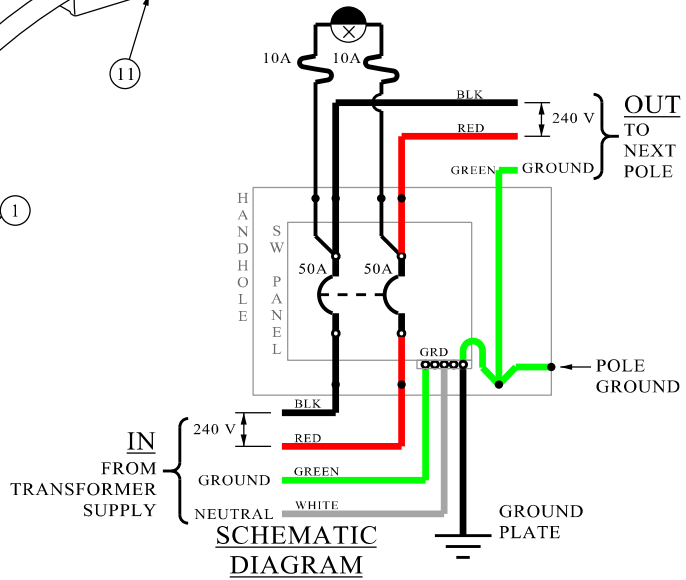
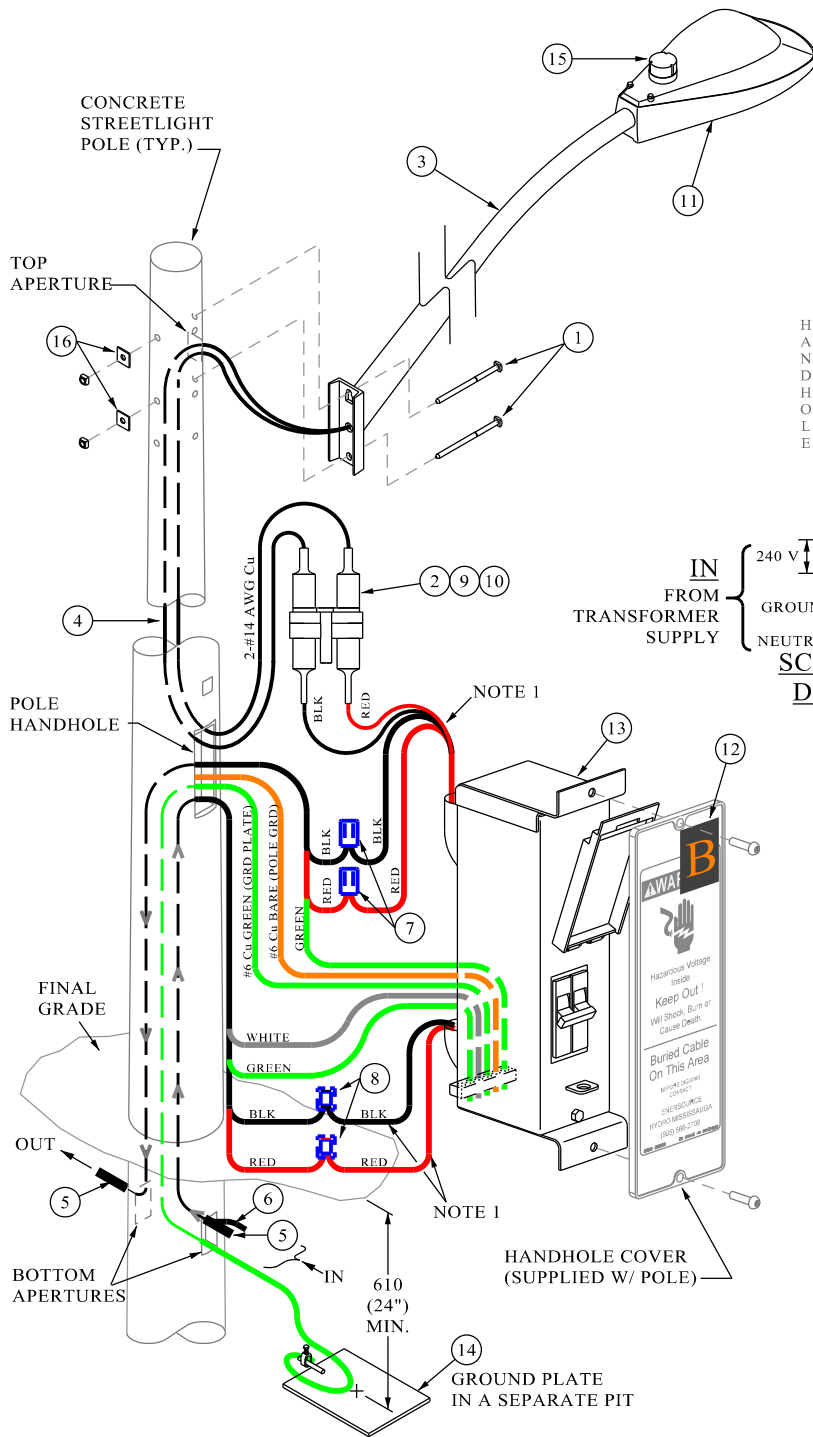

| BILL OF MATERIALS | | |
|-------------------|--|--------|
| ITEM# | DESCRIPTION | QTY |
| 1 | BOLT, MACHINE, 5/8" x 10" | 2 |
| 2 | BOOT, INSULATING | 4 |
| 3 | BRACKET, LUMINAIRE, 8' (TYP) | 1 |
| 4 | CABLE, 2-#14 Cu SOLID, PVCJ, 600 V | ++ |
| 5 | CABLE, 3C-#6 Cu STR, RWU90, XLPE, BLACK/RED/GREEN, 1000V | ++ |
| 6 | CABLE, 1C-#6 Cu STR, RWU90, XLPE, WHITE, 1000 V | ++ |
| 7 | CONNECTOR, BOLTED, 3-HOLE #14-#2/0 & #14-#6 C/W GEL CAP | 2 |
| 8 | CONNECTOR, COMPRESSION, CU, #6 - #6 AWG STRANDED | 2 |
| 9 | FUSE, CARTRIDGE, 10 A | 2 |
| 10 | FUSE HOLDER, IN-LINE, DOUBLE POLE, 30A, 600V | 1 |
| 11 | City Approved LED Luminaire (as supplied by CoM approved luminaire supplier) | 1 ONLY |
| 12 | MARKER, LETTER "B" | 1 |
| 13 | PANEL, SWITCH, IN-POLE, c/w 2-50 A BREAKER | 1 |
| 14 | PLATE, GROUND, 10"x16", CSA APPROVED | 1 |
| 15 | Adaptive Control Node (as supplied by CoM approved Node Supplier) | 1 |
| 16 | WASHER, SQ, FLAT, 2"x2" | 2 |

++ - LENGTH/QUANTITY/SIZE TO SUIT

NOTE

1. LEAVE FLEXIBLE BREAKER LEADS LONGER THAN CABLE TAILS TO FACILITATE EASIER BREAKER INSTALLATION IN HANDHOLE.
2. SEE POLE TYPE SPECIFICATIONS (REF. STD. 3100.070, 3100.080, 3100.090, 3100.100, 3100.110, 3100.120 AND 3100.150).



STREET LIGHTING
STREETLIGHTING - 240 V
U/G SYSTEM DESIGN - NO NEUTRAL
WITH BREAKER

| | | | |
|-----------|-----|------------|-----------------------|
| EFF. DATE | | SCALE | N.T.S. |
| REV. | 001 | 2002-01-01 | STANDARD No. 3100.050 |

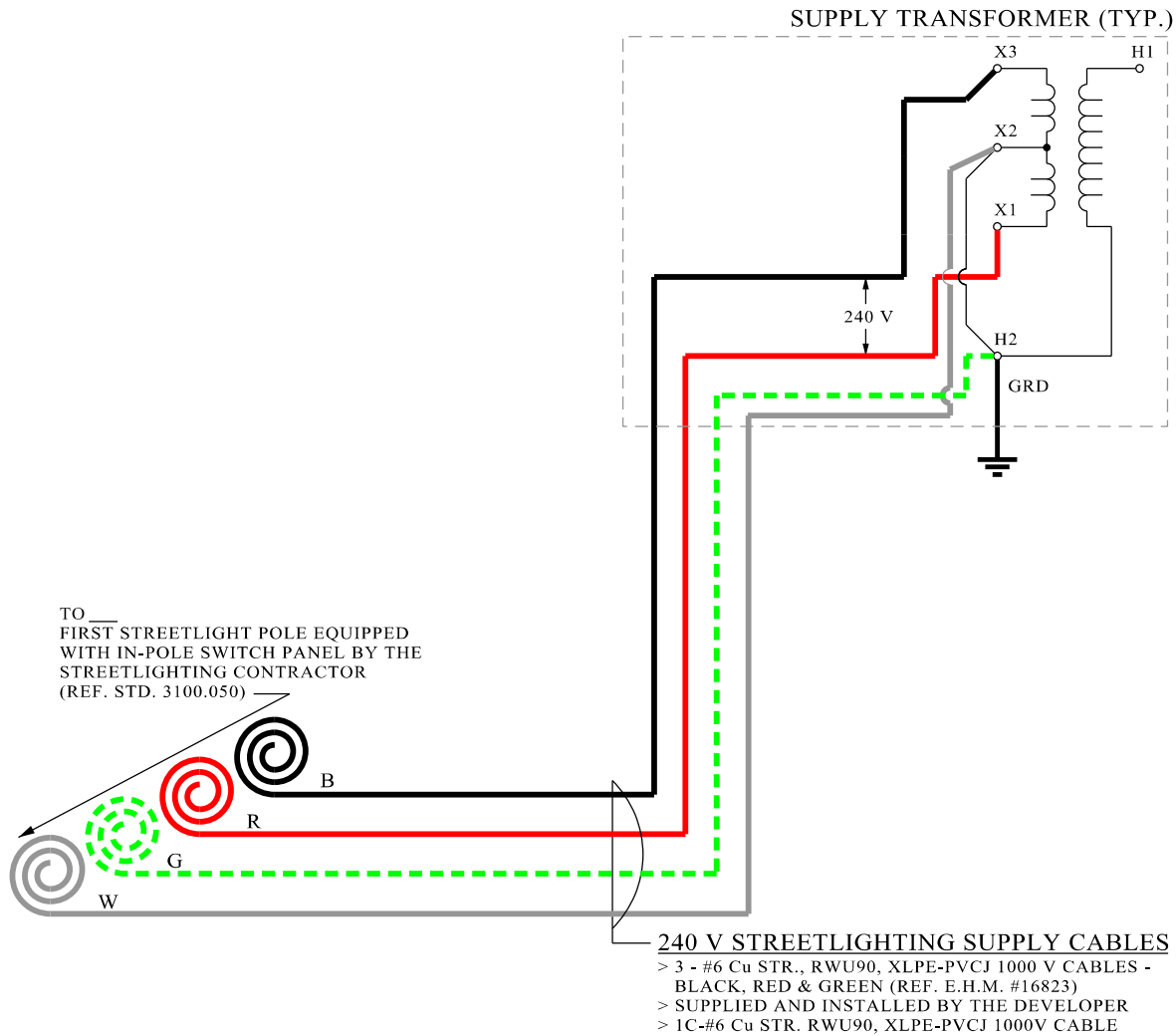

NOTES:

1. THE CABLES AND COMPRESSION LUGS SHALL BE OF A TYPE APPROVED BY ALECTRA UTILITIES
2. THE DEVELOPER SHALL SUPPLY COMPRESSION LUGS AT TRANSFORMER SUPPLY POINT.
3. STREETLIGHTING CABLES SHALL BE INSTALLED IN A 50 mm PVC DB2/ES2 DIRECT BURIED DUCT.



**STREET LIGHTING
SCHEMATIC FOR
STREETLIGHTING SUPPLY-240 V**

| | | | |
|-----------|-----|------------|-----------------------|
| EFF. DATE | | SCALE | N.T.S. |
| REV. | 001 | 2026 01 12 | STANDARD No. 3100.055 |

TYPICAL PEDESTRAIN POLE

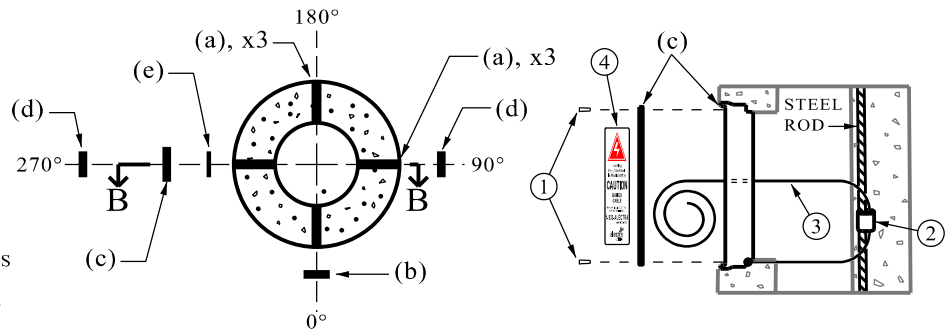
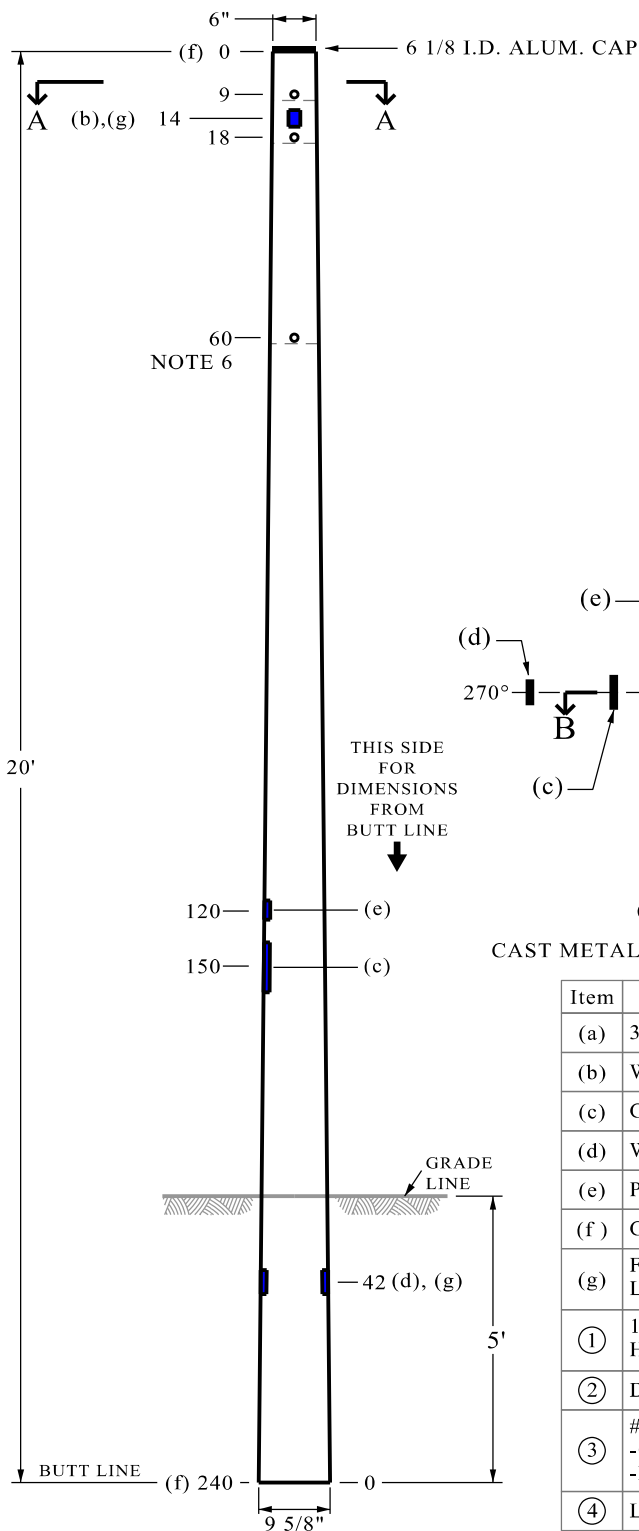

SECTION A-A

(STEEL RODS NOT SHOWN)

SECTION B-B

2.5" x 8" HANDHOLE - ITEM (c)

CAST METALLIC HANDHOLE FRAME AND COVER, 2.5"x 8"

| Item | Description | Qty |
|------|--|---------|
| (a) | 3/4" DIAMETER FORMED THROUGH HOLE | 6 |
| (b) | WIRING APERTURE, 2.25" X 3.5" (POLE TOP) | 1 |
| (c) | CAST METALLIC HANDHOLE FRAME AND COVER, 3.5"x 10.5" | 1 |
| (d) | WIRING APERTURE, 2.5" X 5" (BELOW GRADE LINE) | 2 |
| (e) | POLE IDENTIFICATION PLATE | 1 |
| (f) | CAPSEAL X75 OR APPROVED EQUIVALENT (FULL LENGTH) | 2 coats |
| (g) | FISH WIRE, 0.046" DIA. (MINIMUM) GALVANIZED STEEL OR LDC APPROVED EQUIVALENT | ++ |
| ① | 1/4" - 20 x 3/4" TAMPER PROOF ALLEN KEY BUTTON PAN HEAD STAINLESS STEEL | 2 |
| ② | DOUBLE CRIMP CONNECTOR | 1 |
| ③ | #6 AWG (MINIMUM) STRANDED COPPER WIRE: -CRIMPED TO STEEL ROD AND HANDHOLE FRAME -EXTENDED 12" OUTSIDE HANDHOLE | ++ |
| ④ | LABEL PER ALECTRA STD. 5-1036 (LATEST REVISION) | 1 |

++ - LENGTH TO SUIT

NOTES:

1. ALL DIMENSIONS SHOWN ARE FROM TOP OF POLE (EXCEPT AS NOTED) AND MEASURED FROM CENTRE LINE.
2. ALL HOLES SHALL BE 3/4" IN DIAMETER.
3. IN ALL CASES, IDENTICAL HOLES SHALL BE PLACED 1" BELOW, AND 90° TO DIMENSIONED HOLES.
4. RACEWAYS SHALL BE 1.125" MINIMUM IN DIAMETER AND BE PROVIDED WITH FISH WIRE.
5. POLE SHALL BE PRESTRESSED AND BE MADE IN ACCORDANCE WITH CSA STD. A14 (LATEST EDITION).
6. THE PURPOSE OF THESE HOLES IS TO PREVENT SLING SLIPPAGE DURING MATERIAL HANDLING.



STREET LIGHTING
20 ft. (6.1 m) CLASS A
CSA SPUN, ROUND, CONCRETE
DISTRIBUTION POLE

| | | | |
|-----------|-----|------------|-----------------------|
| EFF. DATE | | SCALE | N.T.S. |
| REV. | 001 | 2026 01 21 | STANDARD No. 3100.070 |

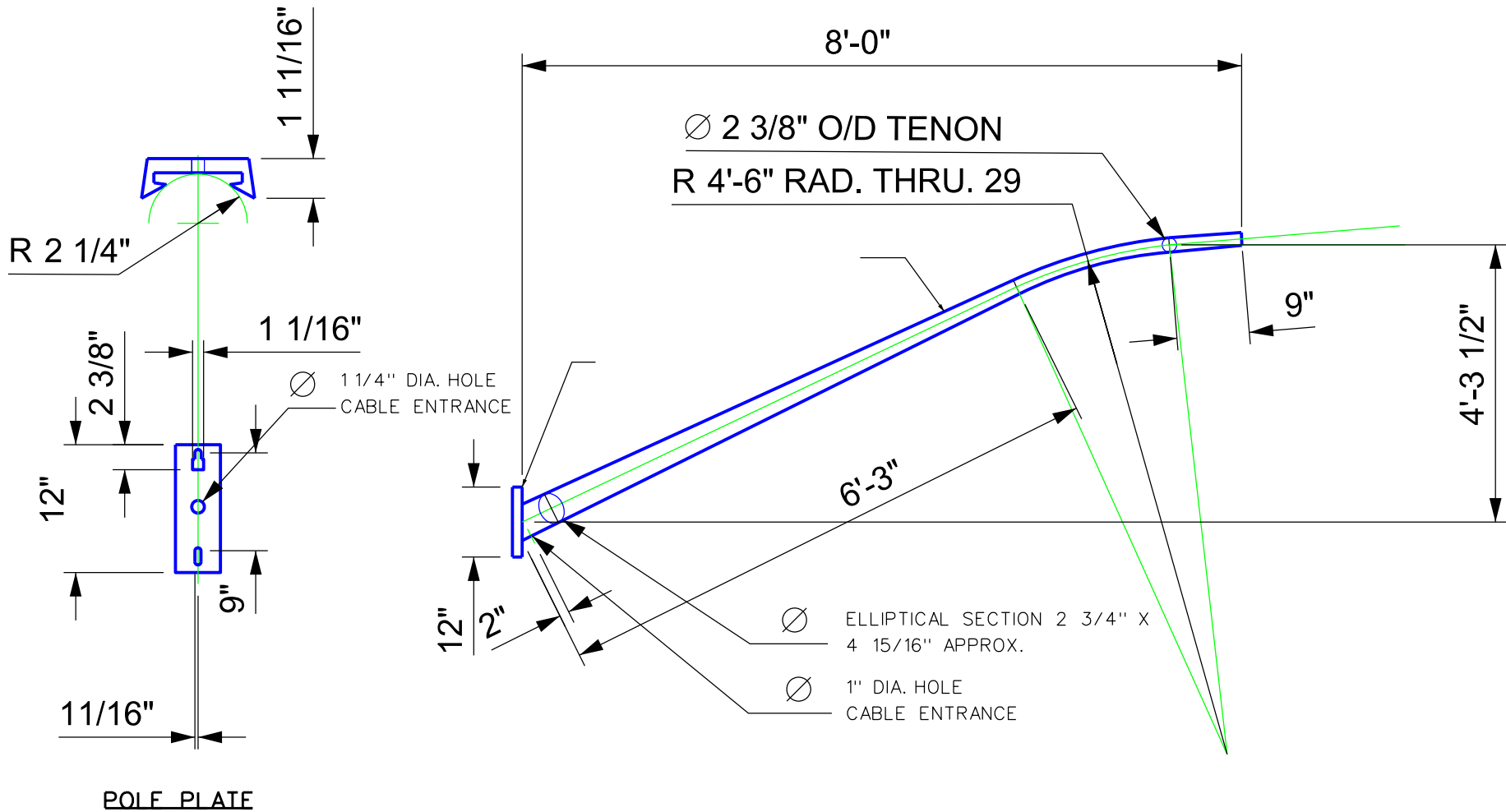

NOTES

1. ALL WELDING AS PER CSA W47.2
2. TEMP: T6
3. FINISH:RAL 6012
4. POLE PLATE PATTERN ACCOMIDATE 9" TO 10" HOLE SEPARATION



STREET LIGHTING
TYPICAL
TAPERED ELLIPTICAL 8' BRACKET

| | | | |
|------------------|--|------------------------------|---------------|
| EFF. DATE | | SCALE | N.T.S. |
| REV. | | STANDARD No. 3100.075 | |

TYPICAL STREET LIGHT STANDARD WITH IN-POLE BREAKER

-ONLY USED FOR THE FIRST POLE FROM POWER SOURCE

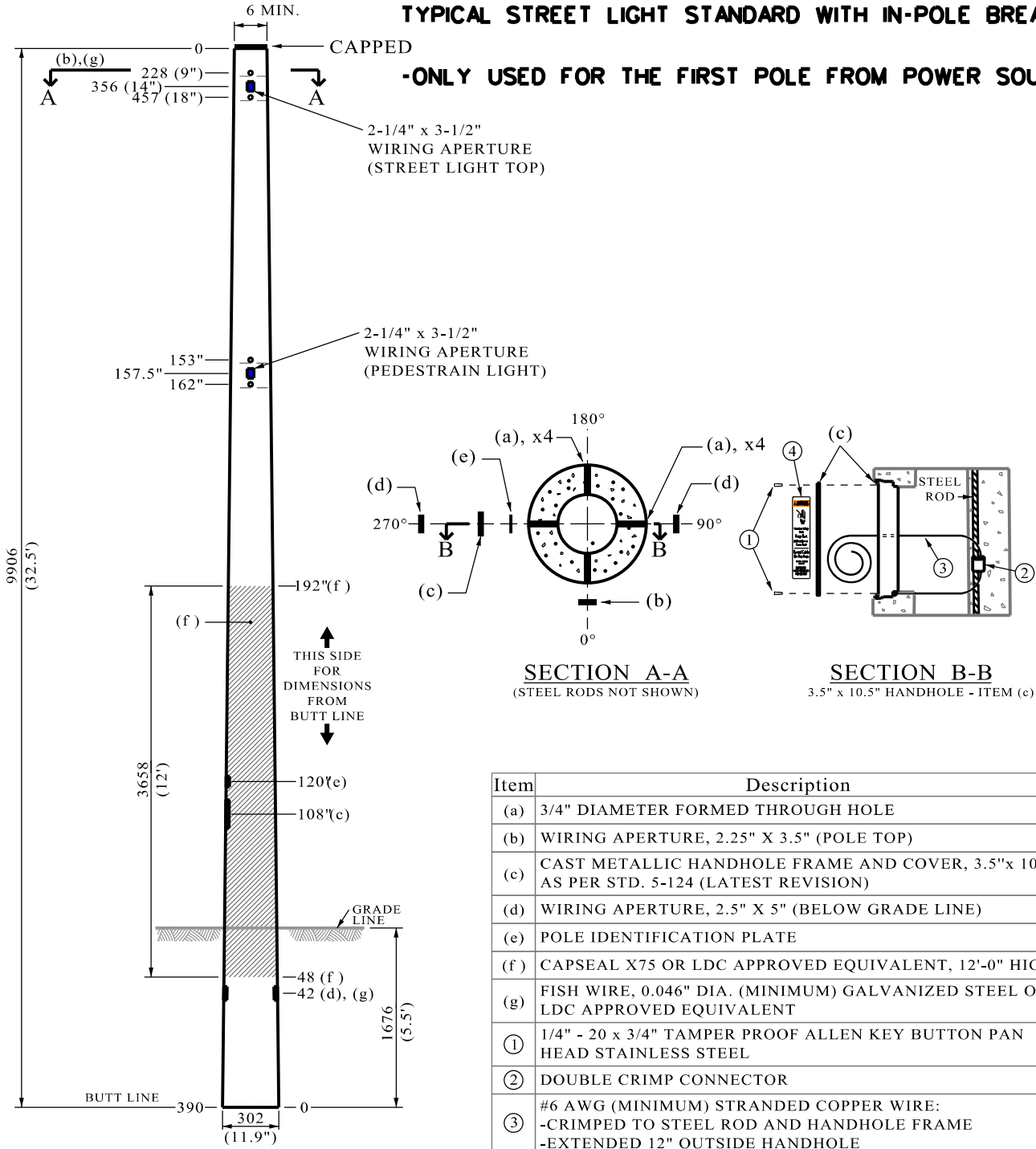

| Item | Description | Qty |
|------|--|---------|
| (a) | 3/4" DIAMETER FORMED THROUGH HOLE | 8 |
| (b) | WIRING APERTURE, 2.25" X 3.5" (POLE TOP) | 1 |
| (c) | CAST METALLIC HANDHOLE FRAME AND COVER, 3.5"x 10.5" AS PER STD. 5-124 (LATEST REVISION) | 1 |
| (d) | WIRING APERTURE, 2.5" X 5" (BELOW GRADE LINE) | 2 |
| (e) | POLE IDENTIFICATION PLATE | 1 |
| (f) | CAPSEAL X75 OR LDC APPROVED EQUIVALENT, 12'-0" HIGH | 2 coats |
| (g) | FISH WIRE, 0.046" DIA. (MINIMUM) GALVANIZED STEEL OR LDC APPROVED EQUIVALENT | ++ |
| ① | 1/4" - 20 x 3/4" TAMPER PROOF ALLEN KEY BUTTON PAN HEAD STAINLESS STEEL | 2 |
| ② | DOUBLE CRIMP CONNECTOR | 1 |
| ③ | #6 AWG (MINIMUM) STRANDED COPPER WIRE: -CRIMPED TO STEEL ROD AND HANDHOLE FRAME -EXTENDED 12" OUTSIDE HANDHOLE | ++ |
| ④ | WARNING LABEL AS PER STD. 5-125 (LATEST REVISION) | 1 |

++ - LENGTH TO SUIT

NOTES:

- ALL DIMENSIONS SHOWN ARE FROM TOP OF POLE (EXCEPT AS NOTED) AND MEASURED FROM CENTRE LINE.
- ALL HOLES SHALL BE 3/4" IN DIAMETER.
- IN ALL CASES, IDENTICAL HOLES SHALL BE PLACED 1" BELOW, AND 90° TO DIMENSIONED HOLES.
- RACEWAYS SHALL BE 2" MINIMUM IN DIAMETER AND BE PROVIDED WITH FISH WIRE.
- POLE SHALL BE PRESTRESSED AND BE MADE IN ACCORDANCE WITH CSA STD. A14 (LATEST EDITION).



STREET LIGHTING
32.5 ft. (9.9 m) Class A
CSA SPUN ROUND CONCRETE
STREET LIGHTING CLASS POLE

| | | | |
|-----------|-----|------------|-----------------------|
| EFF. DATE | | SCALE | N.T.S. |
| REV. | 001 | 2025 09 12 | STANDARD No. 3100.080 |

TYPICAL STREET LIGHT STANDARD

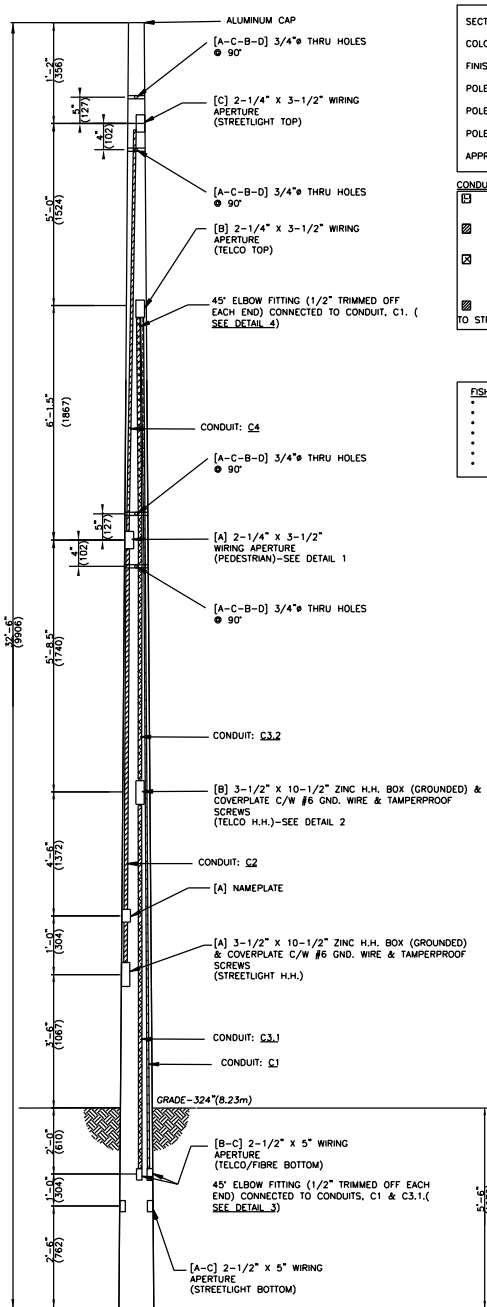

| | |
|---------------|---------------------|
| SECTION: | ROUND |
| COLOR: | REGULAR |
| FINISH: | MOLD |
| POLE TOP: | 6 1/2" (165mm) DIA. |
| POLE BUTT: | 12.4" (315mm DIA.) |
| POLE LENGTH: | 32' 6" (9.91m) |
| APPROX. WGT.: | 1,980 lbs. |

| | |
|-------------------------|--|
| CONDUIT DETAILS: | |
| C1: | 1" CONDUIT RUNNING FROM FIBRE BOTTOM APERTURE(C) TO TELCO TOP APERTURE(B). |
| C2: | 1" CONDUIT RUNNING FROM STREETLIGHT H.H.(A) TO PEDESTRIAN APERTURE(A). |
| C3.1/C3.2: | 1.25" CONDUIT RUNNING FROM TELCO BOTTOM APERTURE(B) TO TELCO H.H.(B) TO TELCO TOP APERTURE(C). |
| C4: | 1" CONDUIT RUNNING FROM PEDESTRIAN APERTURE(A) TO STREETLIGHT TOP APERTURE(C). |

- FISHWIRE REQUIRED FOR:**
- STREETLIGHT BOTTOM APERTURES TO STREETLIGHT H.H.
 - TELCO BOTTOM APERTURE TO TELCO H.H.
 - FIBRE BOTTOM APERTURE AND TELCO TOP APERTURE.
 - STREETLIGHT H.H. AND TELCO H.H.
 - STREETLIGHT H.H. AND PEDESTRIAN APERTURE.
 - STREETLIGHT H.H. AND STREETLIGHT TOP APERTURE.
 - TELCO H.H. AND TELCO TOP APERTURE.

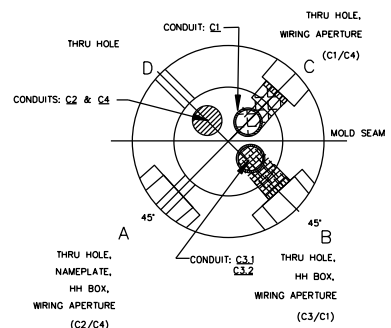

TOP VIEW

NOTES

1. ALL HOLES SHALL BE 3/4" DIAMETER
2. IN ALL CASES, IDENTICAL HOLES SHALL BE PLACED 1" BELOW, AND 90 DEGREES TO DIMENSIONED HOLES
3. POLE SHALL BE PRESTRESSED AND MADE IN ACCORDANCE WITH CSA STANDARDS A14-00 (OR LATEST EDITION) AND THIS DRAWING

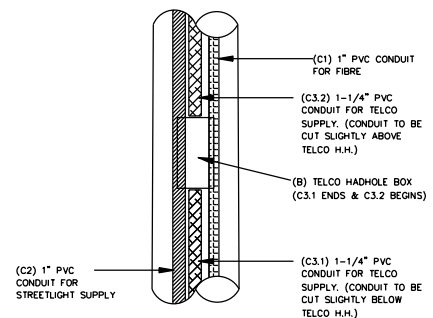

DETAIL 2
TELCO H.H.

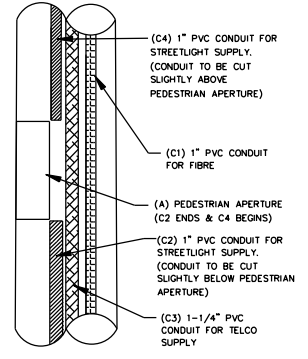

DETAIL 1
PEDESTRIAN APERTURE

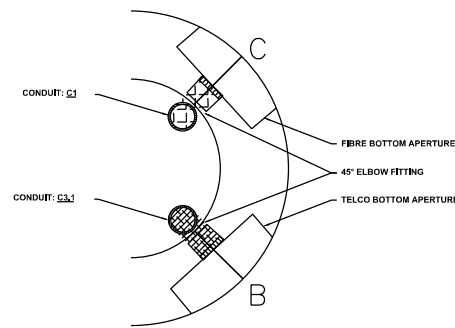

DETAIL 3

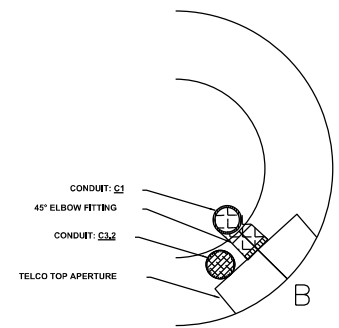

DETAIL 4



MISSISSAUGA

STREETLIGHTING

32.5' (9.9m) Class "B" CSA SPUN ROUND CONCRETE

| | | | | | |
|-----------|-----|------------|--------------|--------|----------|
| EFF. DATE | | SCALE | | N.T.S. | |
| REV. | 001 | 2025 09 12 | STANDARD No. | | 3100.085 |

TYPICAL STREET LIGHT STANDARD WITH IN-POLE BREAKER

- ONLY USED FOR THE FIRST POLE FROM POWER SOURCE

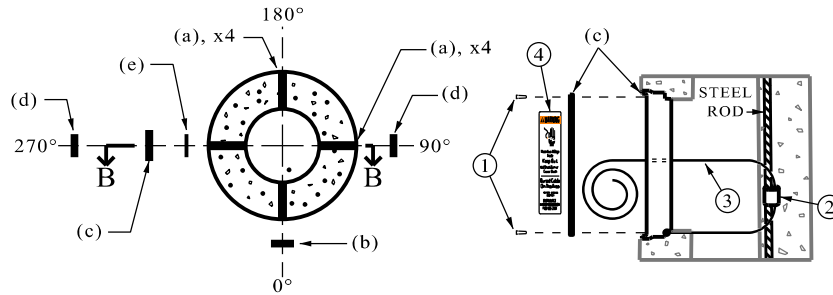
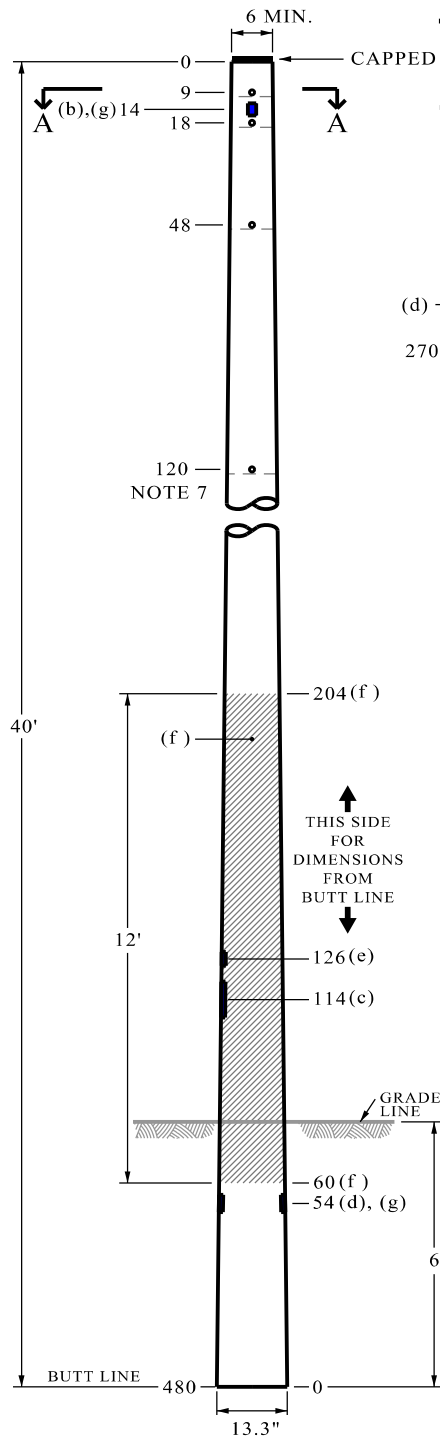

SECTION A-A
(STEEL RODS NOT SHOWN)

SECTION B-B
3.5" x 10.5" HANDHOLE - ITEM(c)

| Item | Description | Qty |
|------|--|---------|
| (a) | 3/4" DIAMETER FORMED THROUGH HOLE | 8 |
| (b) | WIRING APERTURE, 2.25" X 3.5" (POLE TOP) | 1 |
| (c) | CAST METALLIC HANDHOLE FRAME AND COVER, 3.5"x 10.5" AS PER STD. 5-124 (LATEST REVISION) | 1 |
| (d) | WIRING APERTURE, 2.5" X 5" (BELOW GRADE LINE) | 2 |
| (e) | POLE IDENTIFICATION PLATE | 1 |
| (f) | CAPSEAL X75 OR LDC APPROVED EQUIVALENT, 12'-0" HIGH | 2 coats |
| (g) | FISH WIRE, 0.046" DIA. (MINIMUM) GALVANIZED STEEL OR LDC APPROVED EQUIVALENT | ++ |
| ① | 1/4" - 20 x 3/4" TAMPER PROOF ALLEN KEY BUTTON PAN HEAD STAINLESS STEEL | 2 |
| ② | DOUBLE CRIMP CONNECTOR | 1 |
| ③ | #6 AWG (MINIMUM) STRANDED COPPER WIRE: -CRIMPED TO STEEL ROD AND HANDHOLE FRAME -EXTENDED 12" OUTSIDE HANDHOLE | ++ |
| ④ | WARNING LABEL AS PER STD. 5-125 (LATEST REVISION) | 1 |

++ - LENGTH TO SUIT

NOTES:

1. ALL DIMENSIONS SHOWN ARE FROM TOP OF POLE (EXCEPT AS NOTED) AND MEASURED FROM CENTRE LINE.
2. ALL HOLES SHALL BE 3/4" IN DIAMETER.
3. IN ALL CASES, IDENTICAL HOLES SHALL BE PLACED 1" BELOW, AND 90° TO DIMENSIONED HOLES.
4. RACEWAYS SHALL BE 2" MINIMUM IN DIAMETER AND BE PROVIDED WITH FISH WIRE.
5. POLE SHALL BE PRESTRESSED AND BE MADE IN ACCORDANCE WITH CSA STD. A14 (LATEST EDITION).
6. THE PURPOSE OF THESE HOLES IS TO PREVENT SLING SLIPPAGE DURING MATERIAL HANDLING.



STREET LIGHTING
40 ft. (12.2 m) Class B
CSA SPUN ROUND CONCRETE
STREET LIGHTING CLASS POLE

| | | | |
|-----------|-----|------------|-----------------------|
| EFF. DATE | | SCALE | N.T.S. |
| REV. | 001 | 2026 01 12 | STANDARD No. 3100.090 |

TYPICAL STREET LIGHT STANDARD

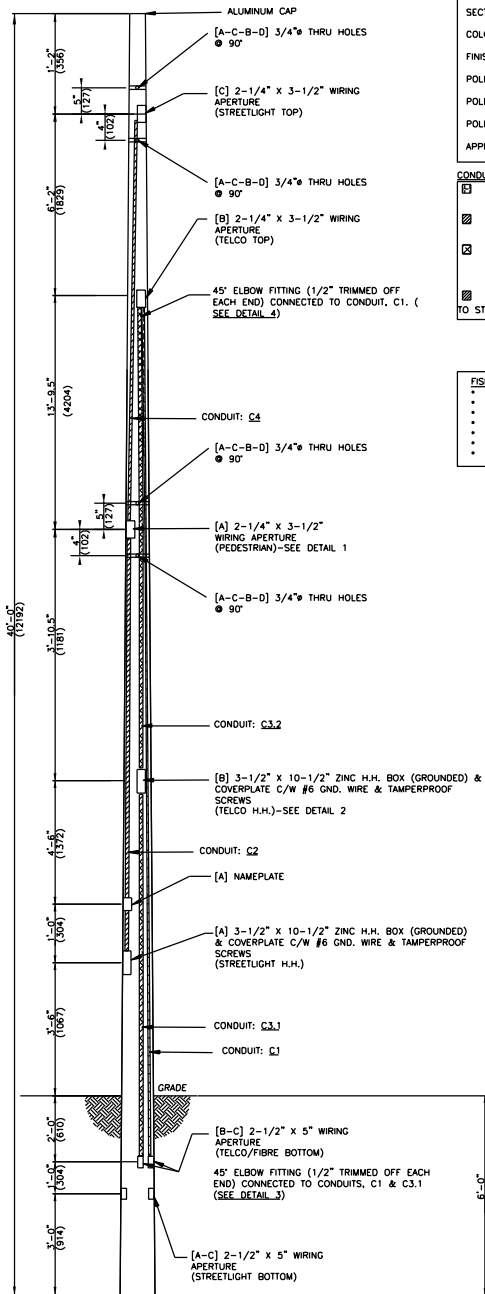

SECTION: ROUND
 COLOR: REGULAR
 FINISH: MOLD
 POLE TOP: 6 1/2" (165mm) DIA.
 POLE BUTT: 12.4" (315mm DIA.
 POLE LENGTH: 32' 6" (9.91m)
 APPROX. WGT.: 1,980 lbs.

CONDUIT DETAILS:
 C1: 1" CONDUIT RUNNING FROM FIBRE BOTTOM APERTURE(C) TO TELCO TOP APERTURE(B).
 C2: 1" CONDUIT RUNNING FROM STREETLIGHT H.H.(A) TO PEDESTRIAN APERTURE(A).
 C3.1/C3.2: 1.25" CONDUIT RUNNING FROM TELCO BOTTOM APERTURE(B) TO TELCO H.H.(B) TO TELCO TOP APERTURE(B).
 C4: 1" CONDUIT RUNNING FROM PEDESTRIAN APERTURE(A) TO STREETLIGHT TOP APERTURE(C).

FISHWIRE REQUIRED FOR:
 • STREETLIGHT BOTTOM APERTURES TO STREETLIGHT H.H.
 • TELCO BOTTOM APERTURE TO TELCO H.H.
 • FIBRE BOTTOM APERTURE AND TELCO TOP APERTURE.
 • STREETLIGHT H.H. AND TELCO H.H.
 • STREETLIGHT H.H. AND PEDESTRIAN APERTURE.
 • STREETLIGHT H.H. AND STREETLIGHT TOP APERTURE.
 • TELCO H.H. AND TELCO TOP APERTURE.

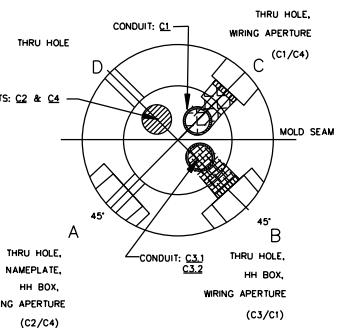

TOP VIEW

NOTES

1. ALL HOLES SHALL BE 3/4" DIAMETER
2. IN ALL CASES, IDENTICAL HOLES SHALL BE PLACED 1" BELOW, AND 90 DEGREES TO DIMENSIONED HOLES
3. POLE SHALL BE PRESTRESSED AND MADE IN ACCORDANCE WITH CSA STANDARDS A14-00 (OR LATEST EDITION) AND THIS DRAWING

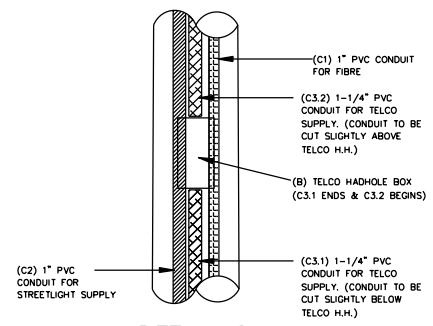

DETAIL 2
TELCO H.H.

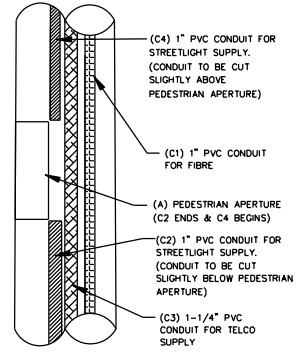

DETAIL 1
PEDESTRIAN APERTURE

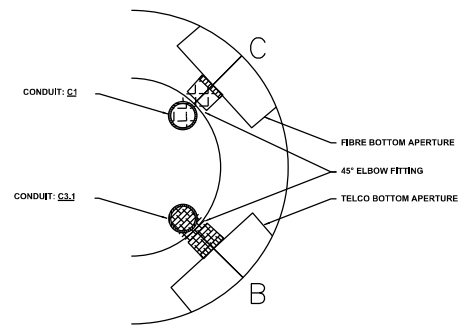

DETAIL 3

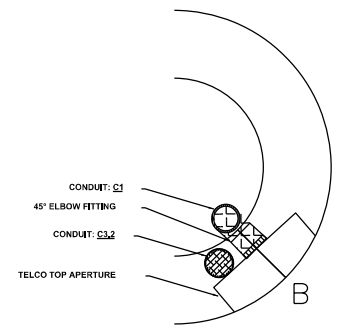

DETAIL 4



STREETLIGHTING

40' (12.2m) Class "B" CSA SPUN ROUND CONCRETE

| | | | |
|-----------|-----|------------|-----------------------|
| EFF. DATE | | SCALE | N.T.S. |
| REV. | 001 | 2025 09 12 | STANDARD No. 3100.095 |

TYPICAL STREET LIGHT POLE WITH IN-POLE BREAKER

- ONLY USED FOR THE FIRST POLE FROM POWER SOURCE

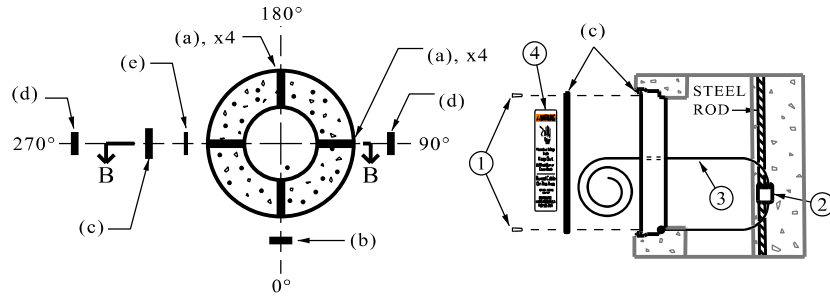
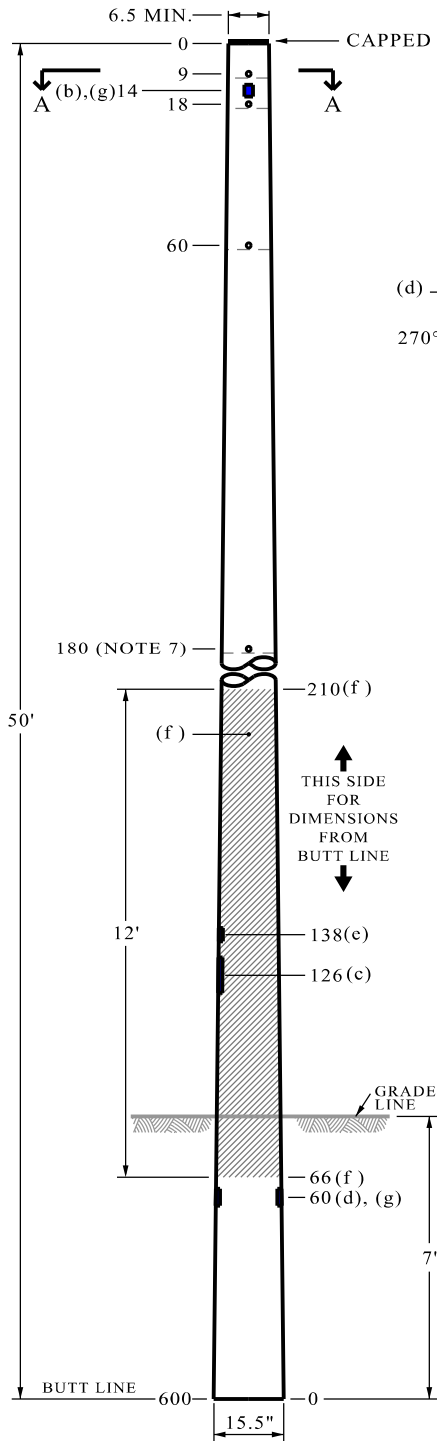

SECTION A-A
(STEEL RODS NOT SHOWN)

SECTION B-B
3.5" x 10.5" HANDHOLE - ITEM (c)

| Item | Description | Qty |
|------|--|---------|
| (a) | 3/4" DIAMETER FORMED THROUGH HOLE | 8 |
| (b) | WIRING APERTURE, 2.25" X 3.5" (POLE TOP) | 1 |
| (c) | CAST METALLIC HANDHOLE FRAME AND COVER, 3.5"x 10.5" AS PER STD. 5-124 (LATEST REVISION) | 1 |
| (d) | WIRING APERTURE, 2.5" X 5" (BELOW GRADE LINE) | 2 |
| (e) | POLE IDENTIFICATION PLATE | 1 |
| (f) | CAPSEAL X75 OR LDC APPROVED EQUIVALENT, 12'-0" HIGH | 2 coats |
| (g) | FISH WIRE, 0.046" DIA. (MINIMUM) GALVANIZED STEEL OR LDC APPROVED EQUIVALENT | ++ |
| ① | 1/4" - 20 x 3/4" TAMPER PROOF ALLEN KEY BUTTON PAN HEAD STAINLESS STEEL | 2 |
| ② | DOUBLE CRIMP CONNECTOR | 1 |
| ③ | #6 AWG (MINIMUM) STRANDED COPPER WIRE: -CRIMPED TO STEEL ROD AND HANDHOLE FRAME -EXTENDED 12" OUTSIDE HANDHOLE | ++ |
| ④ | WARNING LABEL AS PER STD. 5-125 (LATEST REVISION) | 1 |

++ - LENGTH TO SUIT

NOTES:

- ALL DIMENSIONS SHOWN ARE FROM TOP OF POLE (EXCEPT AS NOTED) AND MEASURED FROM CENTRE LINE.
- ALL HOLES SHALL BE 3/4" IN DIAMETER.
- IN ALL CASES, IDENTICAL HOLES SHALL BE PLACED 1" BELOW, AND 90° TO DIMENSIONED HOLES.
- RACEWAYS SHALL BE 2" MINIMUM IN DIAMETER AND BE PROVIDED WITH FISH WIRE.
- POLE SHALL BE PRESTRESSED AND BE MADE IN ACCORDANCE WITH CSA STD. A14 (LATEST EDITION).
- THE PURPOSE OF THESE HOLES IS TO PREVENT SLING SLIPPAGE DURING MATERIAL HANDLING.



STREET LIGHTING
50 ft. (15.2 m) Class D
CSA SPUN ROUND CONCRETE
STREET LIGHTING CLASS POLE

| | | | |
|-----------|-----|------------|-----------------------|
| EFF. DATE | | SCALE | N.T.S. |
| REV. | 001 | 2025 09 12 | STANDARD No. 3100.100 |

TYPICAL STREET LIGHT STANDARD

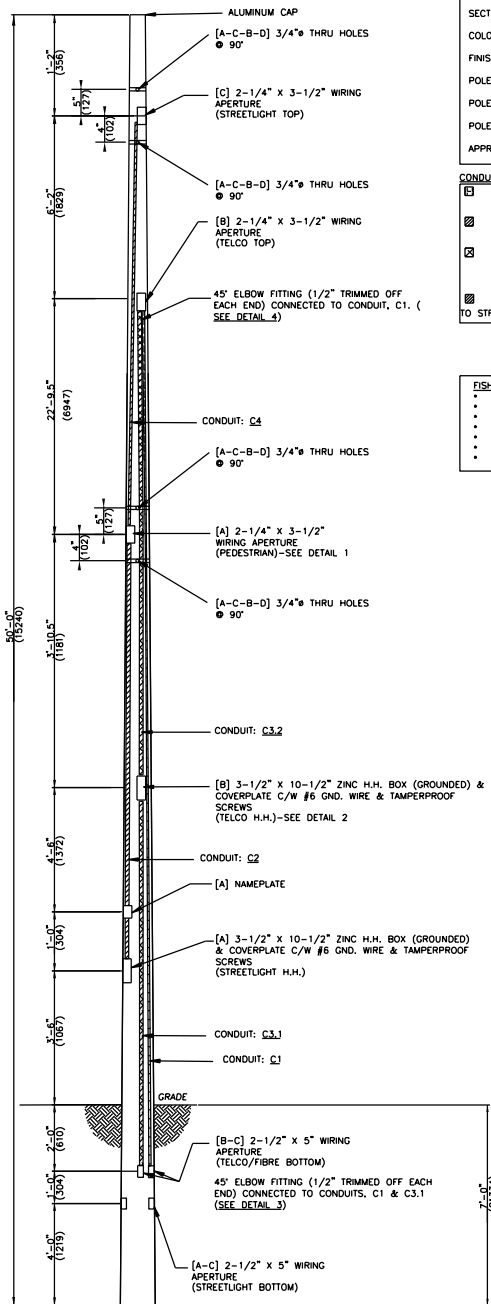

SECTION: ROUND
 COLOR: REGULAR
 FINISH: MOLD
 POLE TOP: 6 1/2" (165mm) DIA.
 POLE BUTT: 12.4" (315mm DIA.)
 POLE LENGTH: 32' 6" (9.91m)
 APPROX. WGT.: 1,980 lbs.

CONDUIT DETAILS:

- ☐ C1: 1" CONDUIT RUNNING FROM FIBRE BOTTOM APERTURE(C) TO TELCO TOP APERTURE(B).
- ☐ C2: 1" CONDUIT RUNNING FROM STREETLIGHT H.H.(A) TO PEDESTRIAN APERTURE(A).
- ☐ C3.1/C3.2: 1.25" CONDUIT RUNNING FROM TELCO BOTTOM APERTURE(B) TO TELCO H.H.(B) TO TELCO TOP APERTURE(B).
- ☐ C4: 1" CONDUIT RUNNING FROM PEDESTRIAN APERTURE(A) TO STREETLIGHT TOP APERTURE(C).

FISHWIRE REQUIRED FOR:

- STREETLIGHT BOTTOM APERTURES TO STREETLIGHT H.H.
- TELCO BOTTOM APERTURE TO TELCO H.H.
- FIBRE BOTTOM APERTURE AND TELCO TOP APERTURE.
- STREETLIGHT H.H. AND TELCO H.H.
- STREETLIGHT H.H. AND PEDESTRIAN APERTURE.
- STREETLIGHT H.H. AND STREETLIGHT TOP APERTURE.
- TELCO H.H. AND TELCO TOP APERTURE.

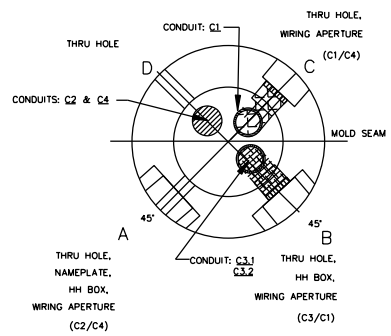

TOP VIEW

NOTES

1. ALL HOLES SHALL BE 3/4" DIAMETER
2. IN ALL CASES, IDENTICAL HOLES SHALL BE PLACED 1" BELOW, AND 90 DEGREES TO DIMENSIONED HOLES
3. POLE SHALL BE PRESTRESSED AND MADE IN ACCORDANCE WITH CSA STANDARDS A14-00 (OR LATEST EDITION) AND THIS DRAWING

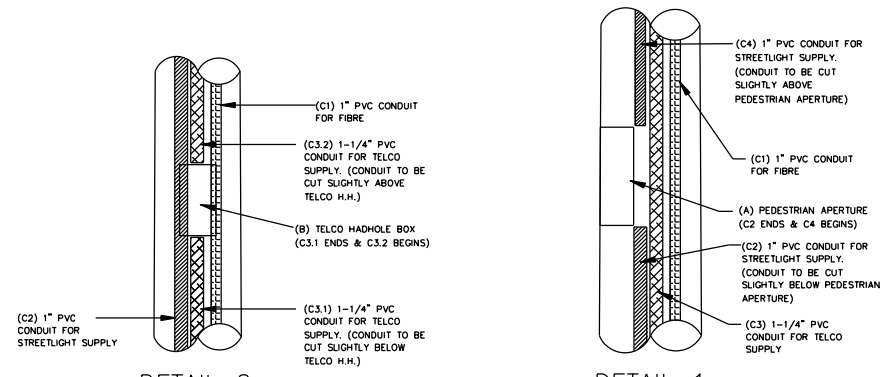

DETAIL 2
TELCO H.H.

DETAIL 1
PEDESTRIAN APERTURE

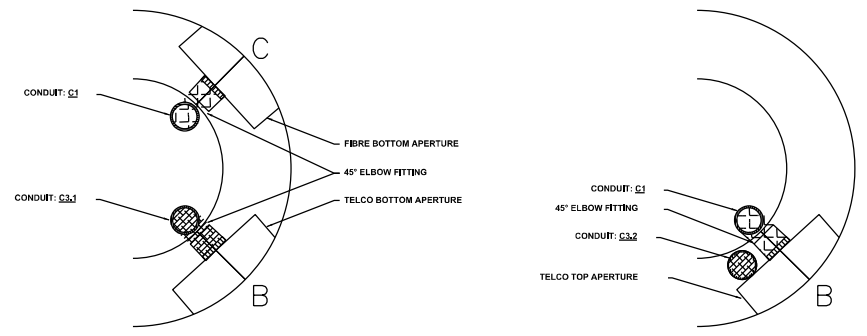

DETAIL 3

DETAIL 4



STREETLIGHTING

50' (15.2m) Class "B" CSA SPUN ROUND CONCRETE

| | | | |
|-----------|-----|------------|-----------------------|
| EFF. DATE | | SCALE | N.T.S. |
| REV. | 001 | 2025 09 12 | STANDARD No. 3100.105 |

TYPICAL DECORATIVE STREET LIGHT STANDARD WITH IN-POLE BREAKER

-ONLY USED FOR THE FIRST POLE FROM POWER SOURCE

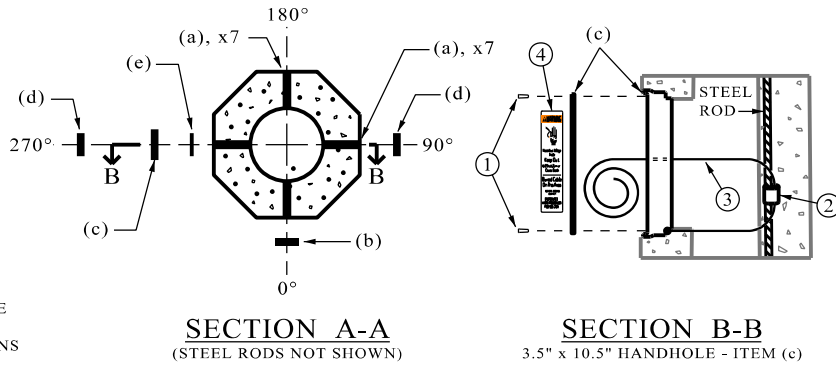
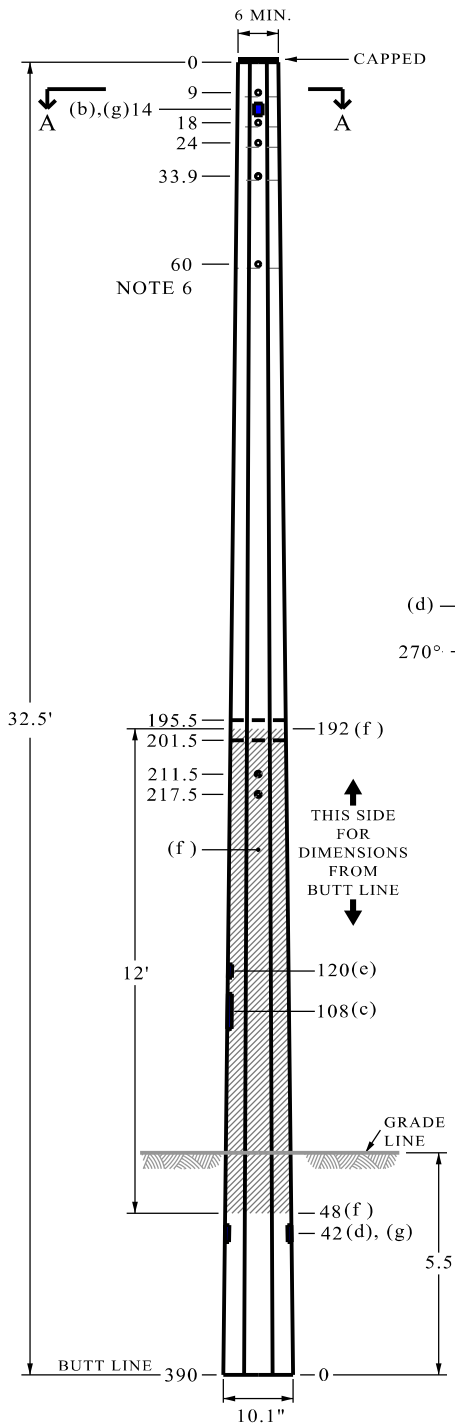

| Item | Description | Qty |
|------|--|---------|
| (a) | 3/4" DIAMETER FORMED THROUGH HOLE | 14 |
| (b) | WIRING APERTURE, 2.25" X 3.5" (POLE TOP) | 1 |
| (c) | CAST METALLIC HANDHOLE FRAME AND COVER, 3.5"x 10.5" AS PER STD. 5-124 (LATEST REVISION) | 1 |
| (d) | WIRING APERTURE, 2.5" X 5" (BELOW GRADE LINE) | 2 |
| (e) | POLE IDENTIFICATION PLATE | 1 |
| (f) | CAPSEAL X75 OR LDC APPROVED EQUIVALENT, 12'-0" HIGH | 2 coats |
| (g) | FISH WIRE, 0.046" DIA. (MINIMUM) GALVANIZED STEEL OR LDC APPROVED EQUIVALENT | ++ |
| ① | 1/4" - 20 x 3/4" TAMPER PROOF ALLEN KEY BUTTON PAN HEAD STAINLESS STEEL | 2 |
| ② | DOUBLE CRIMP CONNECTOR | 1 |
| ③ | #6 AWG (MINIMUM) STRANDED COPPER WIRE: -CRIMPED TO STEEL ROD AND HANDHOLE FRAME -EXTENDED 12" OUTSIDE HANDHOLE | ++ |
| ④ | WARNING LABEL AS PER STD. 5-125 (LATEST REVISION) | 1 |

++ - LENGTH TO SUIT

NOTES:

- ALL DIMENSIONS SHOWN ARE FROM TOP OF POLE (EXCEPT AS NOTED) AND MEASURED FROM CENTRE LINE.
- ALL HOLES SHALL BE 3/4" IN DIAMETER.
- IN ALL CASES, IDENTICAL HOLES SHALL BE PLACED 1" BELOW, AND 90° TO DIMENSIONED HOLES.
- RACEWAYS SHALL BE 2" MINIMUM IN DIAMETER AND BE PROVIDED WITH FISH WIRE.
- POLE SHALL BE PRESTRESSED AND BE MADE IN ACCORDANCE WITH CSA STD. A14 (LATEST EDITION).
- THE PURPOSE OF THESE HOLES IS TO PREVENT SLING SLIPPAGE DURING MATERIAL HANDLING.



STREET LIGHTING
 32.5 ft. (9.9 m) Class A
 CSA SPUN OCTAGONAL CONCRETE
 STREET LIGHTING CLASS POLE

| | | |
|---------------------|-----------------------|--------|
| EFF. DATE | SCALE | N.T.S. |
| REV. 001 2025 09 12 | STANDARD No. 3100.110 | |

TYPICAL DECORATIVE STREET LIGHT STANDARD

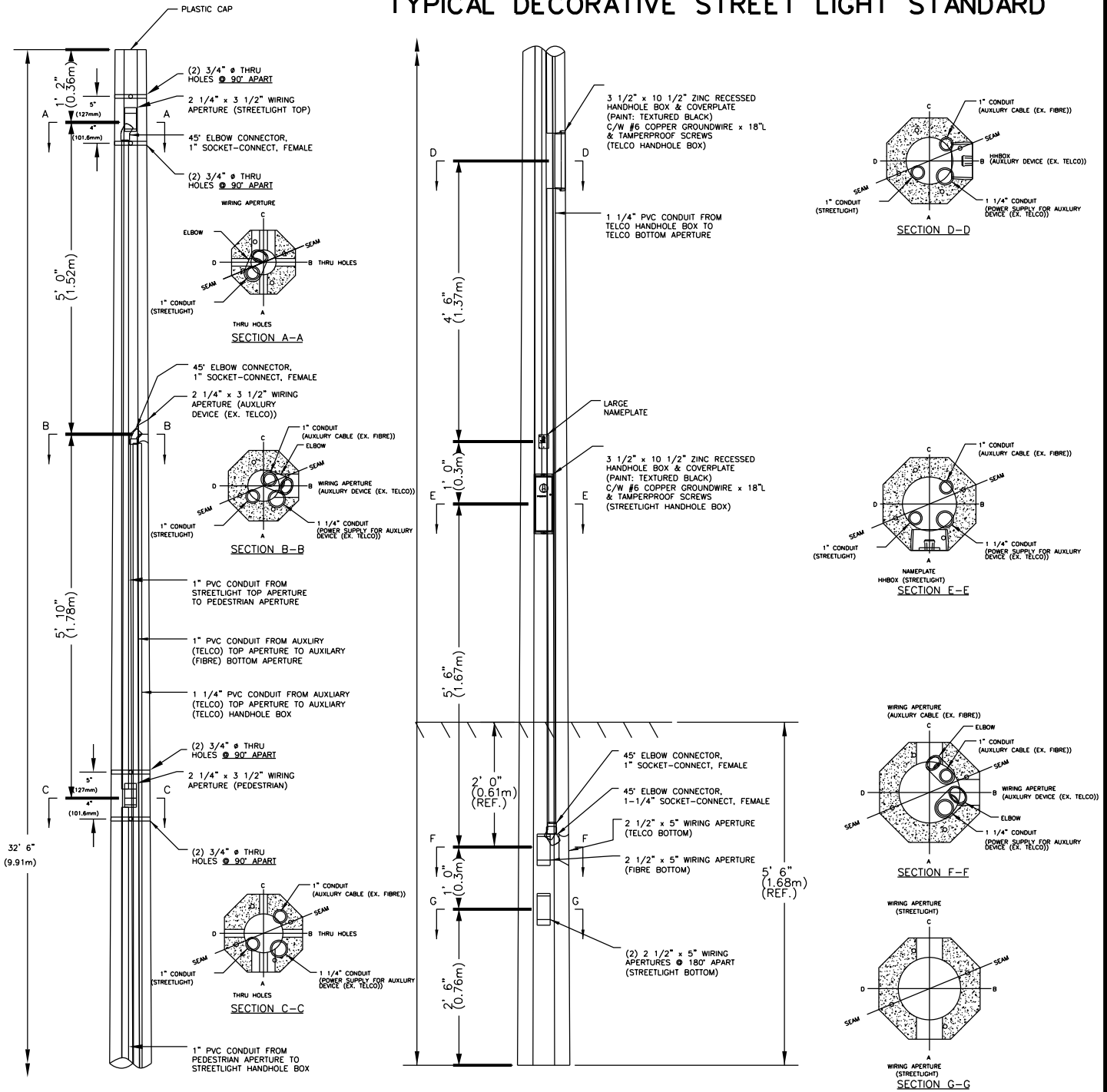

SECTION: OCTAGONAL
 COLOUR: ECLIPSE
 FINISH: POLISHED
 POLE TOP: 6" (152mm) FL/FL
 POLE BUTT: 10 1/16" (255mm) FL/FL
 POLE HEIGHT: 32' 6" (9.9m)
 APPROX. WGT.: 1,615 lbs. (733kg)

NOTES:

1. ALL DIMENSIONS SHOWN ARE FROM TOP OF POLE (EXCEPT AS NOTED) AND MEASURED FROM CENTRE LINE.
2. ALL HOLES SHALL BE 3/4" IN DIAMETER.
3. POLE SHALL BE PRESTRESSED AND BE MADE IN ACCORDANCE WITH CSA STD. A14 (LATEST EDITION).



STREET LIGHTING
BLACK CONCRETE POLISH OCTAGONAL
32.5 FT.(9.9M) CSA SPUN CLASS A

EFF. DATE

SCALE

N.T.S.

REV.

001

2025 09 13

STANDARD No. 3100.115

TYPICAL DECORATIVE STREET LIGHT STANDARD WITH IN-POLE BREAKER

-ONLY USED FOR THE FIRST POLE FROM POWER SOURCE

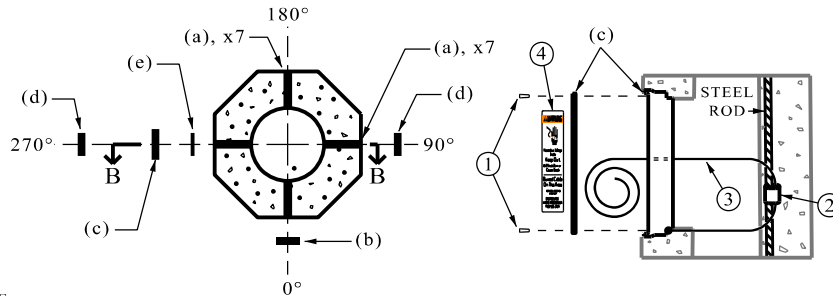
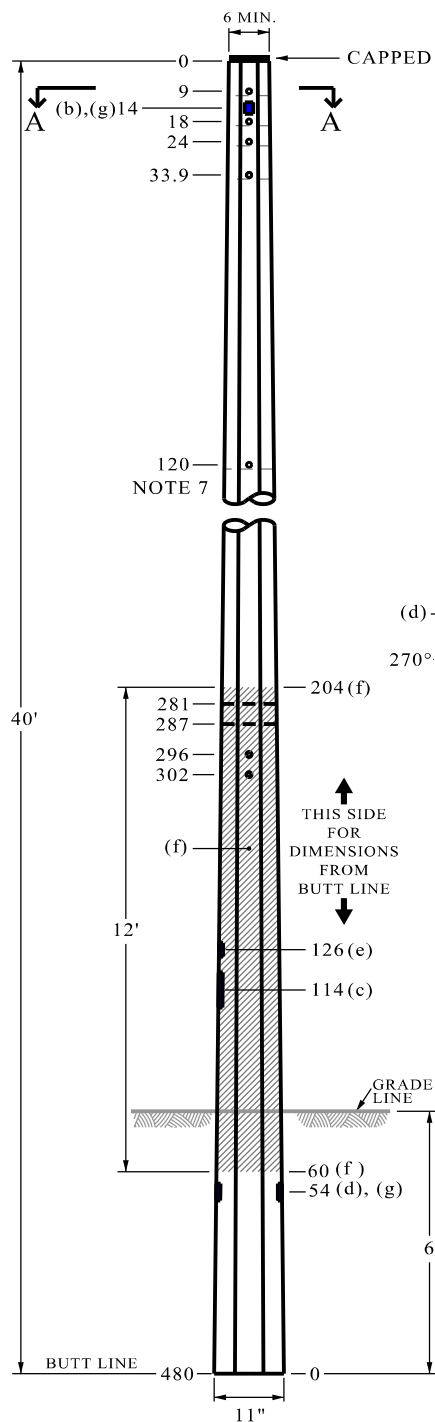

SECTION A-A
(STEEL RODS NOT SHOWN)

SECTION B-B
3.5" x 10.5" HANDHOLE - ITEM (c)

| Item | Description | Qty |
|------|--|---------|
| (a) | 3/4" DIAMETER FORMED THROUGH HOLE | 14 |
| (b) | WIRING APERTURE, 2.25" X 3.5" (POLE TOP) | 1 |
| (c) | CAST METALLIC HANDHOLE FRAME AND COVER, 3.5"x 10.5" AS PER STD. 5-124 (LATEST REVISION) | 1 |
| (d) | WIRING APERTURE, 2.5" X 5" (BELOW GRADE LINE) | 2 |
| (e) | POLE IDENTIFICATION PLATE | 1 |
| (f) | CAPSEAL X75 OR LDC APPROVED EQUIVALENT, 12'-0" HIGH | 2 coats |
| (g) | FISH WIRE, 0.046" DIA. (MINIMUM) GALVANIZED STEEL OR LDC APPROVED EQUIVALENT | ++ |
| ① | 1/4" - 20 x 3/4" TAMPER PROOF ALLEN KEY BUTTON PAN HEAD STAINLESS STEEL | 2 |
| ② | DOUBLE CRIMP CONNECTOR | 1 |
| ③ | #6 AWG (MINIMUM) STRANDED COPPER WIRE: -CRIMPED TO STEEL ROD AND HANDHOLE FRAME -EXTENDED 12" OUTSIDE HANDHOLE | ++ |
| ④ | WARNING LABEL AS PER STD. 5-125 (LATEST REVISION) | 1 |

++ - LENGTH TO SUIT

NOTES:

- ALL DIMENSIONS SHOWN ARE FROM TOP OF POLE (EXCEPT AS NOTED) AND MEASURED FROM CENTRE LINE.
- ALL HOLES SHALL BE 3/4" IN DIAMETER.
- IN ALL CASES, IDENTICAL HOLES SHALL BE PLACED 1" BELOW, AND 90° TO DIMENSIONED HOLES.
- RACEWAYS SHALL BE 2" MINIMUM IN DIAMETER AND BE PROVIDED WITH FISH WIRE.
- POLE SHALL BE PRESTRESSED AND BE MADE IN ACCORDANCE WITH CSA STD. A14 (LATEST EDITION).
- THE PURPOSE OF THESE HOLES IS TO PREVENT SLING SLIPPAGE DURING MATERIAL HANDLING.



STREET LIGHTING
40 ft. (12.2 m) Class B
CSA SPUN OCTAGONAL CONCRETE
STREET LIGHTING CLASS POLE

| | | | |
|-----------|-----|------------|-----------------------|
| EFF. DATE | | SCALE | N.T.S. |
| REV. | 001 | 2025 09 13 | STANDARD No. 3100.120 |

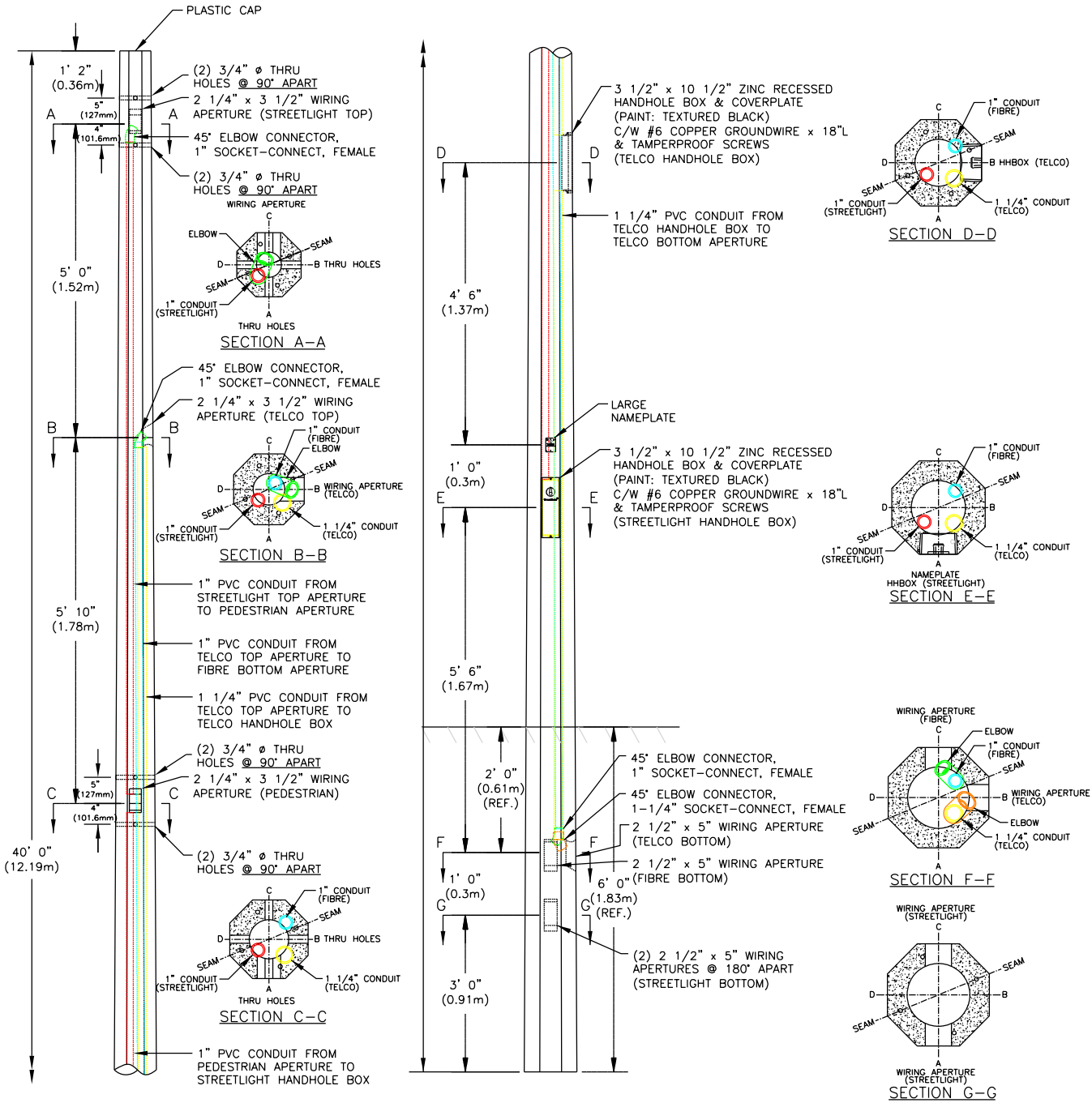

SECTION: OCTAGONAL
 COLOUR: ECLIPSE
 FINISH: POLISHED
 POLE TOP: 6" (152mm) FL/FL
 POLE BUTT: 11" (279mm) FL/FL
 POLE HEIGHT: 40' 0" (12.2m)
 APPROX. WGT.: 2,145 lbs. (973kg)

NOTES:

1. ALL DIMENSIONS SHOWN ARE FROM TOP OF POLE (EXCEPT AS NOTED) AND MEASURED FROM CENTRE LINE.
2. ALL HOLES SHALL BE 3/4" IN DIAMETER.
3. POLE SHALL BE PRESTRESSED AND BE MADE IN ACCORDANCE WITH CSA STD. A14 (LATEST EDITION).



STREET LIGHTING
 BLACK CONCRETE POLISH OCTAGONAL
 40 FT.(12.2M) CSA SPUN CLASS A

| | | | | | |
|-----------|-----|------------|-----------------------|--------|--|
| EFF. DATE | | SCALE | | N.T.S. | |
| REV. | 001 | 2025 09 13 | STANDARD No. 3100.125 | | |

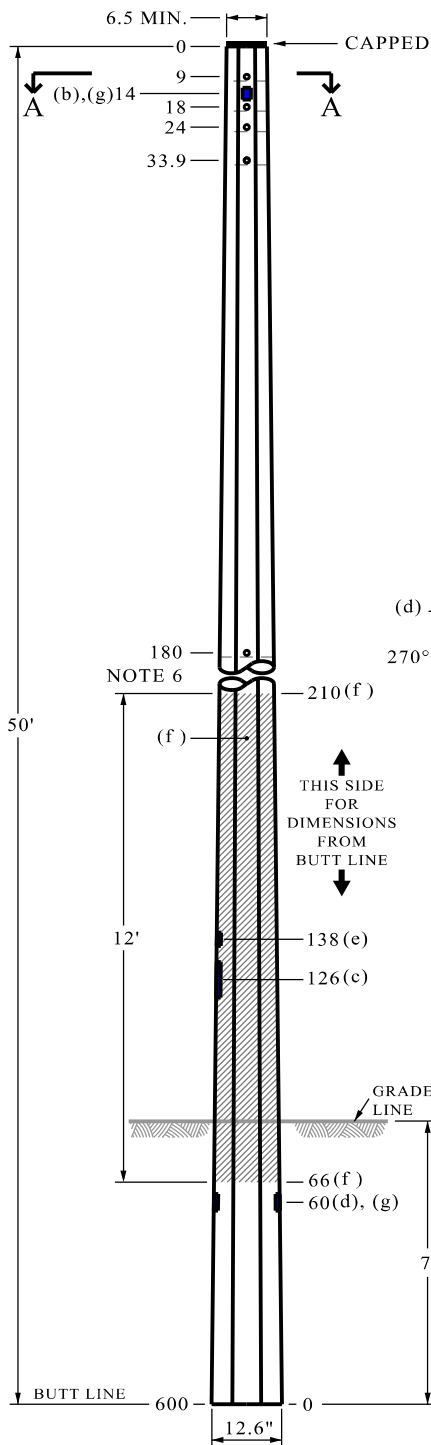

TYPICAL DECORATIVE STREET LIGHT STANDARD WITH IN-POLE BREAKER
-ONLY USED FOR THE FIRST POLE FROM POWER SOURCE

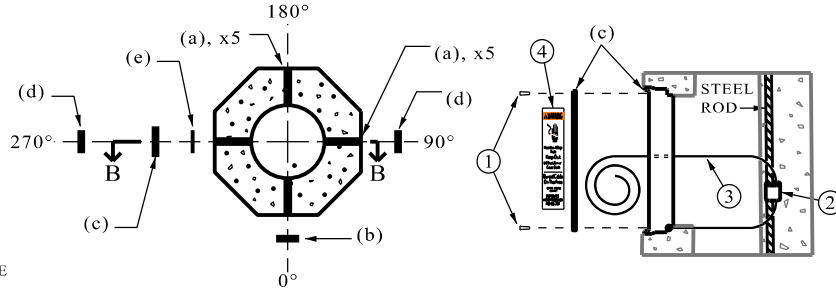

SECTION A-A
(STEEL RODS NOT SHOWN)

SECTION B-B
3.5" x 10.5" HANDHOLE - ITEM (c)

| Item | Description | Qty |
|------|--|---------|
| (a) | 3/4" DIAMETER FORMED THROUGH HOLE | 10 |
| (b) | WIRING APERTURE, 2.25" X 3.5" (POLE TOP) | 1 |
| (c) | CAST METALLIC HANDHOLE FRAME AND COVER, 3.5"x 10.5" AS PER STD. 5-124 (LATEST REVISION) | 1 |
| (d) | WIRING APERTURE, 2.5" X 5" (BELOW GRADE LINE) | 2 |
| (e) | POLE IDENTIFICATION PLATE | 1 |
| (f) | CAPSEAL X75 OR LDC APPROVED EQUIVALENT, 12'-0" HIGH | 2 coats |
| (g) | FISH WIRE, 0.046" DIA. (MINIMUM) GALVANIZED STEEL OR LDC APPROVED EQUIVALENT | ++ |
| ① | 1/4" - 20 x 3/4" TAMPER PROOF ALLEN KEY BUTTON PAN HEAD STAINLESS STEEL | 2 |
| ② | DOUBLE CRIMP CONNECTOR | 1 |
| ③ | #6 AWG (MINIMUM) STRANDED COPPER WIRE: -CRIMPED TO STEEL ROD AND HANDHOLE FRAME -EXTENDED 12" OUTSIDE HANDHOLE | ++ |
| ④ | WARNING LABEL AS PER STD. 5-125 (LATEST REVISION) | 1 |

++ - LENGTH TO SUIT

NOTES:

- ALL DIMENSIONS SHOWN ARE FROM TOP OF POLE (EXCEPT AS NOTED) AND MEASURED FROM CENTRE LINE.
- ALL HOLES SHALL BE 3/4" IN DIAMETER.
- IN ALL CASES, IDENTICAL HOLES SHALL BE PLACED 1" BELOW, AND 90° TO DIMENSIONED HOLES.
- RACEWAYS SHALL BE 2" MINIMUM IN DIAMETER AND BE PROVIDED WITH FISH WIRE.
- POLE SHALL BE PRESTRESSED AND BE MADE IN ACCORDANCE WITH CSA STD. A14 (LATEST EDITION).
- THE PURPOSE OF THESE HOLES IS TO PREVENT SLING SLIPPAGE DURING MATERIAL HANDLING.



STREET LIGHTING
50 ft. (15.2 m) Class D
CSA SPUN OCTAGONAL CONCRETE
STREET LIGHTING CLASS POLE

| | | | |
|-----------|-----|------------|-----------------------|
| EFF. DATE | | SCALE | N.T.S. |
| REV. | 001 | 2025 09 13 | STANDARD No. 3100.130 |

METRIC
ALL DIMENSIONS IN MILLIMETRES

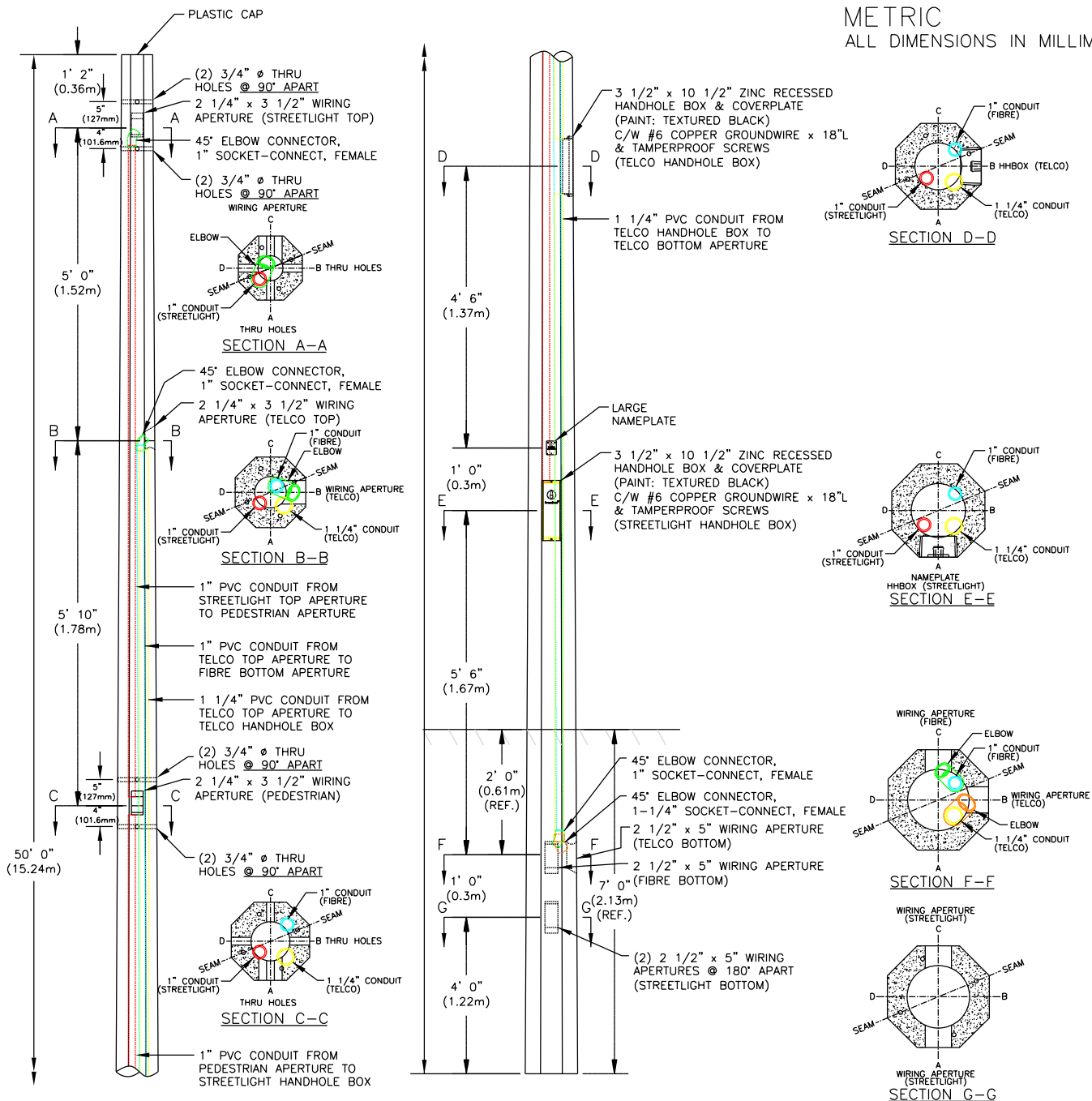

SECTION: OCTAGONAL
 COLOUR: ECLIPSE
 FINISH: POLISHED
 POLE TOP: 6 1/2" (165mm) FL/FL
 POLE BUTT: 12 3/4" (324mm) FL/FL
 POLE HEIGHT: 50' 0" (15.24m)
 APPROX. WGT.: 3,185 lbs. (1445kg)

NOTES:

1. ALL DIMENSIONS SHOWN ARE FROM TOP OF POLE (EXCEPT AS NOTED) AND MEASURED FROM CENTRE LINE.
2. ALL HOLES SHALL BE 3/4" IN DIAMETER.
3. POLE SHALL BE PRESTRESSED AND BE MADE IN ACCORDANCE WITH CSA STD. A14 (LATEST EDITION).



STREET LIGHTING
 BLACK CONCRETE POLISH OCTAGONAL
 50 FT.(15.2M) CSA SPUN CLASS A

| | | | | |
|-----------|-----|------------|-----------------------|--------|
| EFF. DATE | | SCALE | | N.T.S. |
| REV. | 001 | 2025 09 13 | STANDARD No. 3100.135 | |

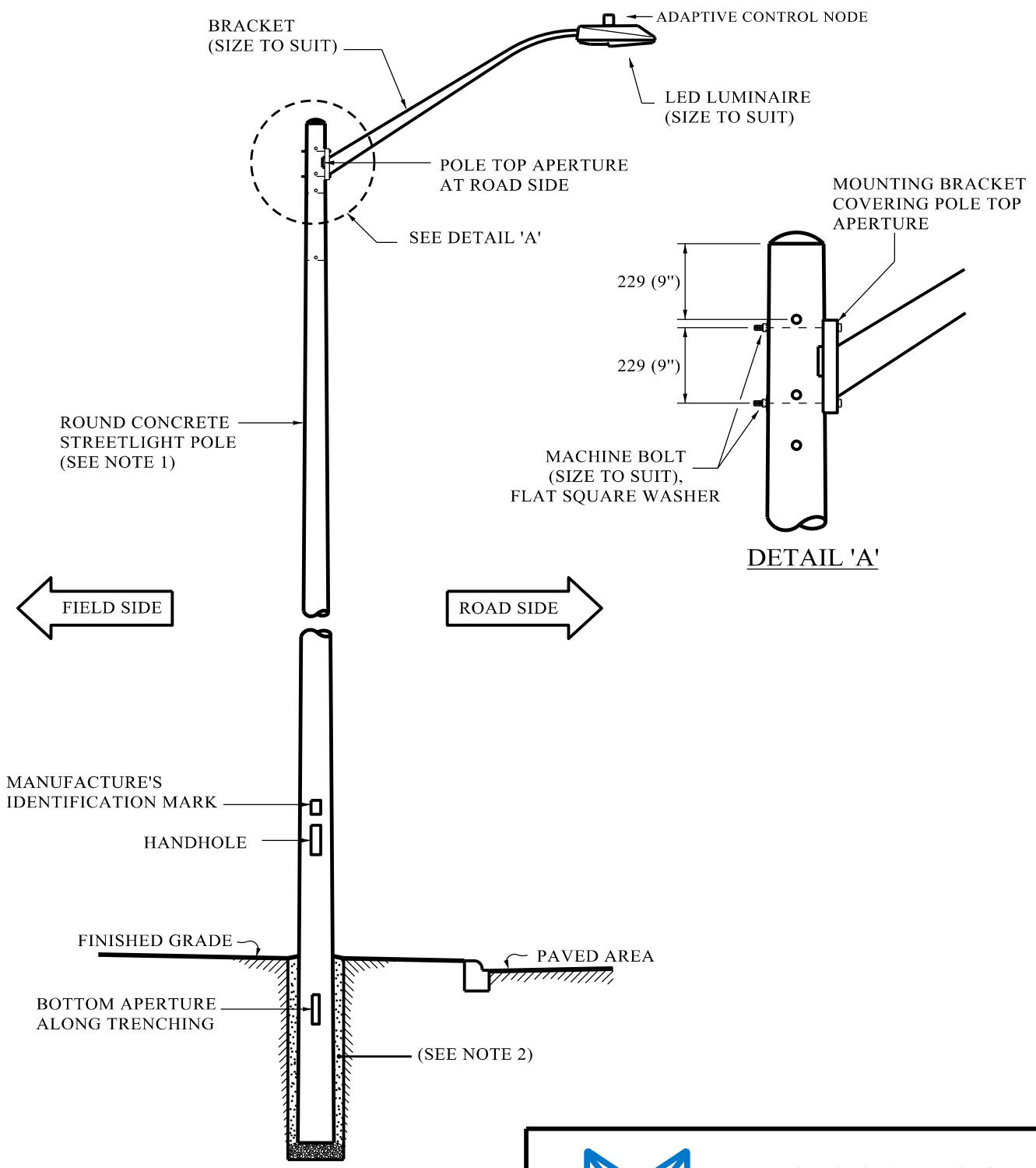

NOTES:

1. REFER TO STD. 3100.080, 3100.085, 3100.090, 3100.095, 3100.100, 3100.105 FOR STREETLIGHT POLE STANDARD DETAILS.
2. REFER TO STD. 3100.230 FOR STREETLIGHT POLE AND BRACKET INSTALLATION REQUIREMENT.



STREET LIGHTING

STREETLIGHT POLE
AND LUMINAIRE ORIENTATION
(CONCRETE POLE)

| | | | |
|-----------|-----|------------|-----------------------|
| EFF. DATE | | SCALE | N.T.S. |
| REV. | 001 | 2025 09 13 | STANDARD No. 3100.150 |

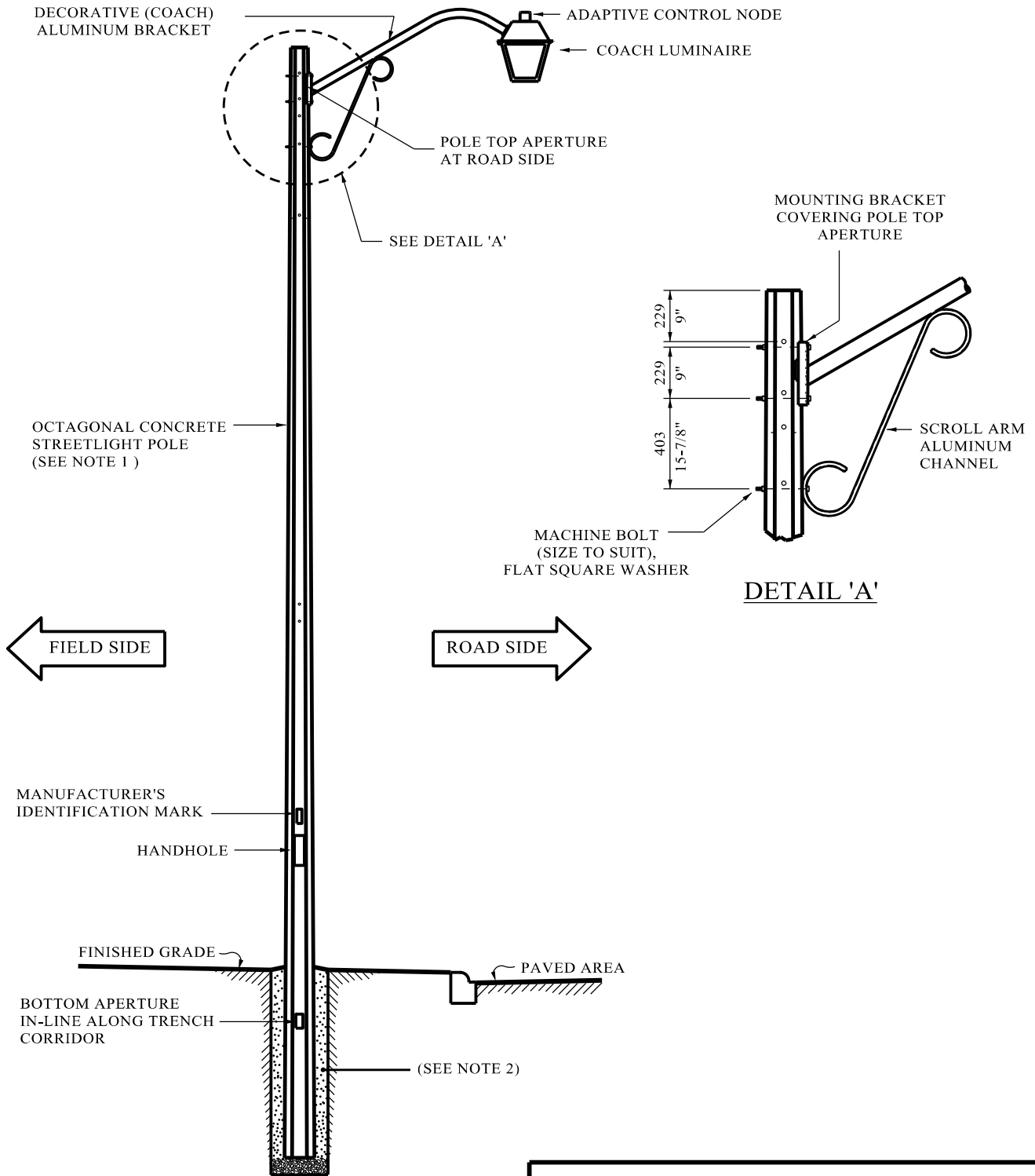

NOTES:

1. REFER TO STD. 3100.110, 3100.115, 3100.120, 3100.125, 3100.130, 3100.135 FOR STREETLIGHT POLE STANDARD DETAILS.
2. REFER TO STD. 3100.230 FOR STREETLIGHT POLE AND BRACKET INSTALLATION REQUIREMENT.



STREET LIGHTING

STREETLIGHT POLE AND LUMINAIRE ORIENTATION (OCTAGONAL BLACK CONCRETE POLE & COACH LUMINAIRE)

EFF. DATE

SCALE

N.T.S.

REV.

001

2025 09 13

STANDARD No. 3100.160

METRIC
ALL DIMENSIONS IN MILLIMETRES

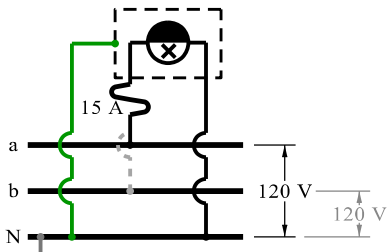

SCHEMATIC 1
120 V (NOTE 4)

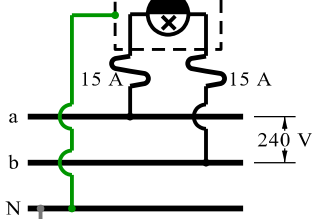

SCHEMATIC 2
240 V (NOTE 4)

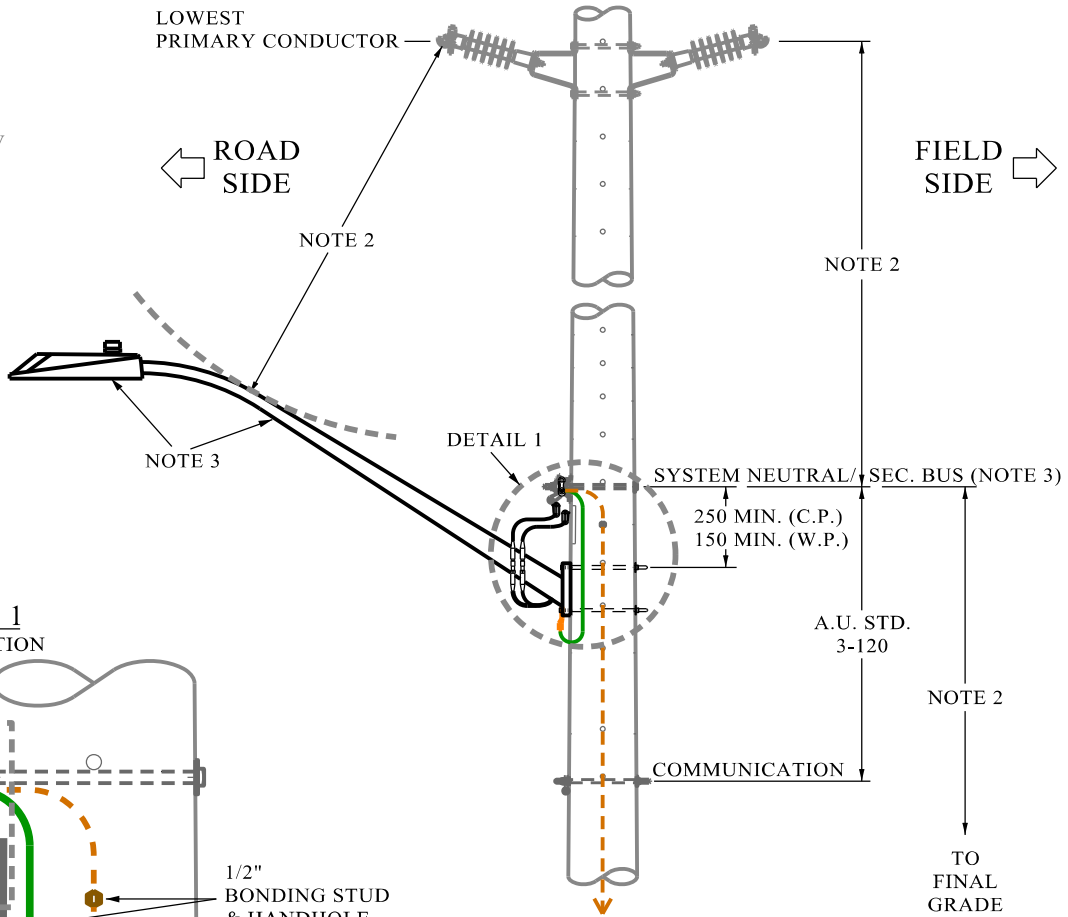

DETAIL 1
S/L CONNECTION

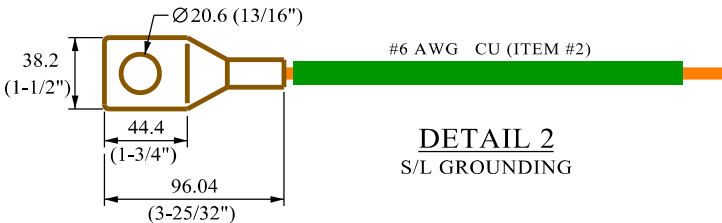
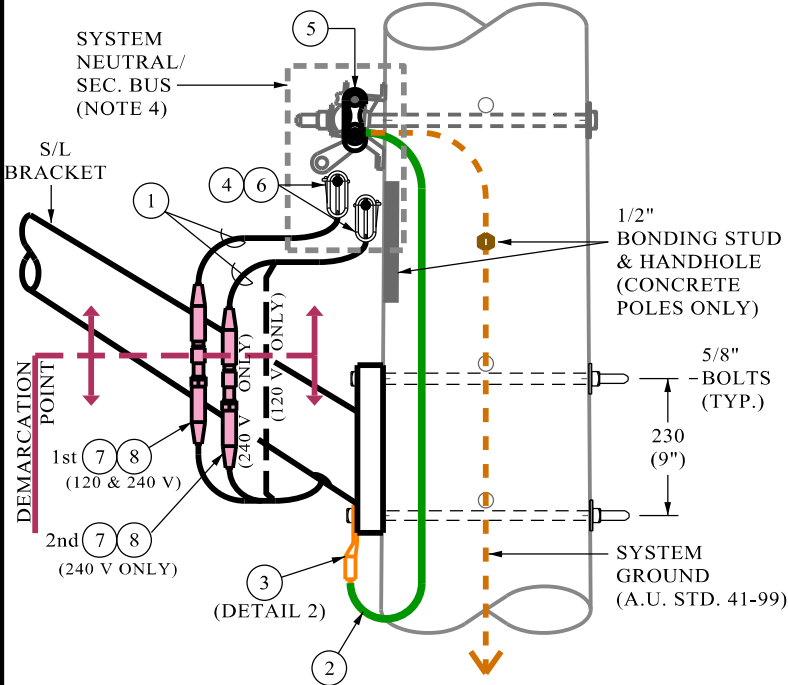

DETAIL 2
S/L GROUNDING

| BILL OF MATERIALS | | | |
|-------------------|--|----------|-------|
| ITEM# | DESCRIPTION | QUANTITY | |
| | | 120 V | 240 V |
| 1 | CABLE , 2C-#14 AWG CU SOLID, PVCJ, 600 V | 4 m | 4 m |
| 2 | CABLE , 1C-#6 AWG CU, GREEN, RWU90, 1000 V | 1 m | 1 m |
| 3 | CONNECTOR, LUG, COMPRESSION, #6 AWG CU | 1 | 1 |
| 4 | CONNECTOR, WEDGE, TAP AL, 250 KCMIL - #14 AWG | 2 | 2 |
| | CONNECTOR, WEDGE, TAP AL, #2AWG - #14 AWG | | |
| 5 | CONNECTOR, WEDGE, TAP AL, 556 KCMIL - #6 AWG | 1 | 1 |
| 6 | COVER | 2 | 2 |
| 7 | FUSE, CARTRIDGE, 15 A | 1 | 2 |
| 8 | FUSE HOLDER, IN-LINE, AL, BRK-AWAY, FOR #6AWG CU | 1 | 2 |

NOTES:

- (A.U.) ALECTRA UTILITIES STD. 3-130 SUPERSEDES THIS STREET LIGHTING STD.
- REFER TO ALECTRA UTILITIES STD. 3-100 FOR STANDARD ATTACHMENT POINTS
- REFER TO S/L DESIGN CONSTRUCTION DRAWINGS FOR LUMINAIRE AND BRACKET SELECTION
- REGARDLESS OF 120 V OR 240 V S/L SUPPLY, THE SECONDARY BUS SHALL CONSISTS OF 3-WIRE, 120/240 V (TO BE SUPPLIED, OWNED & MAINTAINED BY LDC)



STREET LIGHTING
TYPICAL STREETLIGHTING
CONNECTION AT A JOINT-USE
HYDRO DISTRIBUTION POLE

| | | | |
|-----------|-----|------------|-----------------------|
| EFF. DATE | | SCALE | N.T.S. |
| REV. | 001 | 2025 09 13 | STANDARD No. 3100.190 |

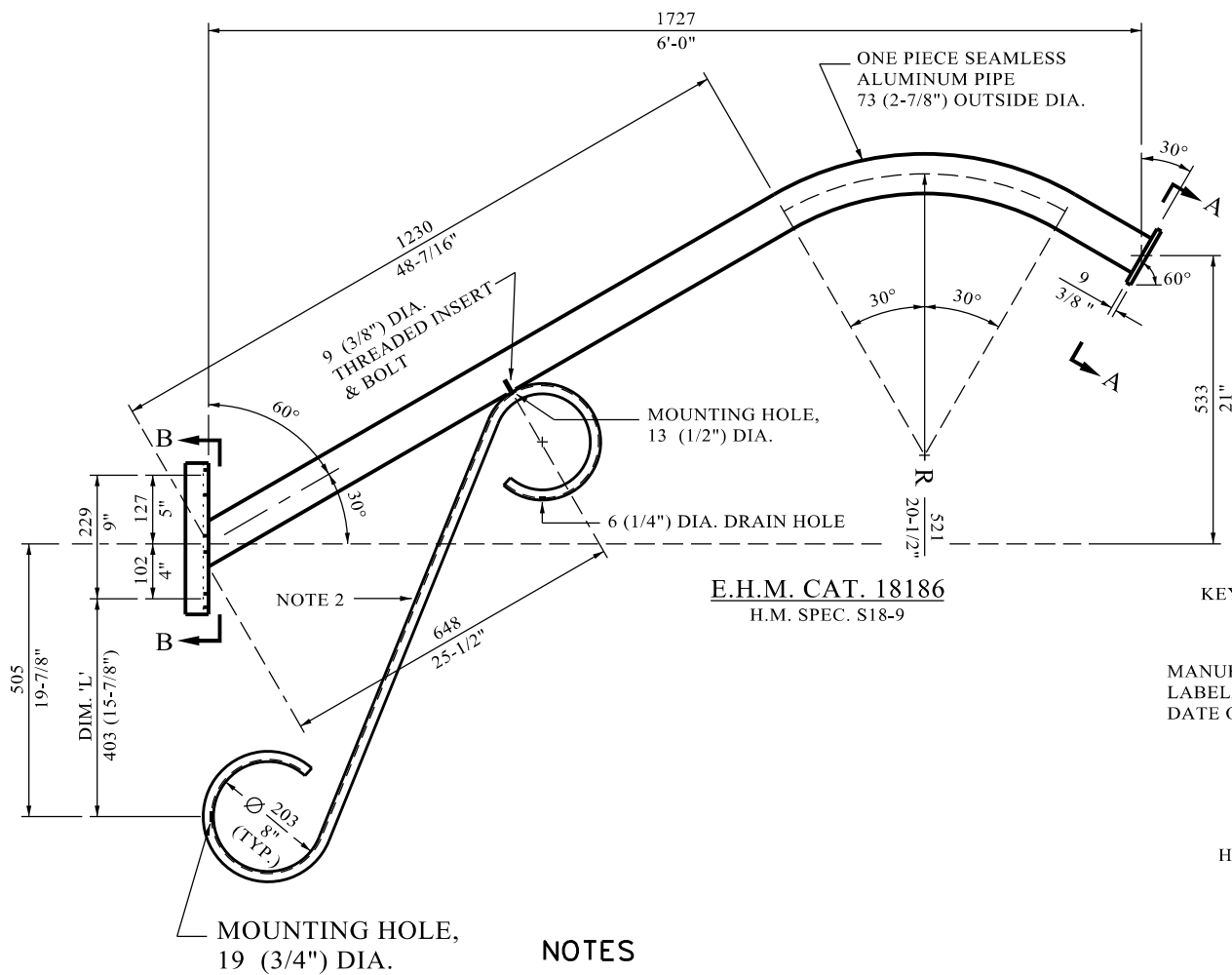

E.H.M. CAT. 18186
H.M. SPEC. S18-9

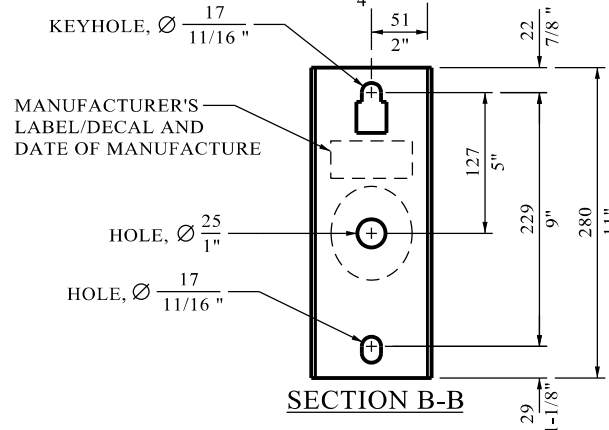
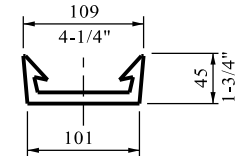
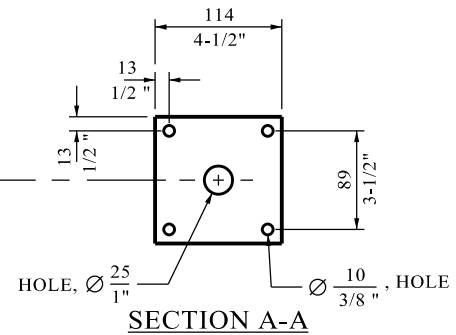

NOTES

1. MATERIALS, STRENGTH AND WELD JOINTS SHALL BE PER APPLICABLE CSA STANDARDS. (WELDED ALUMINUM DESIGN PER CSA S244)
2. SCROLL, ALUMINUM CHANNEL, 38 mm X 19.1 mm X 3.2 mm (1.5" X 3/4" X 1/8") C/W 2-MOUNTING HOLES, APPROXIMATELY 914 mm (36") C TO C OF SCROLL.
3. ALL DIMENSIONS ARE TO THE EXACT SPECIFICATIONS AND DIMENSIONS.
4. DIMENSIONS FOR SECTION A-A, SECTION B-B AND DIMENSION 'L' SHALL BE EXACTLY AS SHOWN.
5. PROPER MOUNTING ANGLE SHOULD BE VERIFIED WITH MANUFACTURER OF THE FIXTURE



STREETLIGHTING
6 ft. VICTORIAN STYLE
ALUMINUM BRACKET

| | | | |
|-----------|-----|------------|-----------------------|
| EFF. DATE | | SCALE | N.T.S. |
| REV. | 001 | 2025 09 13 | STANDARD No. 3100.200 |

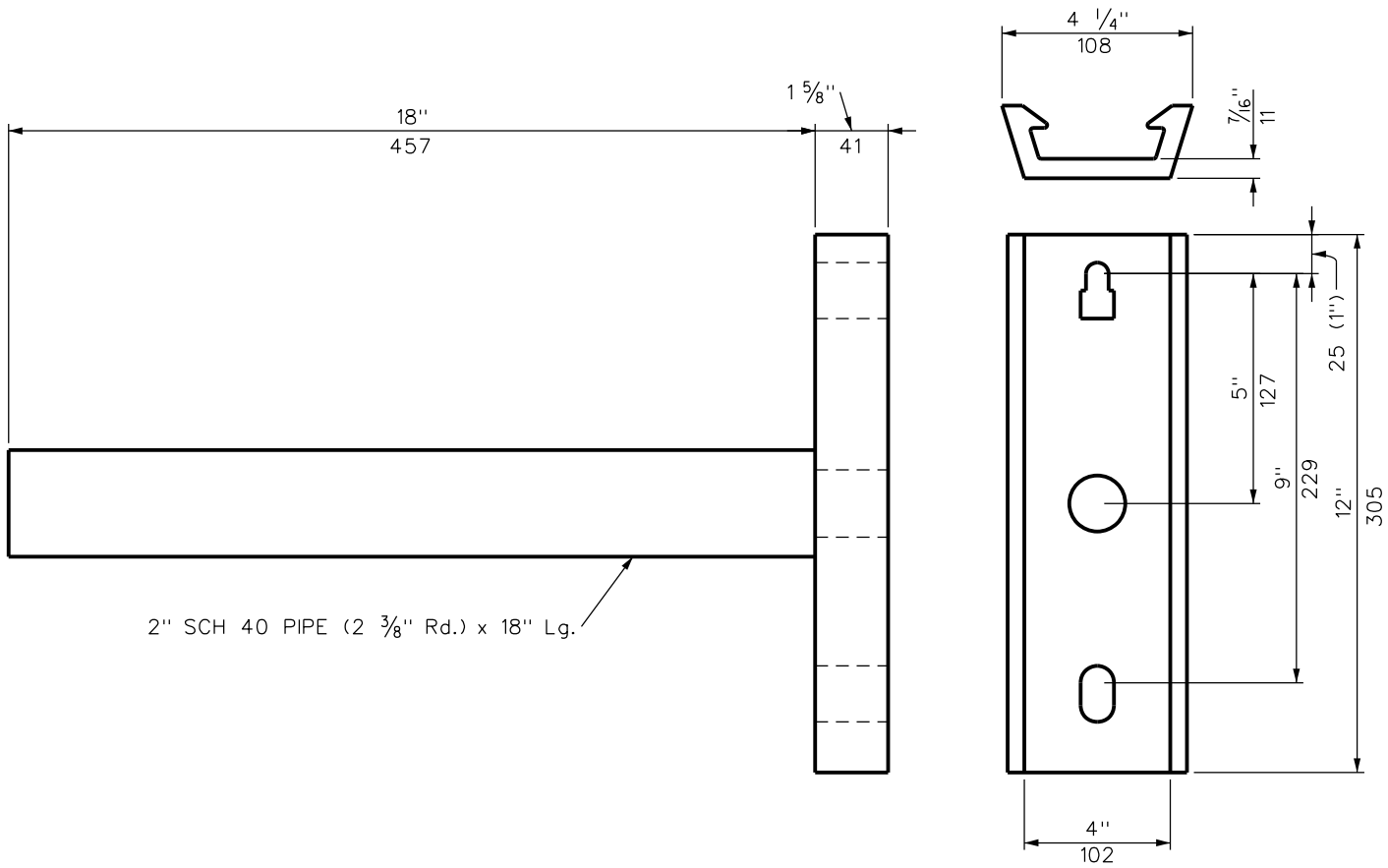

2" SCH 40 PIPE (2 3/8" Rd.) x 18" Lg.

NOTES

1. ALL WELDING AS PER CSA W47.2
2. SURFACE FINISH: BRUSHED ALUMINUM OR POWDER COATED TO MATCH LUMINAIRE
3. MATERIAL 6063-T6 UNLESS NOTED OTHERWISE



STREET LIGHTING

18" PEDESTRAIN BRACKET

| | | | |
|-----------|-----|------------|-----------------------|
| EFF. DATE | | SCALE | N.T.S. |
| REV. | 001 | 2025 09 13 | STANDARD No. 2100.205 |

METRIC
ALL DIMENSIONS IN MILLIMETRES

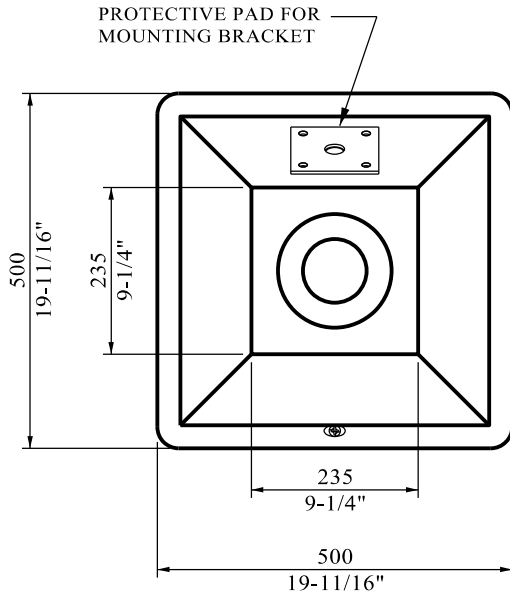

TOP VIEW

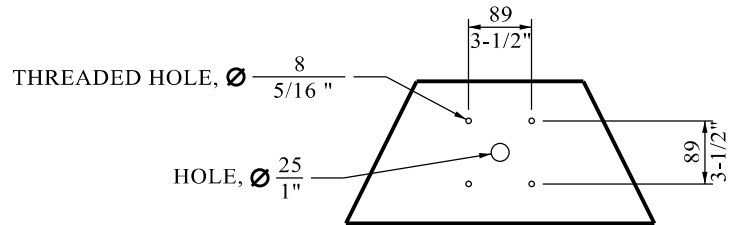
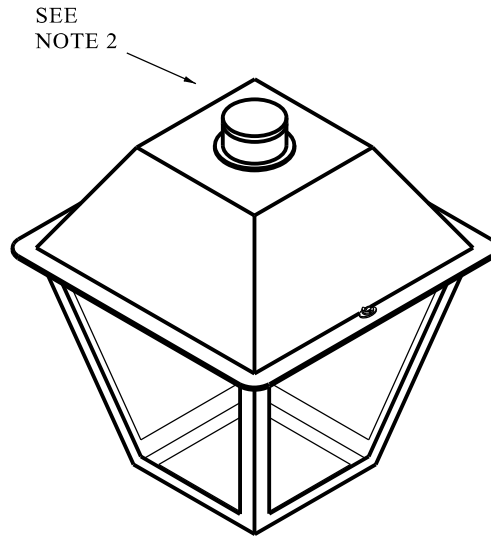

SECTION A-A:
MOUNTING HOLES

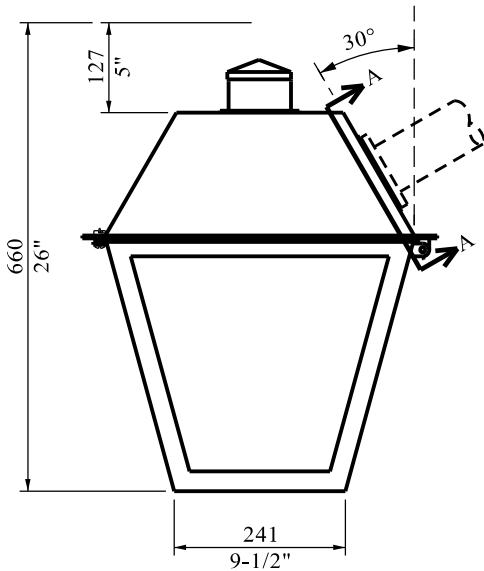

SIDE VIEW

NOTES:

1. MATERIALS AND STRENGTH SHALL BE PER APPLICABLE CSA STANDARD.
2. 7 - PIN N.E.M.A. SOCKET. FOR CoM APPROVED ADAPTIVE CONTROL
3. ALL DIMENSIONS ARE TO THE NEAREST MANUFACTURER'S SPECIFICATIONS AND DIMENSIONS.
4. DIMENSIONS FOR SECTION A-A SHALL BE EXACTLY AS SHOWN.



STREETLIGHTING
TYPICAL BRACKET MOUNTED
COACH LUMINAIRE

| | | | |
|-----------|-----|------------|-----------------------|
| EFF. DATE | | SCALE | N.T.S. |
| REV. | 001 | 2025 09 13 | STANDARD No. 3100.210 |

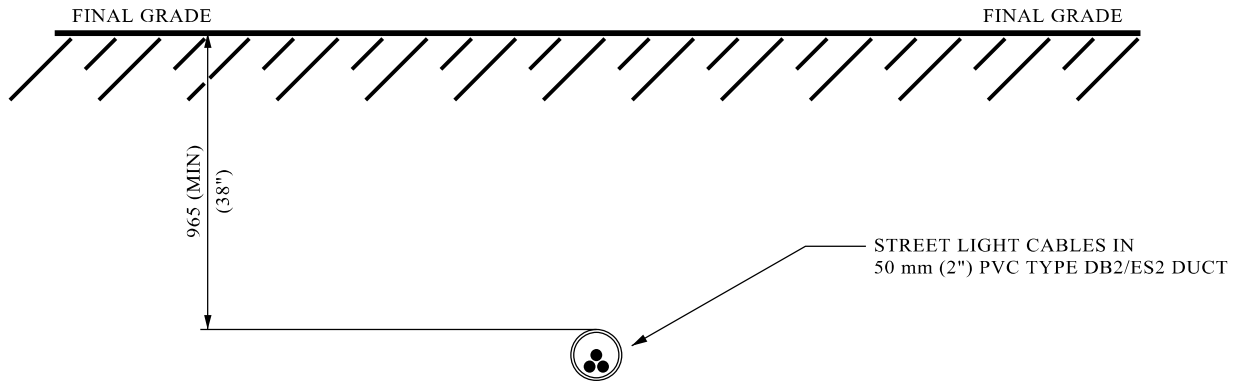

NOTES:

1. ALL STREET LIGHTING INSTALLATIONS ARE OWNED BY THE CITY OF MISSISSAUGA, UNLESS OTHERWISE SPECIFIED.
2. ALL STREETLIGHT DUCT TO BE 50mm (2") PVC AND INSTALLED VIA DIRECTIONAL BORE UNLESS SPECIFIED OTHERWISE.
3. REFER TO T & W STANDARD DRAWINGS - ROADWAY CROSSING, ETC. (2211060-2211157)
4. POLES AND DUCT ROUTE TO MAINTAIN MIN. 0.5m FROM PROPERTY LINES
5. POLES AND DUCT ROUTE TO MAINTAIN MIN. 0.5m FROM SIDEWALKS.
6. POLES AND DUCT ROUTE TO MAINTAIN MIN. 1.0m FROM DRIVEWAYS.
7. POLES TO MAINTAIN MIN. 1.5m FROM THE BACK OF THE CURB & DUCT ROUTE TO MAINTAIN MIN. 0.5m FROM THE BACK OF THE CURB.



**STREET LIGHTING
SEPARATION REQUIREMENTS
FOR STREET LIGHTING ONLY**

| | | | |
|-----------|-----|------------|-----------------------|
| EFF. DATE | | SCALE | N.T.S. |
| REV. | 001 | 2025 09 13 | STANDARD No. 3100.220 |

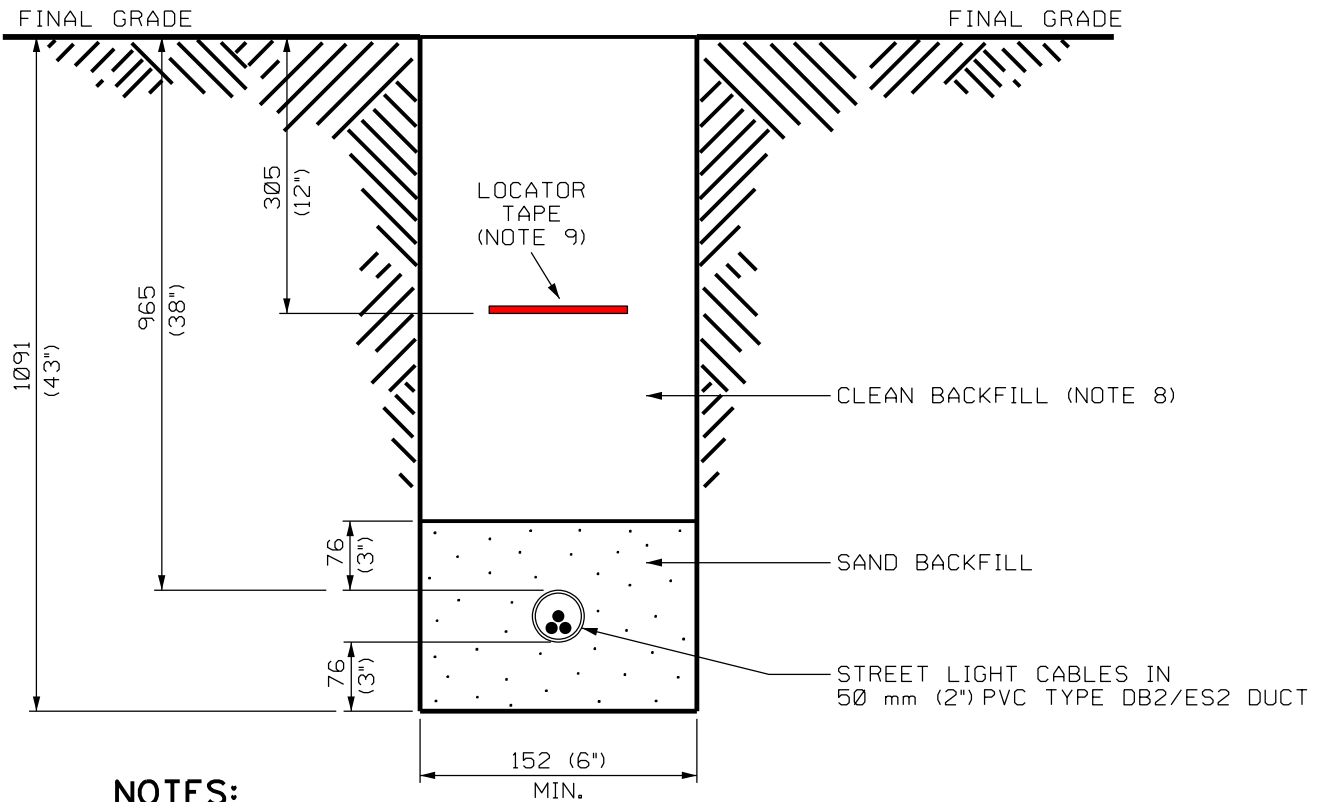

NOTES:

1. ALL STREET LIGHTING INSTALLATIONS ARE OWNED BY THE CITY OF MISSISSAUGA, UNLESS OTHERWISE SPECIFIED.
2. ALL STREETLIGHT DUCT TO BE 50mm (2") PVC AND INSTALLED VIA DIRECTIONAL BORE UNLESS SPECIFIED OTHERWISE.
3. REFER TO T & W STANDARD DRAWINGS - ROADWAY CROSSING, ETC. (2211060-2211157)
4. POLES AND DUCT ROUTE TO MAINTAIN MIN. 0.5m FROM PROPERTY LINES
5. POLES AND DUCT ROUTE TO MAINTAIN MIN. 0.5m FROM SIDEWALKS.
6. POLES AND DUCT ROUTE TO MAINTAIN MIN. 1.0m FROM DRIVEWAYS.
7. POLES TO MAINTAIN MIN. 1.5m FROM THE BACK OF THE CURB & DUCT ROUTE TO MAINTAIN MIN. 0.5m FROM THE BACK OF THE CURB.
8. FOR DRIVEWAYS, BACKFILL SHALL BE GRANULAR "A".
9. LOCATOR TAPE SHALL BE A RED PLASTIC, 152 mm (6") WIDE x 0.1 mm (0.004") THICK C/W BLACK BOLD LETTERING "CAUTION BURIED ELECTRIC LINE BELOW"



**STREET LIGHTING
SEPARATION AND TRENCH
REQUIREMENTS
FOR STREET LIGHTING ONLY**

| | | | |
|-----------|-----|------------|-----------------------|
| EFF. DATE | | SCALE | N.T.S. |
| REV. | 001 | 2025 09 13 | STANDARD No. 3100.225 |

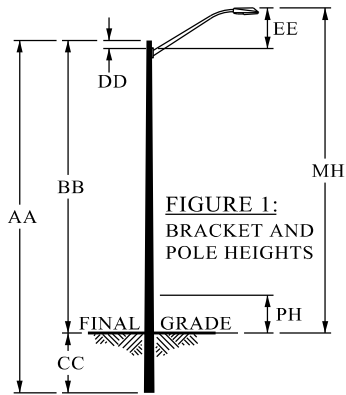

**FIGURE 1:
BRACKET AND
POLE HEIGHTS**

| | | | | | |
|----------------------------------|------|---------------|---------------|----------------|----------------|
| CONCRETE POLE HEIGHT* | [AA] | 6.1 m (20') | 9.9 m (32.5') | 12.2 m (40') | 15.2 m (50') |
| POLE HEIGHT ABOVE GRADE | [BB] | 4.5 m (15') | 8.2 m (27') | 10.4 m (34') | 13.1 m (43') |
| BURIAL DEPTH | [CC] | 1.5 m (5') | 1.7 m (5.5') | 1.8 m (6') | 2.1 m (7') |
| BRACKET ATTACHMENT FROM POLE TOP | [DD] | 0.2 m (9") | 0.2 m (9") | 0.2 m (9") | 0.2 m (9") |
| BRACKET UP-LIFT (2.4 m/8' BRKT) | [EE] | N/A | 1.2 m (4') | 1.2 m (4') | 1.2 m (4') |
| POLE HAND HOLE | [PH] | 1.1 m (3.5') | 1.1 m (3.5') | 1.1 m (3.5') | 1.1 m (3.5') |
| MOUNTING HEIGHT | [MH] | 4.2 m (13.8') | 9.2 m (30.2') | 11.4 m (37.2') | 14.1 m (46.3') |

* - REF. STD. 3100.070, 3100.080, 3100.085, 3100.090, 3100.095, 3100.100 AND 3100.115 (FOR ROUND CONCRETE POLE)
REF. STD. 3100.110, 3100.115, 3100.120, 3100.125, 3100.130 AND 3100.135 (FOR OCTAGONAL BLACK CONCRETE POLE)

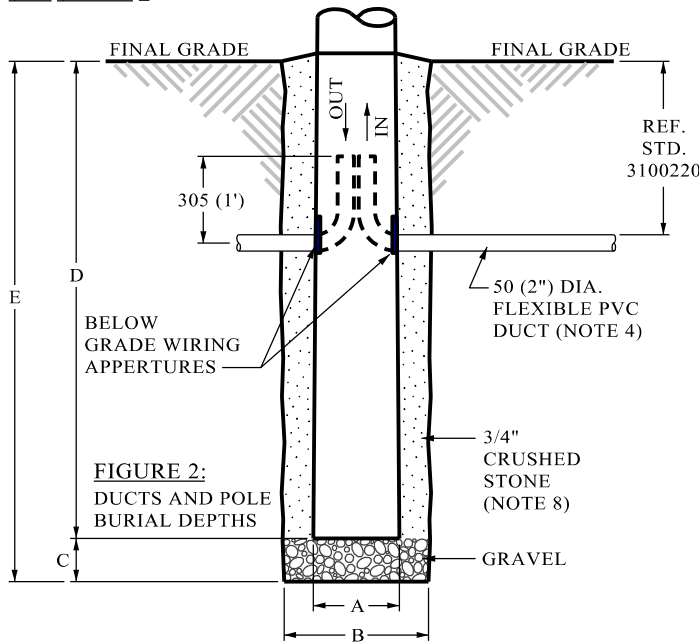

**FIGURE 2:
DUCTS AND POLE
BURIAL DEPTHS**

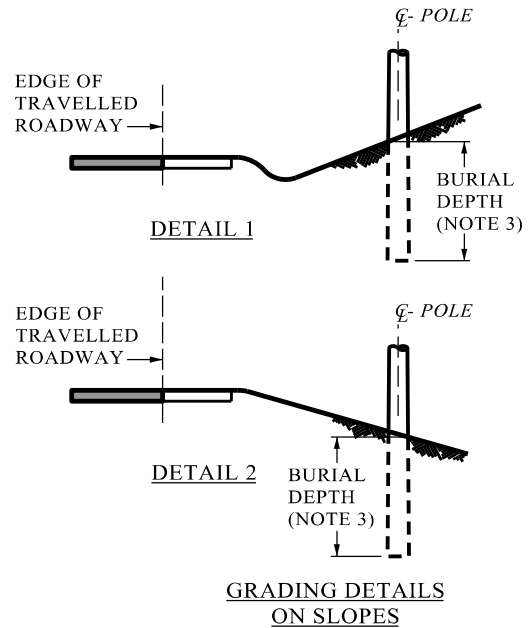

**GRADING DETAILS
ON SLOPES**

| POLE HEIGHT | DIMENSIONS | | | | |
|---------------|-------------------------|---------------------|-------------|--------------|--------------|
| | A | B* | C | D | E |
| 6.1 m (20') | 213 mm (8.4") DIA. +/- | 416 mm (16.4") DIA. | 152 mm (6") | 1.5 m (5.0') | 1.7 m (5.5') |
| 9.9 m (32.5') | 305 mm (12") DIA. +/- | 508 mm (20") DIA. | 152 mm (6") | 1.7 m (5.5') | 1.8 m (6.0') |
| 12.2 m (40') | 330 mm (13") DIA. +/- | 508 mm (20") DIA. | 152 mm (6") | 1.8 m (6.0') | 2.0 m (6.5') |
| 15.2 m (50') | 394 mm (15.5") DIA. +/- | 660 mm (26") DIA. | 203 mm (8") | 2.1 m (7.0') | 2.3 m (7.7') |

NOTES:

1. ALL STREETLIGHT INSTALLATIONS ARE OWNED BY THE CITY OF MISSISSAUGA, UNLESS OTHERWISE SPECIFIED.
2. SUBJECT TO SOIL CONDITION, ONLY THE INSPECTOR MAY DEVIATE FROM THE ABOVE REQUIREMENTS.
3. BURIAL DEPTH SHALL BE MEASURED FROM THE LOWEST GRADE ELEVATION AT POLE.
4. FOR CABLES TO BE ROUTED IN AND OUT OF THE POLE, TWO (2) OF 50 mm (2") DIA. FLEXIBLE PVC DUCTS SHALL BE INSERTED AS SHOWN IN FIGURE 2. THE OTHER ENDS SHALL BE COUPLED AND SECURED BACK INTO THE MAIN 50 mm (2") DIA. PVC DB2/ES2 DUCTS (NOT SHOWN).
5. BACKFILL WITH 3/4" CRUSHED STONE COMPACTED IN LAYERS OF 250 mm (10") WITH MECHANICAL FOOT TAMPER.
6. ALL POLE HOLES SHALL BE EXCAVATED BY APPROPRIATE SIZE OF AUGER.
7. POLE MUST NOT SLANT TOWARDS ROAD SIDE.
2% DEFLECTION FROM VERTICAL TO FIELD SIDES IS WITHIN TOLERANCE.
8. TOP 6" TO BE RESTORED WITH TOP SOIL AFTER BACK FILL HAS SETTLED, AS PER CITY STANDARD AND SOD CUT IN AROUND DISTURBED LOCATION.



**STREETLIGHT POLES
DIRECT BURIED
INSTALLATION REQUIREMENTS
(CONCRETE POLE)**

| | | | |
|-----------|-----|------------|-----------------------|
| EFF. DATE | | SCALE | N.T.S. |
| REV. | 001 | 2025 09 13 | STANDARD No. 3100.230 |

| Luminaire Type | Model | Supplier |
|-----------------------|-------------------------------|-----------------|
| Underpass | W4GLED_20C1000_40K_T3S | Halophane |
| Roadway | CNX-LRL5-2M-40-070 | Conxcorp |
| Roadway | CNX-LRL5-2M-40-120 | Conxcorp |
| Roadway | CNX-LRL5-3M-40-120 | Conxcorp |
| Roadway | CNX-LRL5-3M-40-150 | Conxcorp |
| Roadway | CNX-LRL5-3M-40-200 | Conxcorp |
| Pathway | CNX-LRL5-2M-40-030 | Conxcorp |
| Decorative | LPT-2M-060-Bracket Side Mount | Conxcorp |

Appendix 3: City of Mississauga Street Classification System

NOTE: The attached map is Schedule 3 of Draft Mississauga Official Plan 2051. Once the Draft Plan is adopted, please refer to the Mississauga Official Plan Schedule 3 for current Street Classification.

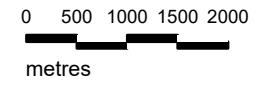
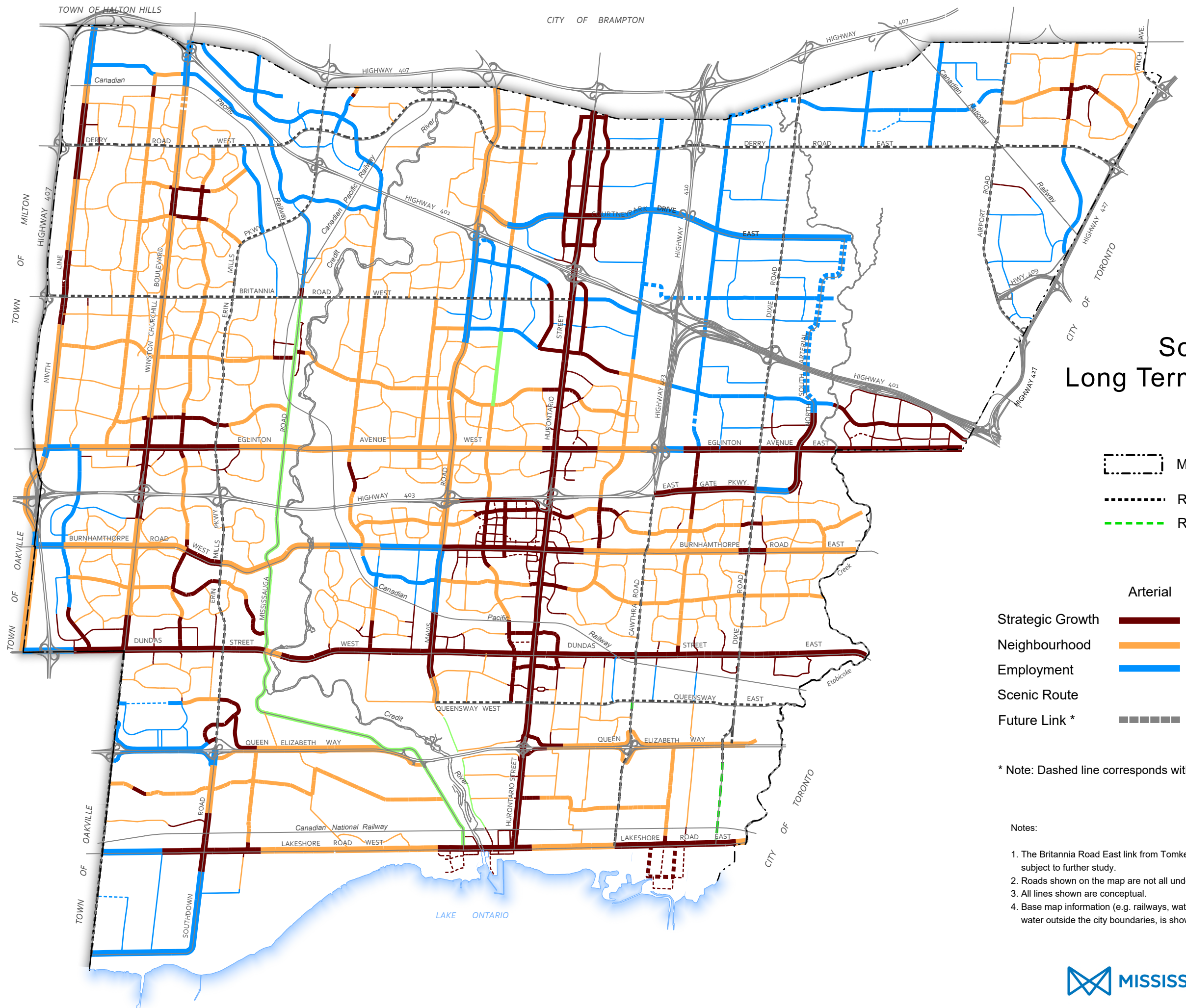

DRAFT

Schedule 3 Long Term Street Network

- Municipal Boundary
- Region of Peel Arterial
- Region of Peel Scenic Route

| | Arterial | Major Collector | Minor Collector |
|------------------|----------|-----------------|-----------------|
| Strategic Growth | | | |
| Neighbourhood | | | |
| Employment | | | |
| Scenic Route | | | |
| Future Link * | | | |

* Note: Dashed line corresponds with the above location colours and type widths.

Notes:

1. The Britannia Road East link from Tomken Road to Kennedy Road is conceptual and is subject to further study.
2. Roads shown on the map are not all under Mississauga jurisdiction.
3. All lines shown are conceptual.
4. Base map information (e.g. railways, watercourses), including any lands or bodies of water outside the city boundaries, is shown for information purposes only.