

1315 BOUGH BEECHES BOULEVARD

MISSISSAUGA, ON L4W 4A1

Project Number
25-141

Client

1315 BOUGH BEACHES LTD
2700 DUFFERIN ST., UNIT 50
TORONTO, ON M6B 4J3

Consultant

ARCADIS
55 ST. CLAIR AVENUE WEST
TORONTO, ON M4V 2Y7
TEL: 416 596 1930

FABIAN PAPA & PARTNERS
3901 HIGHWAY 7, SUITE 500
VAUGHAN, ON L4L 8L5
TEL: 905.264.2420

WIND ASSOCIATES LTD.
47 ROSELAWN AVENUE
TORONTO, ON M4R 1E5
TEL: 416.968.3511

Revisions

| | | | |
|---|---------------------------------|------------|-----|
| 1 | ISSUED FOR OPA ZBA SUBMISSION 1 | 2026-03-13 | LTC |
| # | ISSUED FOR XXX | YYYY-MM-DD | BY |

Stamp

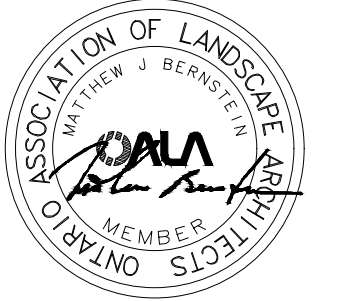

Key map



Scale

0
AS INDICATED

Phase

OPA / ZBA PHASE

North

Drawing Name

LANDSCAPE DETAILS (GF SITE FURNITURE)

Sheet Number

NOT FOR CONSTRUCTION

LD.221

URBAN bicycle post
586-901A
Designed by Artur Wozniak, Hallvard Jakobsen

Urban bicycle post provides good support for two bicycles. The solid steel hoops ensure secure locking.

Primary material
Hot-dip galvanized steel
All cast components are hot-dip galvanized, which produces a rust-free surface after 4 weeks. We offer a lifetime anti-rust warranty. Contact us via CS.M

Sustainability
Indicators: Global warming potential, Acid equivalent, Recycled content, Recycled material, Use, Carbon to GWP 100, H120, H120, H120, H120

Certifications
Intertek

Warranty
+ Lifetime warranty against rust
+ 10 year warranty on powder coating
+ 10 year warranty on steel
+ Spare parts always available

Visit www.vestre.com for more information. Specifications are subject to change without notice. ©2025 Vestre Inc.

4 BIKE RACK OR APPROVED EQUAL
N.T.S.

PIXEL

SHORT - IPE - BACKLESS

TALL - IPE - BACKLESS

PIXEL is a modular seating system consisting of square and rectangular tables and chairs. The tables are made of high-quality IPE wood and are available in different sizes and finishes. The chairs are made of high-quality aluminum and are available in different finishes. The system is easy to assemble and disassemble, making it ideal for outdoor use.

Primary material
Hot-dip galvanized and powder-coated steel

Color
RAL 1013 - Delta yellow
Powder coated with 150µm film for standard colors. Vestre offers more than 200 standard RAL classic colors at no extra charge.

Sustainability
Indicators: Global warming potential, Acid equivalent, Recycled content, Recycled material, Use, Carbon to GWP 100, H120, H120, H120, H120

Certifications
Intertek

Warranty
+ Lifetime warranty against rust
+ 10 year warranty on powder coating
+ 10 year warranty on steel
+ Spare parts always available

Visit www.vestre.com for more information. Specifications are subject to change without notice. ©2025 Vestre Inc.

3 SEATING TERRACE MODULES OR APPROVED EQUAL
N.T.S.

APRIL round table
732-900A
Designed by Tore Bergersen, Michael Olofsson, Espen Voll

April round table comes in different models and sizes. The round and square tables go particularly well with chairs, while the rectangular tables are ideal for benches with or without a backrest. The APRIL table is ADA-compliant.

Primary material
Hot-dip galvanized and powder-coated steel

Color
RAL 1013 - Delta yellow
Powder coated with 150µm film for standard colors. Vestre offers more than 200 standard RAL classic colors at no extra charge.

Sustainability
Indicators: Global warming potential, Acid equivalent, Recycled content, Recycled material, Use, Carbon to GWP 100, H120, H120, H120, H120

Certifications
Intertek

Warranty
+ Lifetime warranty against rust
+ 10 year warranty on powder coating
+ 10 year warranty on steel
+ Spare parts always available

Visit www.vestre.com for more information. Specifications are subject to change without notice. ©2025 Vestre Inc.

2 SMALL TABLE OR APPROVED EQUAL
N.T.S.

APRIL chair
76-900A
Designed by Espen Voll, Michael Olofsson, Tore Bergersen

April chair available in fixed or swivel version, with or without armrests.

Primary material
Hot-dip galvanized and powder-coated steel

Color
RAL 1013 - Delta yellow
Powder coated with 150µm film for standard colors. Vestre offers more than 200 standard RAL classic colors at no extra charge.

Secondary material
Lined with proofed Nordic pine (standard wood) (see 800/900)
Standard wood with a 15 year anti-rust warranty. High-quality FSC-certified timber. Hardwax 17 on the Birnall scale for outdoor use.

Sustainability
Indicators: Global warming potential, Acid equivalent, Recycled content, Recycled material, Use, Carbon to GWP 100, H120, H120, H120, H120

Certifications
Intertek

Warranty
+ Lifetime warranty against rust
+ 10 year warranty on powder coating
+ 10 year warranty on wood
+ Spare parts always available

Visit www.vestre.com for more information. Specifications are subject to change without notice. ©2025 Vestre Inc.

1 CHAIR OR APPROVED EQUAL
N.T.S.

Andreas Sofa
HS6632K-SBPG

This product is Made to Order just for you and will take approximately 2 weeks to complete.

The Andreas lounge collection combines elements taken from Danish design and mid-century modern interior furniture for an elevated contemporary outdoor look. This sofa is crafted in Canada from a fully welded, powder-coated aluminum frame with Sunbrella solution-dyed acrylic UV resistant cushions. Made in Canada

Add your matching protective cover: [HSPF1311](#)

PRODUCT SPECS

| | |
|--------------------|---|
| Arm Height | 22" |
| General Dimensions | 83" W X 35" D X 28" H |
| Seat Depth | 21" |
| Seat Height | 17" |
| Weight | 75lb |
| Fabric | 100% Sunbrella Acrylic - Durable, UV-Resistant And Water-Repellent Fabric |
| Frame | Powder-Coated Aluminum |
| Country Of Origin | Canada |
| Style | Contemporary |

info@hauserstores.com
800-268-7328 ext. 232
hauserstores.com

8 SOFA OR APPROVED EQUAL
N.T.S.

Andreas Lounge Chair
HS6630K-SBPG

This product is Made to Order just for you and will take approximately 2 weeks to complete.

The Andreas lounge collection combines elements taken from Danish design and mid-century modern interior furniture for an elevated contemporary outdoor look. This lounge chair is crafted in Canada from a fully welded, powder-coated aluminum frame with Sunbrella solution-dyed acrylic UV resistant cushions. Made in Canada

Add your matching protective cover: [HSPF1309](#) or [HSTG741](#)

PRODUCT SPECS

| | |
|--------------------|---|
| Arm Height | 22" |
| General Dimensions | 34" W X 35" D X 28" H |
| Seat Depth | 21" |
| Seat Height | 17" |
| Weight | 45lb |
| Fabric | 100% Sunbrella Acrylic - Durable, UV-Resistant And Water-Repellent Fabric |
| Frame | Powder-Coated Aluminum |
| Country Of Origin | Canada |
| Style | Contemporary |

info@hauserstores.com
800-268-7328 ext. 232
hauserstores.com

7 LOUNGE CHAIR OR APPROVED EQUAL
N.T.S.

48" Rectangular Firepit
CHSDK003

Our Dekko Rectangular Firepit embodies the highest level of quality, design and Canadian craftsmanship. The proprietary material is less than half the weight of regular concrete. Strength and durability are uncompromised, creating a product that is weather resistant, and able to take extreme heat and cold, all while achieving a striking resemblance of real stone. Includes weather cover, protective glass surround and is available with either Propane or Natural Gas connections. Standard Manual Ignition. Electric Start Ignition available as a premium (overall height increases to 10" with this option). Weight listed below does not include decorative rock or protective glass surround.

CSA / UL Approved

Width: 48" (121.9 cm)
Depth: 20" (50.8 cm)
Height: 15" (38.1 cm)
Weight: 145.0 lb (65.8 kg)

sales@hauserstore.com | 1-800-268-7328 | hauserstore.com

6 FIRE FEATURE WITH GUARD OR APPROVED EQUAL
N.T.S.

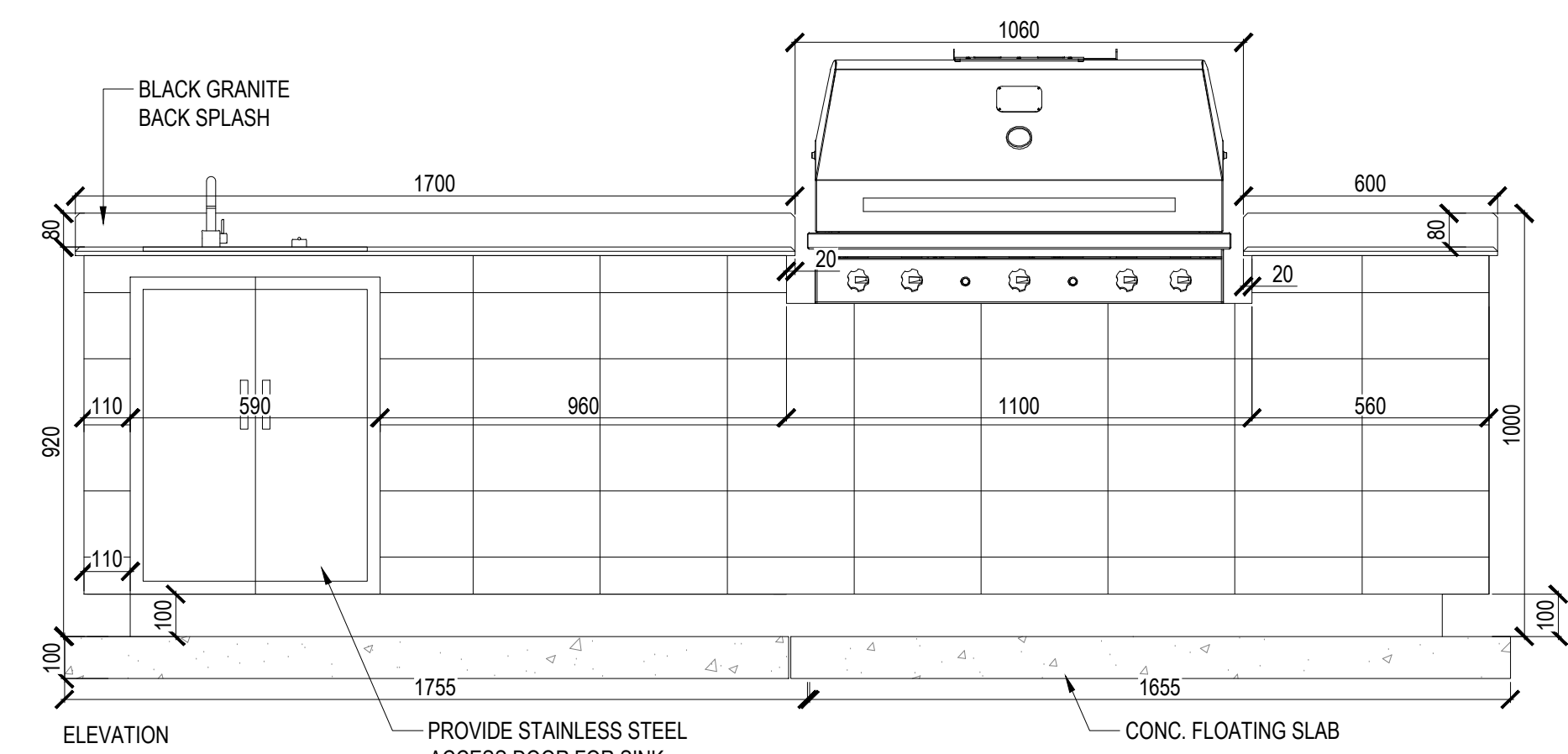

5 OUTDOOR KITCHEN OR APPROVED EQUAL
SCALE 1:15