

**2233-2235  
HURONTARIO ST**  
MISSISSAUGA, ON

Project Number  
**26-107**

Client  
**2233 & 2235 Hurontario LTD.**

Consultant

ARCHITECT  
BOP QUADRANGLE  
8 SPADINA AVENUE, SUITE 2100  
TORONTO, ON M5V 0S8  
TEL: 416-598-1240

CIVIL ENGINEER  
URBANTECH  
2030 BRISTOL CIRCLE, SUITE 105  
OKAVILLE, ON L6H 0H2  
TEL: 905-829-8818

Revisions

1	ISSUED FOR ZBA	2026-04-13	KA
#	ISSUED FOR XXX	YYYY-MM-DD	BY

Stamp



Key map

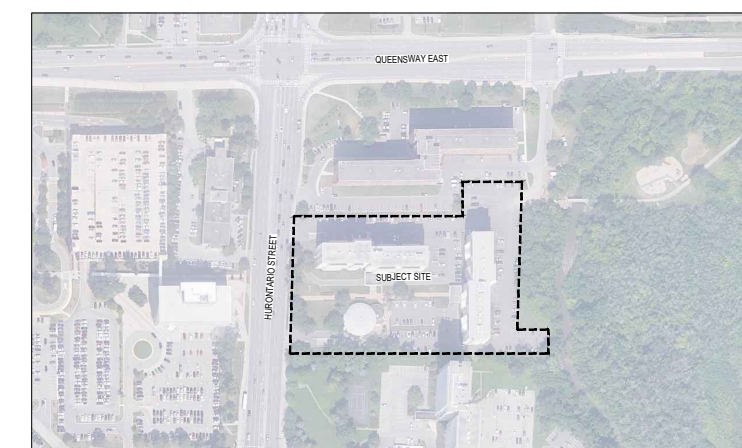

Scale  
AS SHOWN

Phase  
ZBA North

Drawing Name  
LANDSCAPE DETAILS

Sheet Number  
NOT FOR CONSTRUCTION

**LD.202**

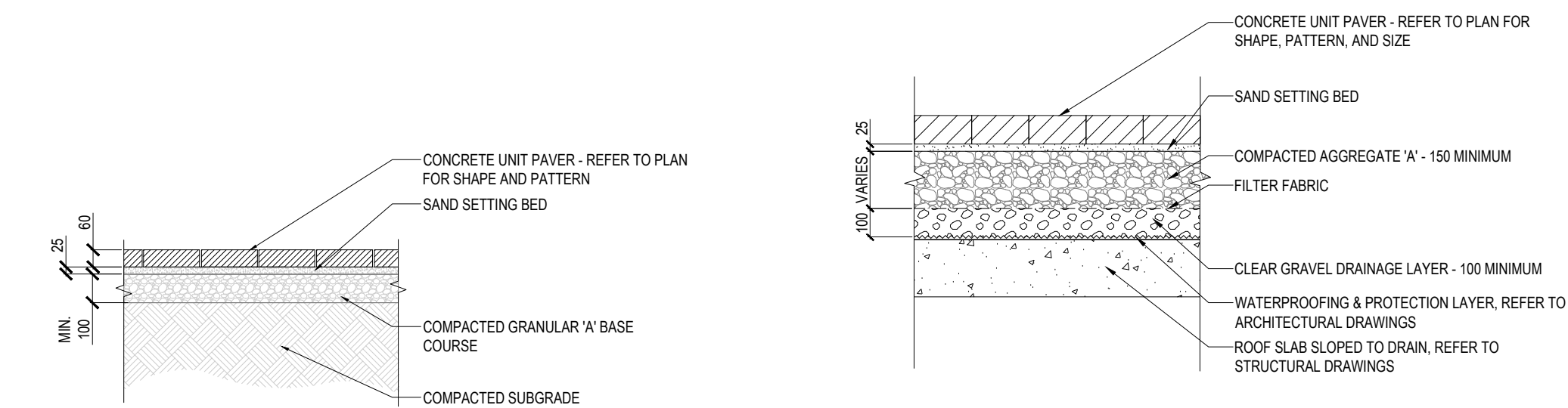

**1 ON GRADE UNIT PAVER**  
SCALE=1:20

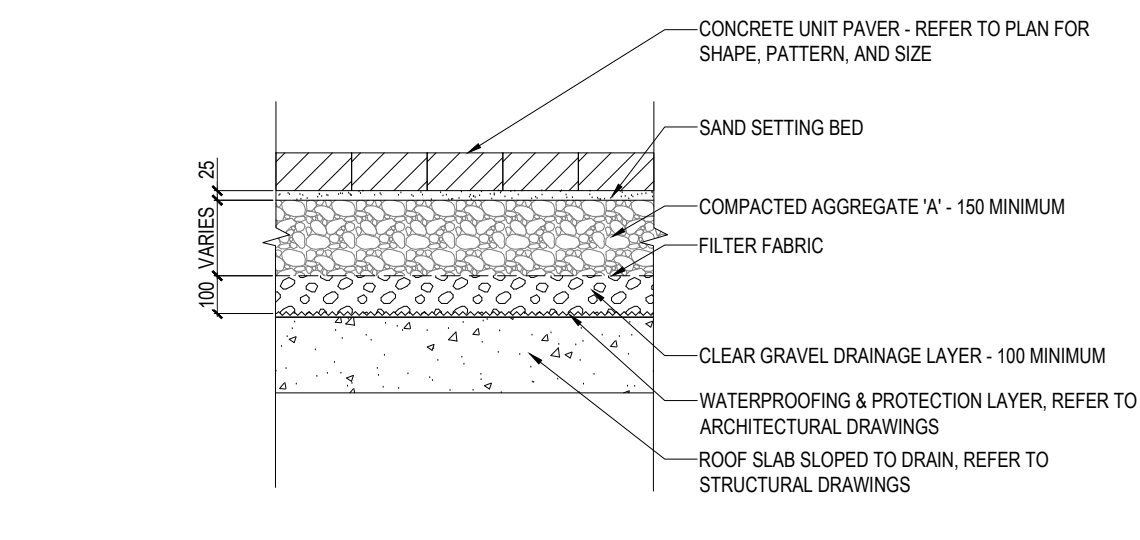

**2 PEDESTRIAN UNIT PAVERS ON ROOF SLAB**  
1:20

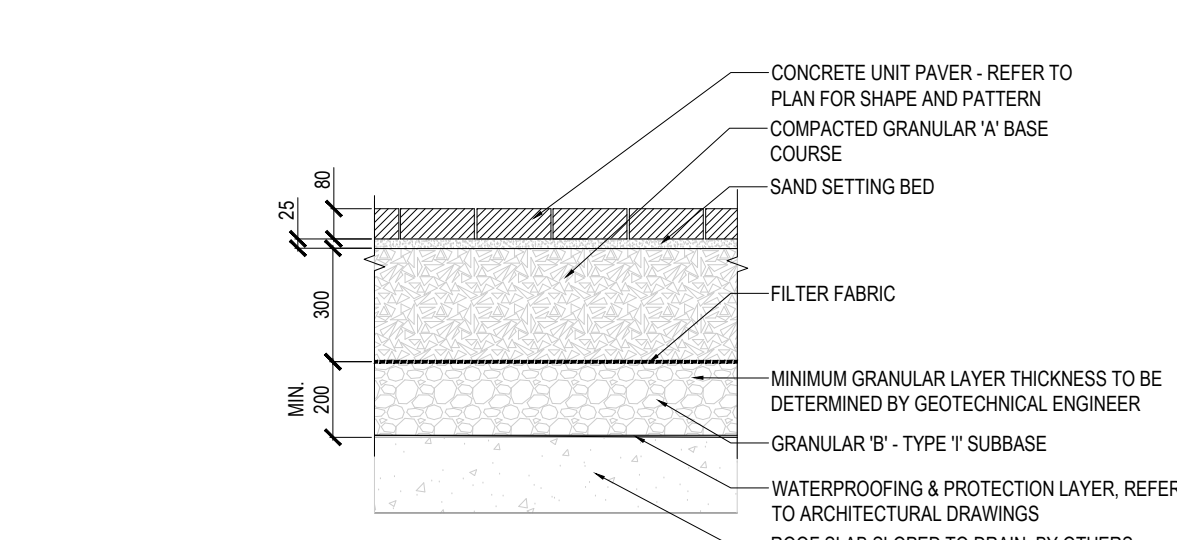

**3 HEAVY DUTY UNIT PAVER ON SLAB**  
SCALE=1:20

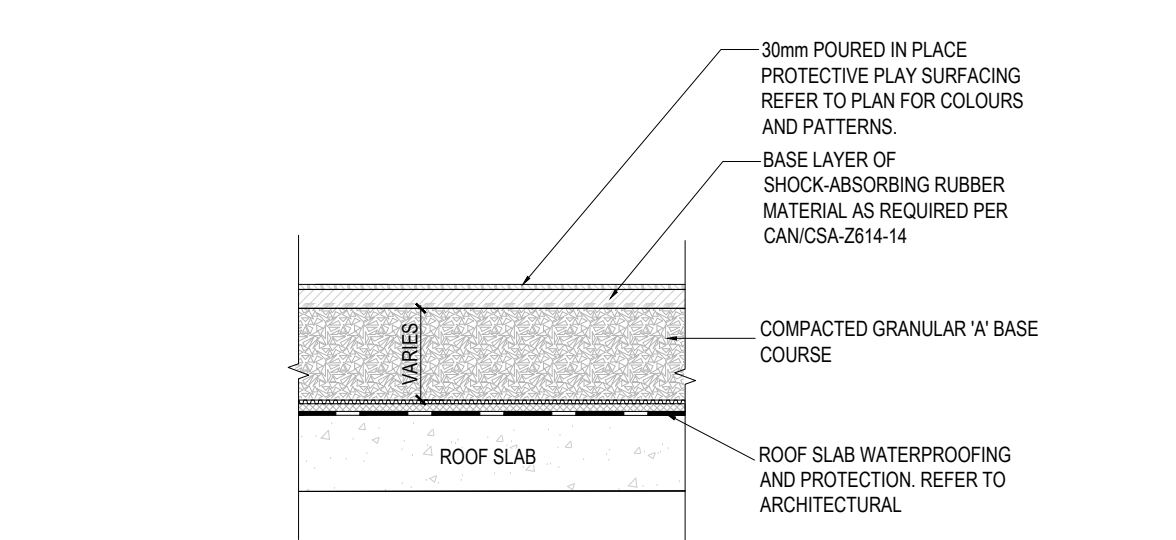

**4 PROTECTIVE PLAY SURFACE**  
1:20

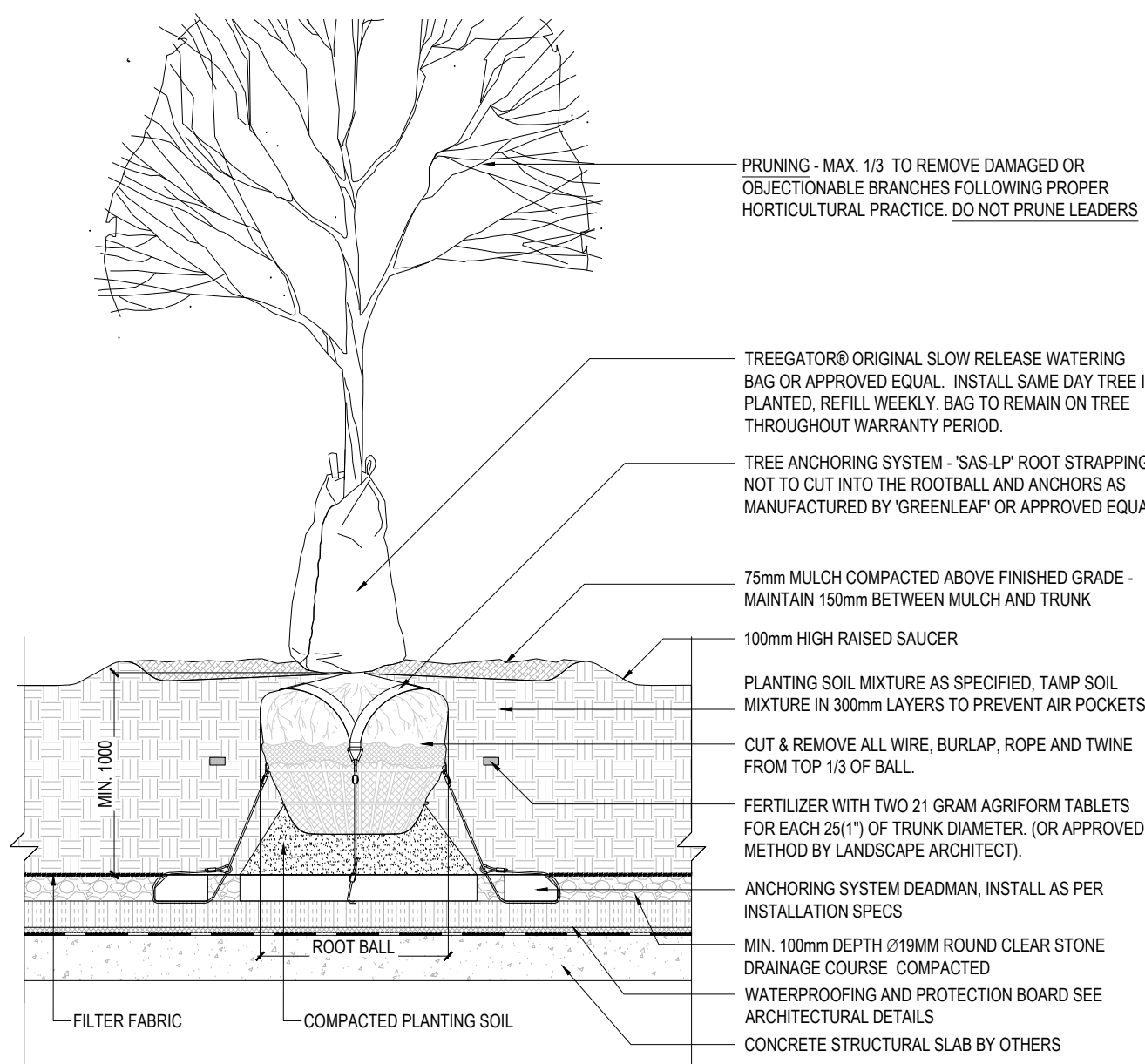

**5 DECIDUOUS TREE PLANTING ON SLAB**  
1:25

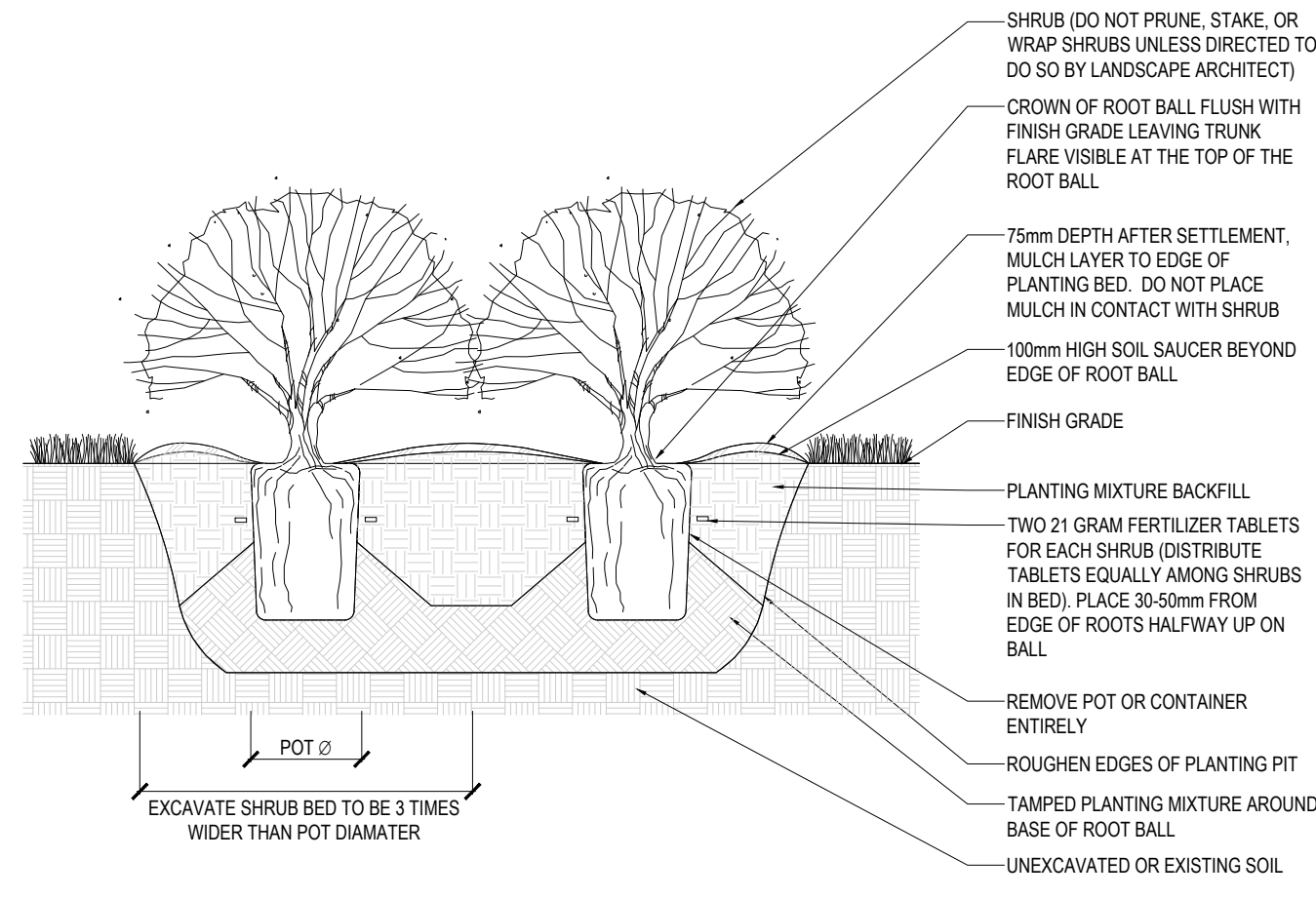

**6 POTTED SHRUB BED PLANTING DETAIL**  
N.T.S.

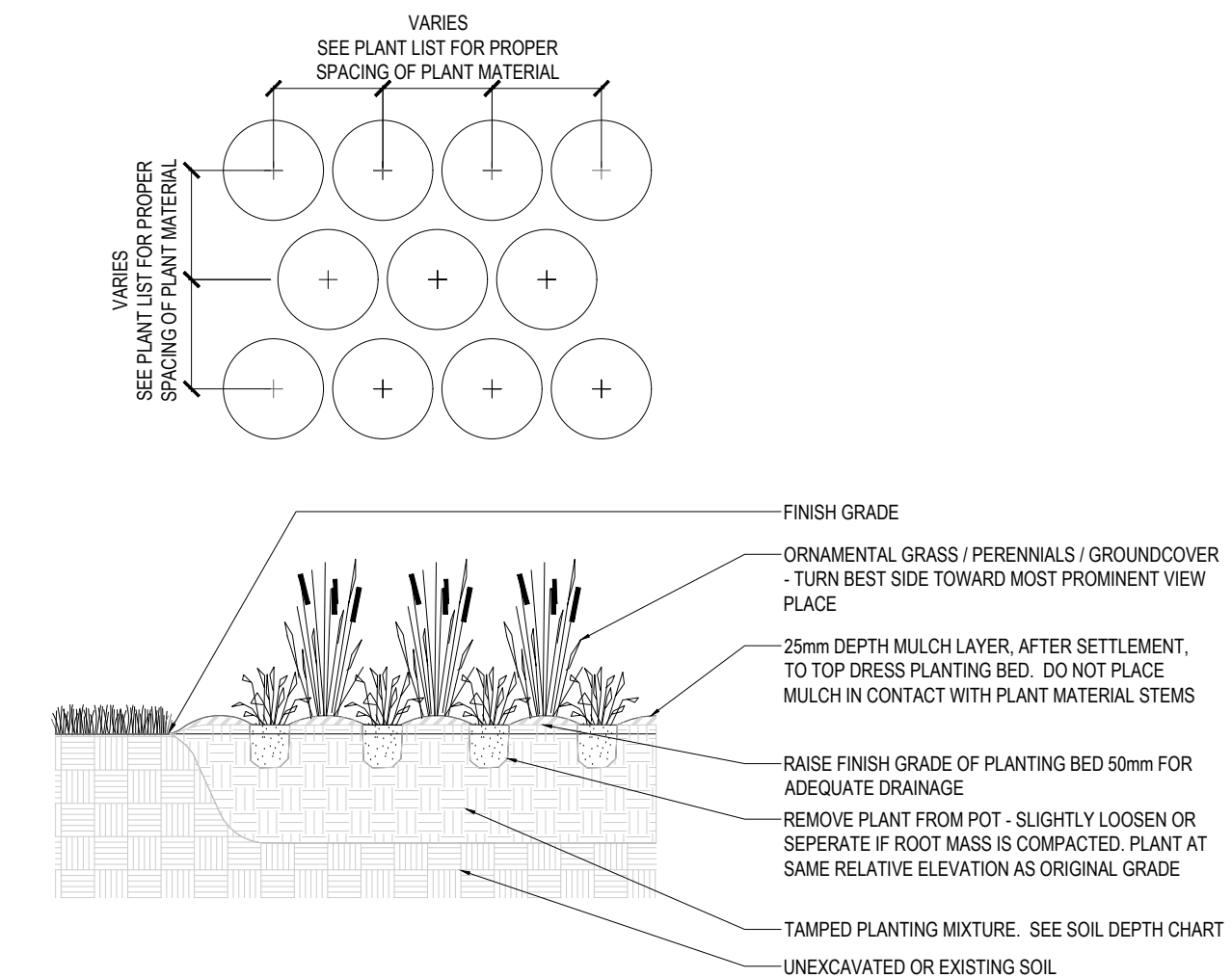

**7 GROUNDCOVER PLANTING DETAIL**  
N.T.S.

NOTE: THE CONTRACTOR IS TO SUPPLY TOPSOIL FILL MATERIAL TO THE DEPTHS INDICATED ON THE CHART BELOW.

LANDSCAPE AREAS	DEPTH IN mm
LAWN AREAS (SOD)	300
LAWN AREAS (SEED)	300
PLANTING BEDS - GRASSES, PERENNIALS AND GROUND COVER	300
PLANTING BEDS - MEDIUM AND SMALL SHRUBS	450
RAISED PLANTERS	600
SHADE AND ORNAMENTAL TREES	PER TREE INSTALLATION DETAIL

**8 SOIL DEPTH MINIMUMS**  
N.T.S.